



**MOTION CONTROL SYSTEMS**

# **GMH SERIES**

**STEPPING MOTOR DRIVES**

# **INSTRUCTION MANUAL**



**R.T.A. s.r.l.**

Via E. Mattei – Frazione DIVISA  
27020 MARCIGNAGO (PV)  
Tel. +39.0382.929.855 - Fax +39.0382.929.150  
Internet: <http://www.rta.it> - e-mail: [info@rta.it](mailto:info@rta.it)

**R.T.A.  
DEUTSCHLAND GmbH**







Bublitzer Straße, 34  
40599 DÜSSELDORF (Germany)  
Tel. +49.211.749.668.60-Fax +49.211.749.668.66  
Internet: <http://www.rta-deutschland.de>  
e-mail: [info@rta-deutschland.de](mailto:info@rta-deutschland.de)

**R.T.A. IBERICA  
MOTION CONTROL SYSTEMS S.L.**

C/Generalitat 22, 1º 3º  
08850 GAVA – BARCELONA (Spain)  
Tel. +34.936.388.805-Fax +34.936.334.595  
Internet: <http://www.rta-iberica.es>  
e-mail: [info@rta-iberica.es](mailto:info@rta-iberica.es)



# INDEX

1 -	NOTICES AND MANUAL STRUCTURE.....	3
2 -	  LIMITATIONS, HAZARDS AND CAUTIONS .....	4
3 -	GENERAL CHARACTERISTICS AND IDENTIFICATION.....	5
4 -	INPUT AND OUTPUT LOGIC SIGNALS.....	7
5 -	POWER INPUT AND OUTPUT .....	8
6 -	SETTING AND SIGNALING.....	10
7 -	DRIVE EXTERNAL CONNECTIONS .....	13
8 -	MOTHERBOARDS, POWER SUPPLIES AND RACKS .....	15
9 -	MOUNTING AN OPTIONAL CARD.....	19
10 -	  INSTALLATION AND ENVIRONMENT .....	20
11 -	LOGIC INTERFACING EXAMPLE .....	21
12 -	  EMC APPLICATION NOTES .....	22

**WARNING:** It is user **RESPONSIBILITY** to check that this manual refers to product model and version that will be used.

## Symbol meaning



The section marked with this symbol contains warnings regarding safety problems. If the directions indicated in these sections are not fulfilled, hazardous situations could arise.



The section marked with this symbol contains information regarding operations which are strictly forbidden.



## 1 -NOTICES AND MANUAL STRUCTURE

1.1 - This manual covers the following items:

- GMH series EUROCARD stepping motor drives in all their standard versions.
- Standard characteristics of special versions of GMH series stepping motor drives (see also chapter 1.2).
- Accessories for mounting and supplying: EURO RACKS, motherboards, PS series power supply in all their standard versions.

Also if some information about optional cards are given in this manual, you must ask for the specific optional cards manual, in case you are using one of these.

For models and versions identification see also chapter 3.

1.2 - For the purposes of this manual the terms used assume the meaning below described (fig. 1)

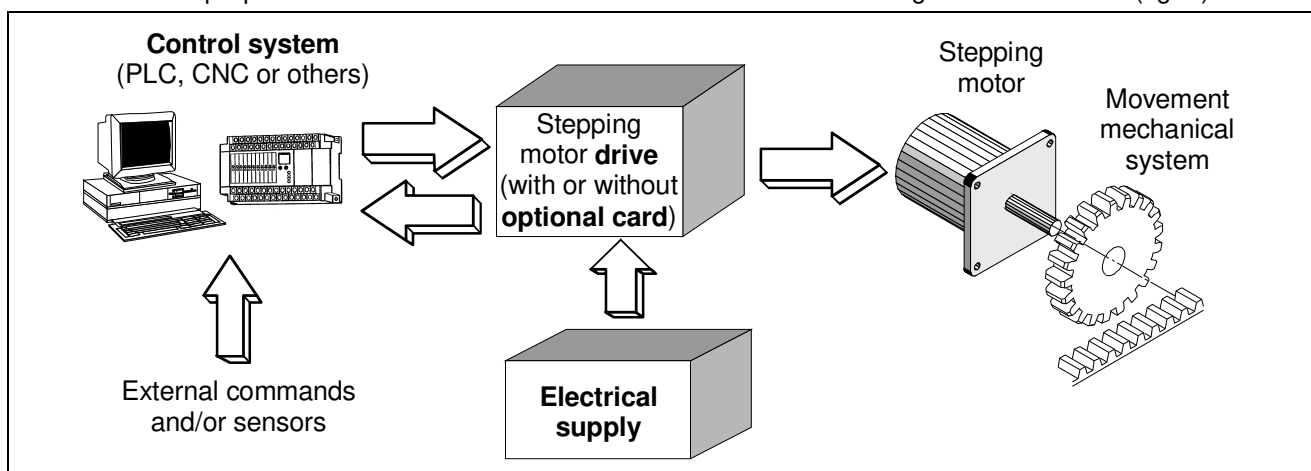

Fig. 1

- Drive: electronic part of electromechanical movement system, which receives some digital or analog input signal from an external control system and gives to the stepping motor the suitable phase excitation sequences, in order to obtain the mechanical movements required by the control system. The drive can also communicate its status to the control system through some logic signals. In this manual all drive considered are in EUROCARD format.
- Control system: part of the machine, which decides and controls all machine functions and gives to the drive all execution commands. It could be a numerical or programmable control, a personal computer or a specific control card. In the simplest machines it could also be a group of sensors and electromechanical switches.
- Electrical supply: all machine parts suitable to supply the drive in a correct way; usually rectifier, filter capacitor, transformer separating from the main, anti-interference filter and all switches and protection systems. Some of these components, like PS series power supply, can be supplied from R.T.A., others have to be assembled by user.
- Optional cards: electronic cards able to do some operations on logic or analog signals, which can be optionally mounted on the drive. They are located from the functional point of view between control system and drive. These cards usually perform some function required by some particular application. In any case they can never substitute the control system.
- Standard drives are all models (see chapter 3 for identification) whose characteristics comply completely with those described in this manual. Special versions are all models in which some characteristics differ from the description given in this manual. For these models, some part of the manual do not apply and, in these cases you must have the specific "variation sheet" which becomes an integral part of the manual itself.



- 1.3 - Products described in this manual (see list in chapter 1.1 and identification code in chapter 3) are CE marked and comply with the following directives:
- 1) Low Voltage (73/23/EEC and further modification)
  - 2) Electromagnetic Compatibility (89/336/EEC and further modification)
- 1.4 - Remember that, as stated in all directives, compliance exists only when a product is used in accordance with its destination and following manufacturer prescriptions. Thereby, all relevant indications about use, cautions, installation and limitations here described must be followed by user in order to stay within compliance limits: from this point of view, chapter 2, 10 and 12 are particularly important, but the entire content of this manual has to be carefully read and considered in order to obtain the information necessary for a correct use.
- 1.5 - Conformity declaration regarding above mentioned products, is kept by R.T.A. (as manufacturer residing in EEC country), together with technical construction file at authority disposal.
- 1.6 - This manual is conceived in a way to offer to the personnel involved in project and safety verification of a machine all information concerning characteristics, working conditions, application limits and cautions about GMH series stepping motor drives and related accessories. The knowledge of these information is essential for a correct project of machines, apparatus and systems in which the drives are used; it is strongly recommended not to start any operation with the drives before you have completely read and understood the content of this manual. Take into account that an incorrect use or installation, a wrong dimensioning of external safety elements related with the drive could bring to economical damages and also to hazards for human life.
- 1.7 - Consider the fact that these are products with a very wide range of possible applications in many different working and environment conditions. For this reason this manual can only fix limits and general rules but cannot take in consideration every single possible application condition. If you have problems to understand some part of this manual or to meet its indications with your specific application, do not hesitate to contact R.T.A. for further information. Take into account that R.T.A. has twenty years of experience in any kind of applications, which cannot be condensed in a manual but can always be at customer disposal.
- 1.8 - The terms "user and customer" often used in this manual always indicate a skilled person as defined in chapter 2.8.
- 1.9 - This manual is considered valid at the moment of the selling of the product. It cannot be considered inadequate as a consequence of product or manual changes or improvements after the selling. R.T.A. reserves the right of products and manual revisions without notice neither obligation of previous products and manuals revision.

## 2 - LIMITATIONS, HAZARDS AND CAUTIONS

- 2.1 - GMH series drives with all related options and accessories are suitable to drive two phases stepping motors with 4, 6 or 8 terminals with a phase-inductance range between 1 mH and 15 mH. Their use for different purposes is not allowed.
- 2.2 - It is also not allowed the use in any condition not complying with one or more specific limitations stated in this manual for electrical, mechanical and environmental quantity or characteristics.
- 2.3 - Both GMH series drives and racks are open frame sub-assemblies without protection enclosure (protection degree: IP 00). This means that they must be located inside a protective enclosure meeting requirements of standards applicable in the specific application in which they are used. Moreover the enclosure must provide a local environment suitable to the drives as indicated in chapter 10 and meet the requirements for electromagnetic compatibility indicated in chapter 12.
- 2.4 - Both drives and optional cards have some dip-switches located over the P.C.B. They perform some adaptations to the particular application (motor current, ramp profile, speed etc.). **All these settings have to be made with the machine switched off, before putting it in service.**
- 2.5 - Inside the GMH drives and PS series power supply, there are capacitors able to store a certain amount of electrical energy. As a consequence, in some cases, according with application conditions and supply dimensioning (see chapter 7), a dangerous voltage could remain on the drive after switching off for a time greater than 5 seconds.



- 2.6 - Some components mounted on PCB can reach high temperatures during normal working conditions (about 80°C heatsink; 120°C power resistors). Do not touch these components for some minutes, after switching off, in order to avoid scald hazard.
- 2.7 - After a failure due to connection mistakes or others, in the drives could arise a temporary hot spot. For this reason avoid absolutely to install in explosive or flammable environments. **Avoid also to install near easily flammable materials and components.**
- 2.8 - All products considered in this manual are sub-assemblies without a direct function, foreseen to be integrated in a more complex machine or installation by a professional assembler. Direct use of these products by a final user is not allowed. The professional assembler using this material has to be a skilled person, adequately qualified both in the generic field of electrical and electronic systems and in the specific field of stepping motor systems. It is exclusive responsibility of the designer of the complete machine or installation, in which this component is used, to take care of the safety and reliability of his project. It is forbidden to use this material in application covered from one or more EEC directives (for instance 89/336/EEC, 89/392/EEC, etc.), before the conformity to those directives has been declared. As far as regards 89/336/EEC directive, see also chap 12.
- 2.9 - Use for safety related functions is forbidden (EN 60204-1). Moreover, when the application arrangement is in such way that a drive fault or failure could generate a dangerous condition, external independent safety protection system must be provided in the machine.
- 2.10 - Logic low voltage input and output terminals are not electrically separated from internal power high voltage ( $V_{DCnom}$ ). Thereby, in case of drive failure, dangerous high voltage could appear at these terminals, also if this event is extremely rare. For this reason, from the point of view of evaluation of the machine safety during a single fault condition, the external control system, connected to these inputs, has to be considered potentially subjected to high voltage, unless an external separation is provided. If you need optical insulation at the control system side, ask to R.T.A. for a separate accessory card or choose an axis control card with optically insulated output.
- 2.11 - Both CURRENT OFF input signal (see chapter 4) and internal electronic functional protections (see chapter 6) switch off the drive output power by means of semiconductor devices. They cannot be used to interrupt power in emergency stop function or in any function involving personnel safety.

### 3 - GENERAL CHARACTERISTICS AND IDENTIFICATION

- 3.1 - GMH is the name of a bipolar *ministep* chopper drive series suitable to drive two phases stepping motors with 4, 6, 8 terminals.
- 3.2 - GMH drives are realized in EUROCARD format (100 × 160 mm.) with a form D - DIN 41612 - 32 pins input/output connector. Thereby they are conceived to be installed in a 3 unity EURO RACK, with a suitable motherboard and need an external DC supply. Power supply, motherboard and rack can be separately supplied on request from R.T.A. as accessories or directly assembled by user.
- 3.3 - General characteristics are as follows:
  - Chopper regulation of motor current.
  - Automatic current reduction at stand still.
  - Motor phase current setting by means of DIP-SWITCHES up to four possible values.
  - Operation modes, according to model, at 400, 500, 800, 1000, 1600, 2000, 3200 or 4000 steps/rev. selected with DIP-SWITCHES.
  - Possibility to switch off motor current with external logic signal (CURRENT OFF).
  - Possibility of multiplying four times step input signal.
  - Electronic protection against overload or short circuit at motor output
  - Electronic protection against variation of main voltage more than 25% in value.
  - High efficiency performance and high reliability of MOSFET power section.
  - Thermal protection against overheating.
  - Operation with a single external DC voltage source.



3.4 - Drive model identification is as follows:

## GMHxx.Y

where:

**xx** can be: **01, 02, 03, 05, 06, 07, 09** and identifies a standard model, differing for current value and available operation modes.

**.Y** is not present in standard models. If present **Y** can be a number or an alphanumeric character identifying a special version with some variations with respect to standard models.

Each sample is also identified with a serial number.

3.5 - Accessories for mounting and supplying the drives are the following:

- Power supplies: mod. **PS03, PS04, PS06**.
- Motherboard for power supplies: **PM2.Y**
- Motherboard for drives: mod **MM4.Y**

NOTE: The suffix ".Y" in motherboard identification code has the same meaning used for drives identification.

- 3 Unity empty EURO RACK 10.5, 12.5 and 19 inches width (only mechanical parts of the rack).
- 3 Unity EURO RACK 10.5, 12.5, 19 inches width pre-assembled by R.T.A. in some typical configurations, using the basis elements described in chapters 3.5.

3.6 - All basis elements (power supplies, motherboards and mechanical parts of racks) can be separately supplied if customer prefers to assembly by himself inside his structure. The only exception regards the power supplies which has to be used exclusively with its own motherboard. Obviously, in case of assembling by user, R.T.A. warranty and responsibility remains only on components supplied.

3.7 - Products described in chapter 3.5 are identified with the following code:

## RACK / X / RR / N / VT - YYY

where:

**X** Place or power supply:

- X = A: none
- X = B: present

**RR** Rack width:

- 10 = 10.5 inches
- 12 = 12.5 inches
- 19 = 19 inches

**N** Number of drive places in the rack (1 - 9)

**V** Number of fans mounted on the rack (0=NONE)

**T** Fan type (0=NONE; 1=110 V<sub>AC</sub> ; 2=220V<sub>AC</sub> ; 5=12 V<sub>DC</sub>; 6=24 V<sub>DC</sub>)

**YYY** Three alphanumeric characters used for codification of special versions. For standard versions is: YYY = 000

EXAMPLE: The code **RACK / B / 19 / 4 / 32 - 000** identifies a 19 inches width standard rack for drives with one motherboard for power supply, four motherboards for drives and three fans working at 220 V<sub>AC</sub>.

3.8 - For products described in chapters 3.5 and 3.7, the complete identification is accomplished with a serial number for each sample.



## 4 - INPUT AND OUTPUT LOGIC SIGNALS

4.1 - In the following table are listed input and output logic signals. In the column **DIN** is indicated the corresponding number of 32 pins Din I / O connector present on drive card. In the column **MOTH.** is indicated the corresponding number of the motherboard screw connector which is available only when the drive is mounted in a rack with a motherboard MM4 model (see fig. 5).

DIN	MOTH.	SIGNAL DESCRIPTION
6a	L6	<b>STEP INPUT:</b> Active transition: see chap. 6.5. Suggested duty-cycle 50%. Max frequency: 100 kHz with square wave signal supplied from a low impedance source (< 300 Ohm).
2c	L5	<b>DIRECTION INPUT:</b> With this signal HIGH (open) motor rotation direction is opposite to the one obtained with input LOW (short to GND). This signal has to be valid at least 50 µsec. before STEP signal and has to stay in this state for at least 50 µsec. after last STEP sent to the drive.
4a	L7	<b>CURRENT OFF INPUT:</b> When this signal is HIGH (open) drive is active. When is LOW (short to GND) drive is inhibited, thus motor current (and so holding torque) is turned to zero.
4c	L4	<b>STEP x 4:</b> When this input is active pulse sent to STEP INPUT are multiplied by four. For correct use see chap. 6.4 and chap. 6.5. This signal has to be valid at least 2 milliSec. before STEP signal and has to stay in this state for at least 2 milliSec. after last STEP sent to the drive.
10a	L2	<b>DRIVE FAULT OUTPUT:</b> When this output is LOW, drive is normally working; when is HIGH drive is in no-working state. Drive automatically goes in no-working state when some protection is active and automatically recovers when this protection resets. For use jumper DRF is needed.
12c	L10	<b>STEP OUT OUTPUT:</b> NORMALLY USED ONLY WITH OPTIONAL CARDS. See specific documentation. Output step sent to motor.
12a	L9	<b>AUX1:</b> ONLY WITH OPTIONAL CARDS: See specific documentation.
2a	L3	<b>AUX2:</b> ONLY WITH OPTIONAL CARDS: See specific documentation.
	L1	<b>LVDC+:</b> Positive terminal 12 V <sub>DC</sub> auxiliary output
30a-c 32a-c	L8 G1(rack)	<b>GND:</b> (Internally connected). Logic signals return (L8). Negative terminal of high voltage power supply (G1).
6c		<b>INTERNALLY CONNECTED: DO NOT USE.</b>

Table 1

4.2 - Use of output signals and some input signals is optional and depends on particular application; in any case GND terminal has always to be connected.

4.3 - Logic input characteristics:

- All input signals are CMOS standard, with internal 12 V<sub>DC</sub> or 5 V<sub>DC</sub> power supply, user selectable (see chap. 5).
- Voltage limits: **0 VOLT < Vin < 30 VOLT** (not depending by input voltage selection).
- With 12 V<sub>DC</sub> selection - **LOGIC LEVEL: LOW** = Vin < 4 VOLT --- **HIGH** = Vin > 8 VOLT.
- With 5 V<sub>DC</sub> selection - **LOGIC LEVEL: LOW** = Vin < 1.5 VOLT --- **HIGH** = Vin > 3.5 VOLT.

4.4 - Logic output characteristics:

- Max. voltage: 50 Volt - Max. output current: 25 mA - Max. dissipation: 300 mW.
- All output are open collector of a NPN transistor. Thereby they need an external load termination (like a resistor). One side of this load has to be connected to output terminal; the other side to the positive terminal of an external supply, whose negative terminal is connected to GND. In case of an inductive load (like a micro-relay), a recirculation diode must be connected across this load to avoid damages to internal output transistor (see fig. 12).

4.5 - Use of electro-mechanical device (i.e. relay) to drive inputs is not recommended. Delay and "bouncing", typical of this device, can give system malfunction.



4.6 - Inputs and outputs are **internally** realized as shown in fig. 2.

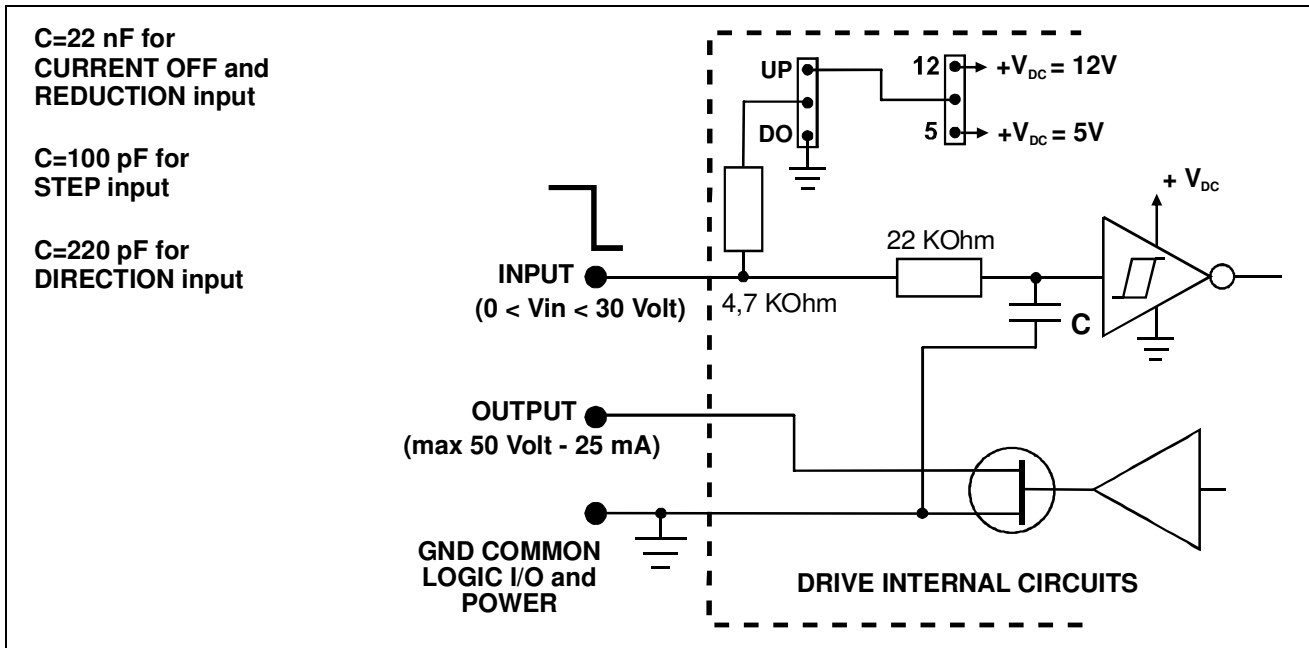

Fig. 2

## 5 - POWER INPUT AND OUTPUT

5.1 - Drive power inputs are the two connections to **V<sub>DC nom</sub>** coming from power supply. Drive power outputs are the four connections to stepping motor. They are listed in table 2.

DIN	MOTHERBOARD	DESCRIPTION
30a-c 32a-c	TP3	GND (- V <sub>DC nom</sub> ) Power supply negative pole
8a-c 10c	TP2	+ V <sub>DC nom</sub> Power supply positive pole
14a-c 16a-c	P4	Motor winding terminal A
18a-c 20a-c	P3	Motor winding terminal A-
22a-c 24a-c	P1	Motor winding terminal B
26a-c 28a-c	P2	Motor winding terminal B-
	P10	Shield of motor shielded cable has to be connected to this point. Internally connected to TP3, G1 and 30a-c, 32a-c.

Table 2

- 5.2 - The indication of more than one terminal for the same function in the DIN 41612 connector means that they are internally interconnected. In these cases, they have to be put in parallel also in the external circuit made by user, in order to obtain a correct current partition among the contacts of the connector itself. This prescription is very important because a current overload in a single contact could cause overheating, damage and also fire.
- 5.3 - The terminal indicated as GND (30a-c 32a-c on DIN connector, TP3 and L8 on the motherboard, G1 on the rack) is the common return both of logic signals and high voltage power supply. About this terminal the following considerations apply.
- 5.3.1- Theoretically the drives could work without any earth connection in a complete floating system but, in this case, some possible internal insulation failures, will not be detected by protection system (electronic protection, internal fuses or external protection components), causing potentially hazardous situations like dangerous voltage present on rack body or drive body (heatsink or panel if mounted) or dangerous voltage present at logic input/output or others. Moreover you will have much more problems in satisfying EMI requirements (see also chapter 12).





5.3.2- The recommended solution is the connection of GND terminal to earth (PE terminal). This connection has to be made or through 30a-c, 32a-c if you are using a drive card, or through G1 if you are using a rack; do not use L8 terminal, which is suitable only for logic signals return. If you do this, take care that no other earth connections are made in the power circuit (transformer winding connections and motor connections) and consider carefully the paths of other earth connections (if they exist) in the control system connected with drive logic input/output, in order to avoid or reduce earth loop problems.

5.4 - Table 3 shows the characteristics of power input and output.

		GMH 01/05	GMH 02/06	GMH 03/07	GMH 09
<b>V<sub>DC min</sub></b>	(VOLT)	43	43	43	76
<b>V<sub>DC nom</sub></b>	(VOLT)	from 55 to 85	from 55 to 85	from 55 to 85	from 100 to 180
<b>V<sub>AC nom</sub></b>	(VOLT)	from 41 to 61	from 41 to 61	from 41 to 61	from 72 to 135
<b>V<sub>DC max</sub></b>	(VOLT)	102	102	102	240
<b>V<sub>DC abs</sub></b>	(VOLT)	125	125	125	275
<b>V<sub>DC ripple</sub></b>	%V <sub>DC nom</sub>	7	7	7	7
<b>I<sub>NP min</sub></b>	(AMP)	1.7	3.4	6.7	6.7
<b>I<sub>NP max</sub></b>	(AMP)	3	6	12	12
<b>I<sub>NP Step</sub></b>	(AMP)	0.4	0.9	1.7	1.7
<b>I<sub>NP lim 25</sub></b>	(AMP)	3	6	8	N.A.
<b>I<sub>NP lim 40</sub></b>	(AMP)	3	4	7	N.A.
<b>DIMENSIONS</b>	(mm)	100 × 168 × 30	100 × 168 × 30	100 × 168 × 42	100 × 168 × 51

**Table 3**

N.A. = not applicable for the model

5.5 - Definition of terms used in table 3:

- V<sub>DC min, max</sub>** Minimum and maximum supply voltage for drive operation; under and over this voltage automatic protections will inhibit drive operation.
- V<sub>DC nom</sub>** Nominal value of DC voltage supply (range) at which the drive can operate without stabilized supply.
- V<sub>AC nom</sub>** RMS value of alternating voltage at the transformer secondary winding corresponding to V<sub>DC nom</sub>.
- V<sub>DC abs</sub>** Absolute maximum DC supply voltage which can be tolerated from the drive for no more than one minute.
- V<sub>DC ripple</sub>** Maximum percentage of peak to peak ripple voltage respect to mean value of DC nominal voltage.
- I<sub>NP</sub>** Indicates nominal phase current, which flows in each motor winding, measurable with motor turning at low speed. The drive is equipped with automatic current reduction with motor at stand still. Phase current is calibrated at final test moment and can be set from the customer, choosing among eight different values, by means of DIP-SWITCHES.
- I<sub>NP min, max</sub>** Minimum and maximum nominal phase current value which can be set by user using DIP-SWITCHES.
- I<sub>NP Step</sub>** Spacing of the four possible current values, set with DIP-SWITCHES.
- I<sub>NP lim 25</sub>** Maximum value of nominal current at which the drive can operate without forced cooling with a local ambient temperature of 25 °C and in the following conditions:
  - Operating mode** Half step with equalization active
  - Duty cycle** 50%
  - Supply voltage** 75 V<sub>DC</sub>
- I<sub>NP lim 40</sub>** Same as I<sub>NP lim 25</sub> but with a local ambient temperature of 40 °C.



**Note:** Nominal currents indicated for **I<sub>NP</sub> lim 25** and **I<sub>NP</sub> lim 40** have to be considered as an indication and are not an absolute limit but take into account a final stage temperature able to grant a reasonable drive MTBF (see also chapter 10.6).

## 6 - SETTING AND SIGNALING

6.1 - GMH series drives are general purpose products which can be used to drive many different motor models in different kind of applications. For this reason they have a six positions DIP-SWITCH suitable to adapt drive characteristics to the specific motor and/or application. **The setting of this switch has to be made by customer before putting in service the drive. Do not forget to do these settings: Wrong setting could get application errors and also motor damages and hazards.** Led signalling drive status are also present.

6.2 - Fig. 3 shows the position of DIP-SWITCHES, bridges and signalling LEDs in GMH drives:

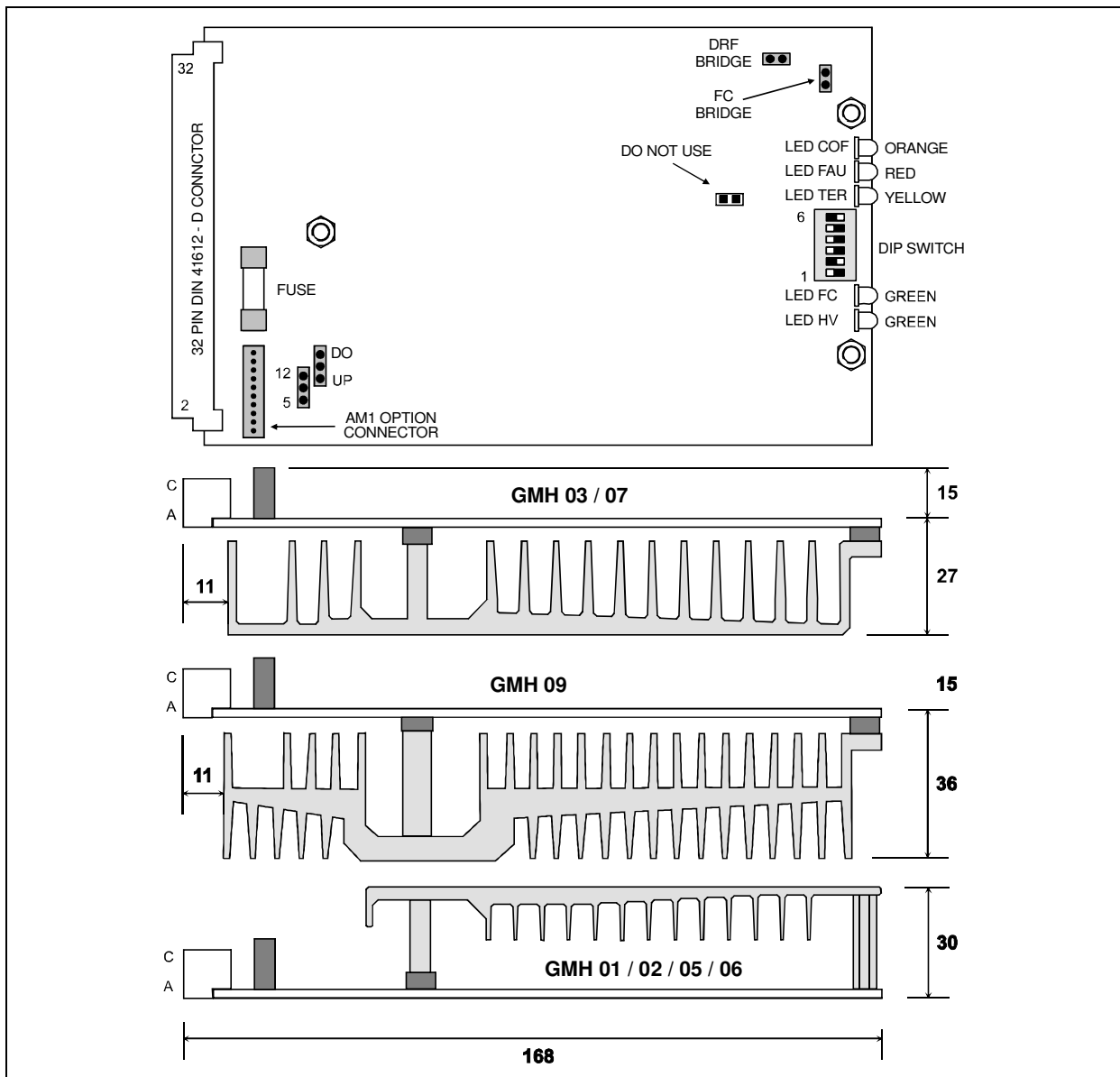

**Fig. 3 ALL MEASURES IN MILLIMETERS – MOUNTING HOLES Ø 4 mm. (For use consult RTA)**

6.3 - DIP-SWITCHES setting. The table 4 shows the settings of dips 1, 2 for all model of GMH drive, as a function of motor nominal current suitable to a specific application.



NOMINAL CURRENT $I_{NP}$ in Ampere (dip-switches 1, 2)				
dip 1	dip 2	GMH 01 / 05	GMH 02 / 06	GMH 03 / 07 / 09
ON	ON	1.7	3.4	6.7
ON	OFF	2.1	4.3	8.6
OFF	ON	2.6	5.1	10.3
OFF	OFF	3	6	12

**Table 4**

6.4 - The table **5a** (for GMH 01/02/03) and **5b** (for GMH 05/06/07/09) shows the settings of dipo 3, 4, 5, 6 as a function of required operation mode.

EQUALIZATION (dip-switches 3, 4)				OPERATION MODE (dip-switches 5, 6)		
dip 3	dip 4	Medium Speed	Low Speed	dip 5	dip 6	STEPS / REV.
ON	ON	EXCLUDED	EXCLUDED	ON	ON	4000 ×
ON	OFF	EXCLUDED	ACTIVE	ON	OFF	2000 ×
OFF	ON	ACTIVE	EXCLUDED	OFF	ON	1000
OFF	OFF	ACTIVE	ACTIVE	OFF	OFF	500

**Table 5a – GMH 01/02/03**

EQUALIZATION (dip-switches 3)		OPERATION MODE (dip-switches 4, 5, 6)			
dip 3		dip 5	dip 6	dip 4 STEPS/REV.	
ON	EXCLUDED			▶ ON	OFF
OFF	ACTIVE				
		ON	ON	4000 ×	3200 ×
		ON	OFF	2000 ×	1600 ×
		OFF	ON	1000	800
		OFF	OFF	500	400

**Table 5b – GMH 05/06/07/09**

▶ = default factory setting

× = in this operation mode STEP × 4 INPUT is active

6.5 - BRIDGES (JUMPERS) function. Regarding DO/UP and 12/5, bridge must be in one of two possible positions. Use of these bridges in a different way can give system malfunction.

▶ FC ON	AUTOMATIC CURRENT REDUCTION excluded
▶ FC OFF	AUTOMATIC CURRENT REDUCTION active
▶ DRF ON	DRIVE FAULT OUTPUT present at DIN 10a
▶ DRF OFF	DRIVE FAULT OUTPUT not working
▶ DO/UP in DO	Inputs terminated by PULL DOWN (input PNP) STEP transition: LOW to HIGH – STEP × 4 active HIGH
▶ DO/UP in UP	Inputs terminated by PULL UP (input NPN) STEP transition: HIGH to LOW – STEP × 4 active LOW
▶ 12/5 in 12	Input range 12 Volt
▶ 12/5 in 5	Input range 5 Volt

**Table 6**



6.6 - The following tables 7a and 7b show the meaning of the signaling LEDs existing on the drive.

LED		SIGNALING
HV	ON	supply voltage inside correct operating range.
	OFF	drive not supplied or supply voltage out of the correct operating values (in the second case you have also LED FAU ON).
FC	ON	full current at drive outputs. (normally without jumper FC drive is at full current when INPUT STEP is driven and CURRENT REDUCTION INPUT not driven).
	OFF	reduced current at drive outputs (65% of $I_{NP}$ ).
TER	ON	drive placed in no-working state by thermal protection (in this case LED FAU is on).
	OFF	Heat-sink temperature in working range.
FAU	ON	drive placed in no-working state by one of the following protection: a - Thermal protection if LED TER on b - Max. or Min supply voltage if LED HV off. c - Short circuit or wrong motor connection if LED HV on and LED TER off.
	OFF	drive in working state if LED HV on.
COF	ON	CURRENT-OFF driven (drive disabled from an external command).
	OFF	drive active.

Table 7a

LED					DRIVE CONDITION
HV	FC	TER	FAU	COF	
OFF	OFF	OFF	OFF	OFF	Drive not supplied or fuse broken
OFF		OFF	ON		Wrong supply voltage
OFF		OFF	OFF	ON	Wrong configuration (*)
OFF	ON	OFF	OFF		Wrong configuration (*)
ON		ON	ON		Thermal protection
ON		OFF	ON		Short circuit at motor output or drive broken
ON	OFF	OFF	OFF	OFF	Drive working at reduced current
ON	ON	OFF	OFF	OFF	Drive working at full current
ON		OFF	OFF	ON	Zero motor current due to ext. command
ON		ON	OFF		Wrong configuration (*)

Table 7b

(\*) The LED configuration shown is impossible. This means that there is some failure in the drive or in associated external circuits.

**NOTE:** OFF = LED switched off

ON = LED switched on

All protections are self-resetting, when the intervention causes disappear.



## 7 - DRIVE EXTERNAL CONNECTIONS

In fig. 4 an example of the drive external cabling is indicated, showing the way to realize the power supply which has to be made by user; these indications apply only when user buys the drive alone without rack, motherboard and power supply produced by R.T.A.: in the case you have a complete rack with power supply, refer to chapter 8.

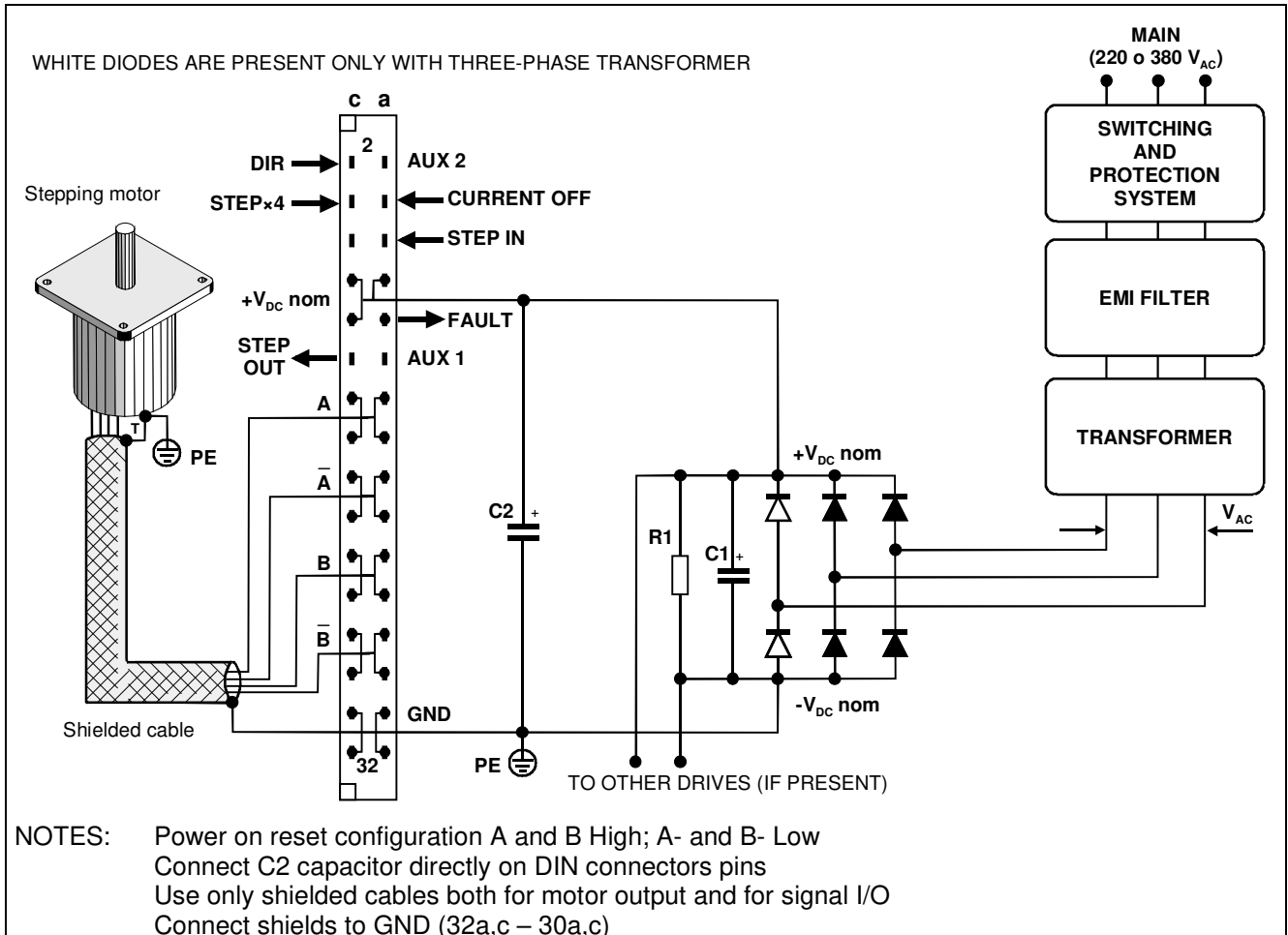

Fig. 4

7.1 - Dimensioning power for transformer, bridge rectifier, filter capacitor and related external components. The basis to calculate this power is the total power required from the drive and motor. It is the sum of the following three terms:

- Mechanical power delivered to load: mainly depending on application characteristics like friction, inertia, efficiency of mechanical transmission etc.
- Motor losses: mainly depending on motor type, drive voltage, speed and duty-cycle. Very often it is hard to do an exact forecast of mechanical characteristics or of duty-cycle; in these cases a safety over-dimensioning of the supply elements proportional to the uncertainty of the data is recommended. Anyhow, in case of doubt, consult R.T.A. or authorized personnel submitting all data of the specific application.
- Drive losses: mainly depending on drive model, current setting and duty-cycle; according with these parameter these losses can approximately vary between 15 and 60 watt (the first value is referred to GMH 01/05 at minimum current; the second value is referred to GMH 09 at maximum).



- 7.2 - In the schematic diagram of fig. 4 it is shown the possibility to use a single-phase group or, in alternative, a three-phase group. The choice between the two solutions depends on technical and economical considerations hard to summarize. Generally speaking a three-phase group is strongly recommended when the total required power overcomes one of these two limits: 500 - 600 Watt mean power and 700 Watt peak power. Please consider this only as a rough indication.
- 7.3 - C1 capacitor value has to be calculated in a way to get a ripple voltage level below the one indicated in table 3; in any case, also if the ripple level value is fulfilled, this component can never have a capacitance below the one given by the following formula:

$$\sqrt{N} \times C_{min}$$

in which:

$$N = \text{number of drives connected to the same power supply}$$
$$C_{min} = 3300 \mu\text{F for GMH 01/05, GMH 02/06 and GMH 03/07}$$
$$C_{min} = 1500 \mu\text{F for GMH 09}$$

- 7.4 - C2 capacitor purpose is to compensate the effects of the inductance of the connection cable between capacitor C1 and drive. When this length is very short (less than 10 cm), C2 capacitor could be avoided. In general, for cabling until 2 mt long a value of 220  $\mu\text{F}$  for capacitor C2 is normally enough. As far as regards the above mentioned cabling, a twisted pair arrangement is recommended.
- 7.5 - Capacitors C1 and C2 must have a working voltage at least equal to the working voltage chosen for the drive and must have a relatively low impedance at high frequency (use types suitable for switching applications).
- 7.6 - R1 resistor purpose is to discharge C1 and C2 when the system is switched off, avoiding the risk they remain indefinitely charged at high voltage. In some cases, due to high capacitance value, it could be difficult to obtain a discharge time enough short (less than 5 sec. to go below 60 Volt). Remember that, in these cases, you must put a clear label in your installation in order to warn the operators of the residual voltages risk.
- 7.7 - Transformer must fulfill to the following three requirements:
- Supply through a secondary the correct voltage depending on drive model in accordance with  $V_{AC}$  values shown in table 3. These  $V_{AC}$  values are intended as measured at secondary terminals in no load condition and with primary voltage at its nominal value. Maximum voltage drop at full power load must be less than 5%.
  - Grant the separation between the drive circuits and the main. **Remember that connection of drive circuits with the main is strictly forbidden.**
  - Grant the separation between the drive circuits and all other circuits of the same machine. **This means that the transformer secondary dedicated to drives has to be used exclusively for drives.**
- 7.8 - F1 fuses must perform the protection of supply group. They have to be slow acting fuses (T or TT type), whose nominal current has to be chosen in accordance with supply dimensioning power. In order to clarify protection coordination problems take into account that the function of these F1 fuses is to protect supply circuit up to drive power input terminals. Protection of circuits after this point is ensured by electronic protections of the drive and, in case of drive failure, by another fuse (fast acting type, shown in fig. 3) located inside the drive and directly connected to positive terminal of power supply. F1 fuses could be also replaced with other protection systems (like for instance circuit-breakers) able to perform the function above described.
- 7.9 - The cross-sectional area of conductors used in the supply circuit must be chosen according with dimensioning power (see 7.1). The cross-sectional area of the four shielded conductors between motor and drive must be chosen in accordance with nominal current which has been set in the drive; if the cabling length from motor to drive is particularly long (more than 20 mt) a certain over dimensioning of cross-sectional area, respect to standard values required by nominal current, is recommended in order to reduce total losses and voltage drop along the cables, which could affect motor performances.



## 8 - MOTHERBOARDS, POWER SUPPLIES AND RACKS

- 8.1 - RTA can supply, in order to house GMH series drives, pre-assembled, 3 Units EUROPA racks of 10.5", 12.5" and 19". The racks are fitted with a Power Supply and a variable number of places for drives upon customer's request. A complete rack is composed from following parts (fig. 7):
- Support mechanics.
  - One or more motherboards, MM4 type to be used with drives.
  - One motherboard PM2 to be used with Power Supplies type PS.
  - One Power Supply type PS03, PS04, or PS06.
  - One or more cooling fans.
- 8.2 - Partial set-ups, like for example a rack with no Power Supply with only places for drives (when customer has available his own external supply) or with no cooling fans (when installation ambient conditions and dissipated powers in specific application allow such solution) can be delivered. When the user has at disposal his own rack, containing other equipment, even single components can be supplied, like:
- rack chassis
  - motherboards for drives, MM4 type
  - Power Supply with respective motherboard, PM2 type
- 8.3 - The power transformer is not included in the rack. For its dimensioning see chapter 7 and chapter 8.6. In case of systems with more than one rack, a transformer for every single rack is needed.
- 8.4 - Motherboard MM4 is a printed circuit board, which is mounted on the rear rails of a 3 units rack. The motherboard holds, on the face towards rack front, a DIN 41612 form D connector (where drive is inserted) and, on the back face, two screw-type terminals (P and L in fig. 5) connected to corresponding pins of the DIN connector (see column MOTH. in tables 1 and 2). Screw-type terminal P is used for connections with motor, where screw-type terminal L is used for connections with control logic. The three terminal points (TP1, TP2, TP3), where the bus-bars (connected to the Power Supply motherboard PM2) are soldered, are used to carry  $V_{DC\ nom}$  supply voltage and a 12 Volts source for auxiliary purposes.

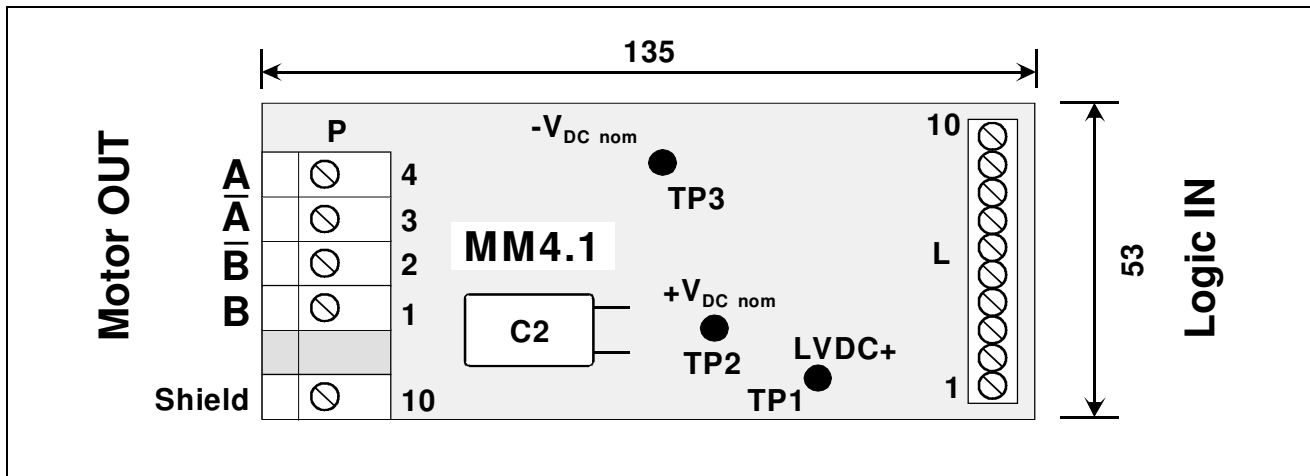
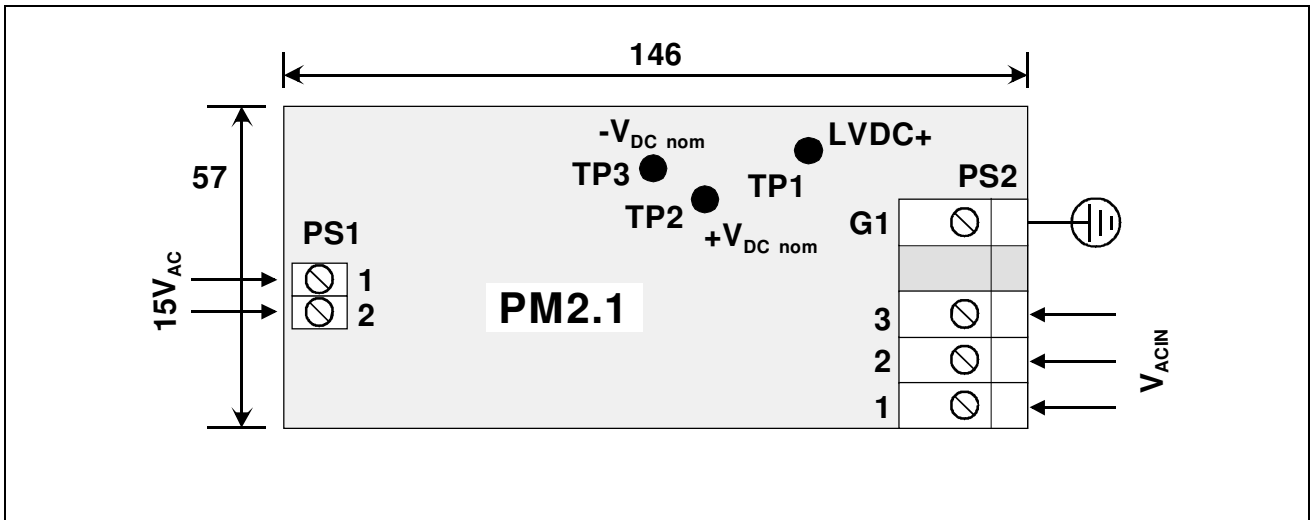

Fig. 5 - DRIVE MOTHERBOARD REAR VIEW (FROM SCREW CONNECTOR SIDE)

- 8.5 - Motherboard PM2 is a printed circuit board, which is mounted on the rear rails of a 3 units rack. The motherboard holds, on the face towards rack front, a DIN 41612 form D connector (where Power Supply PS03, PS04 or PS06 is inserted) and, on the back face, two screw-type terminals (PS1 and PS2 in fig. 6). PS2 is used for the connection of the secondary winding of the power transformer, where PS1 is used for the connection of secondary 15  $V_{AC}$  winding, when customer needs a 12  $V_{DC}$  voltage for auxiliary purposes. This auxiliary voltage is not necessary for drives operation and therefore connection to PS1 have to be done only if they are needed from the user. The three terminal points (TP1, TP2, TP3), where the bus-bars are soldered, are used to carry the  $V_{DC\ nom}$  supply voltage and the 12  $V_{DC}$  to drives motherboards.



**Fig. 6 - SUPPLY MOTHERBOARD REAR VIEW (FROM SCREW CONNECTOR SIDE)**

8.6 - Common characteristics of Power Supplies are the following:

8.6.1- Realization on single Eurocard (100 × 160 mm) containing:

- A principal Power Supply realized by means of a three-phase rectifier bridge, complete with filter capacitors and protection fuses at the three-phase alternating voltage input. The characteristics are specified at point 8.7.
- An auxiliary Power Supply realized by means of a single-phase rectifier bridge, complete with filter capacitors, protection fuses at the single-phase alternating voltage input and electronic regulator at the output. The characteristics of this auxiliary Power Supply (equal for all the models) are the following:
  - Alternating input voltage: 15 V<sub>AC</sub>
  - Direct output voltage: 12 V<sub>DC</sub>
  - Maximum output current: 0.5 Amp

8.6.2- Output on DIN 41612-form D connector, to be directly plugged in motherboard PM2 type. The Power Supplies have to be used only with this type of motherboard. RTA doesn't take on any responsibility if the Power Supply is put in operation without using motherboard PM2 type.

8.7 - In table 8 the characteristics of power section of Power Supplies are summarized

SUPPLY MODEL	PS03	PS04	PS06
V <sub>ACin</sub> (Volt)	41 - 61	69 - 100	110 - 135
V <sub>DCnom</sub> (Volt)	58 - 85	95 - 139	152 - 187
P <sub>OM</sub> (Watt)	550	600	700
P <sub>TRM</sub> (VA)	750	750	1.000
P <sub>OT</sub> (Watt)	900	1.200	1.700
P <sub>TRT</sub> (VA)	1.000	1.400	2.000

**Table 8**

The meaning of terms used in table 8 is the following:

**V<sub>ACin</sub> (Volt):** Nominal alternating input voltage, at which the Power Supply can be used. (Line voltage in case of a three-phase system).

**V<sub>DCnom</sub> (Volt):** Direct voltages, available at no-load at the output of the Power Supply, corresponding to V<sub>ACin</sub> input voltages.

**P<sub>OM</sub> (Watt):** Maximum output available power when using single-phase transformer.

**P<sub>TRM</sub> (VA):** Needed power value of the single-phase transformer in order to obtain P<sub>OM</sub>.

**P<sub>OT</sub> (Watt):** Maximum output available power when using three-phase transformer.

**P<sub>TRT</sub> (VA):** Needed power value of the three-phase transformer in order to obtain P<sub>OT</sub>.





**NOTE 1:** Indicated values for  $P_{OT}$  and  $P_{OM}$  are valid under forced ventilation conditions of Power Supply card (Air speed > 0.3 mt/sec). Under natural ventilation conditions these values have to be halved.

**NOTE 2:** Voltage values indicated in table 8 are valid only for Power Supplies. If voltage limits of drives connected to Power Supply are more restricted, these last have to be kept as valid.

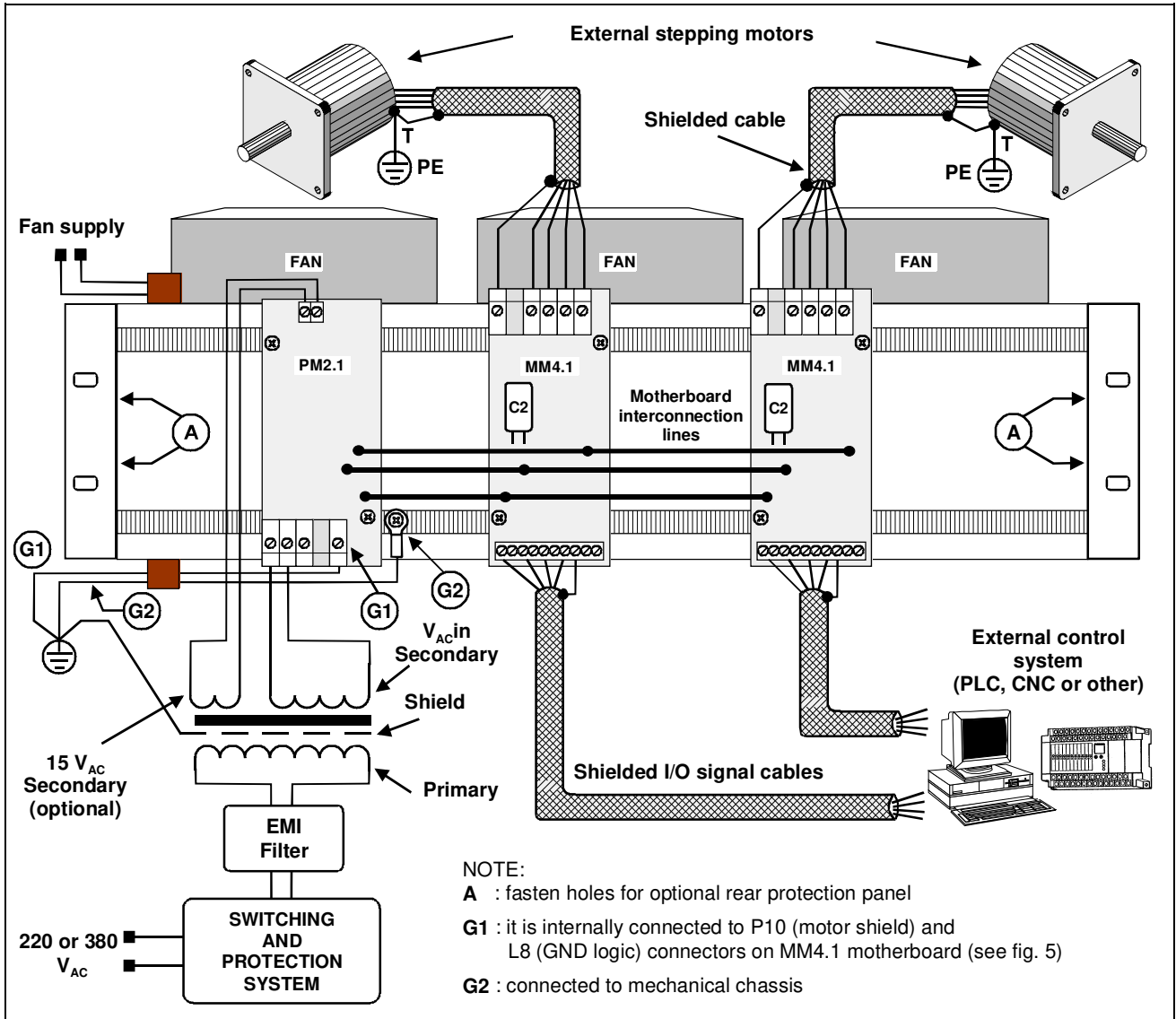

**Fig. 7 RACK REAR VIEW**

8.8 - In Fig. 7 are shown connection diagrams of a complete rack set-up (one Power Supply, two drives and three fans) with external elements (motors, control system and transformer). As far as regards input and output logic signals, refer to chapter 4 and 5. In order to simplify the drawings, in the figure a single phase transformer is shown. When you use a three-phase transformer, obviously, you have to use also the third screw connector of PM2 motherboard; in this case the transformer secondary has to be triangle connected. With rack configurations without power supply, the PM2 motherboard is not present and thereby the user must make the necessary connections between the supply lines of MM4 motherboards and its own external supply. Dimensioning criteria are the same indicated in the chapter 7.



8.9 - The table 9 indicates the maximum number of drives which can be located in a rack according to:

- type of rack
- presence or not of power supply
- presence or not of an optional card mounted on the drive

TABLE 9		RACK 10.5"		RACK 12.5"		RACK 19"	
		YES SUPPLY	NO SUPPLY	YES SUPPLY	NO SUPPLY	YES SUPPLY	NO SUPPLY
GMH 05 and 06	YES OPT.	2	3	4	5	6	6
	NO OPT.	2	3	4	5	6	7
GMH 07	YES OPT.	2	3	4	5	5	7
	NO OPT.	2	3	4	5	6	7
GMH 09	YES OPT.	2	3	3	4	5	6
	NO OPT.	2	3	3	4	5	6

8.10 - Maximum rack dimension in millimeters are listed below. Height and depth are comprehensive of fans and motherboard.

TABLE 10	RACK 10.5"	RACK 12.5"	RACK 19"
WIDTH (mm.)	270	377	483
HEIGHT (mm.)	185	185	185
DEPTH (mm.)	210	210	210

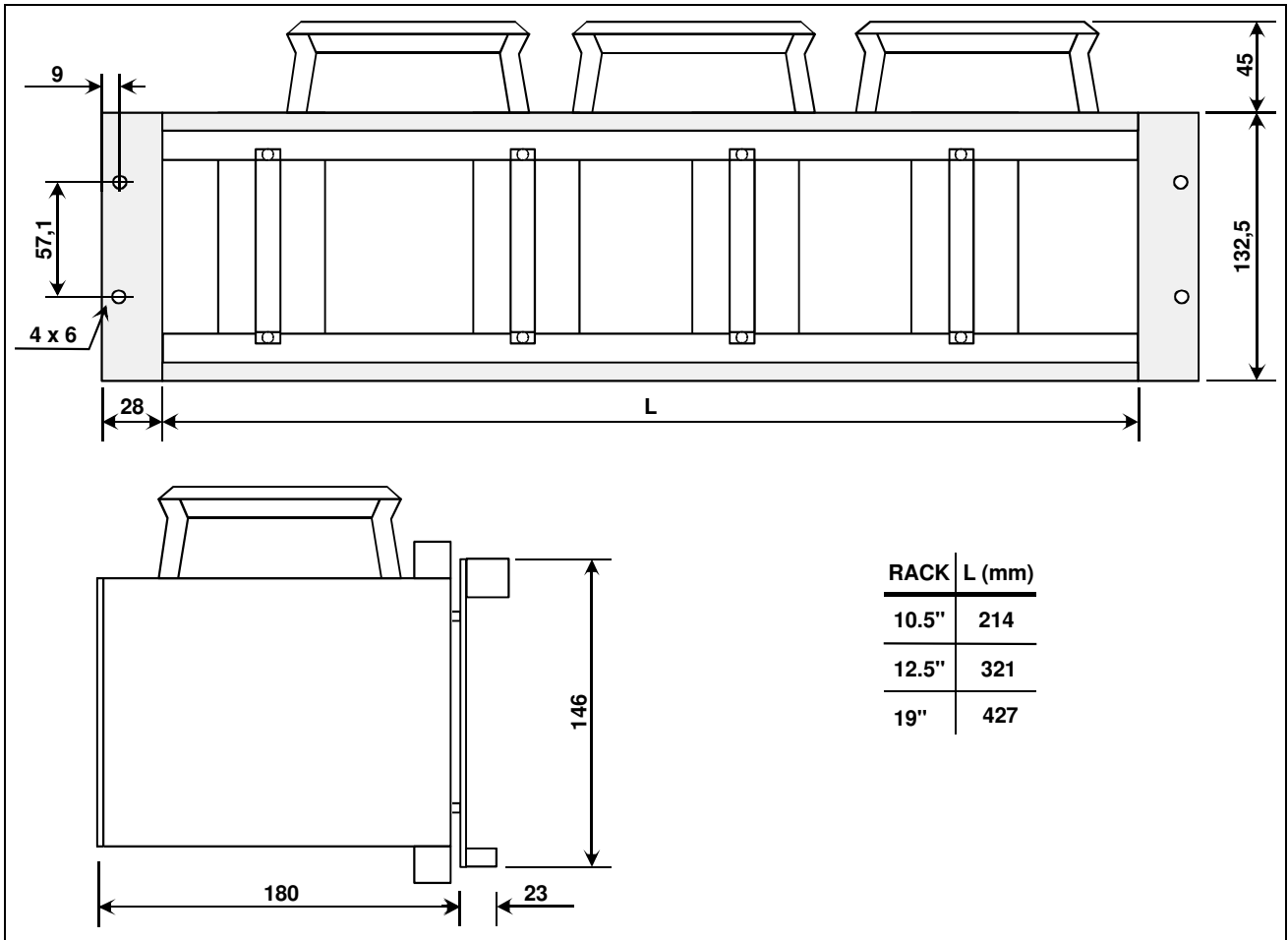

Fig. 8 STANDARD RTA RACK DRAWING. ALL MEASURES IN MILLIMETERS.



## 9 - MOUNTING AN OPTIONAL CARD

- 9.1 - Mounting an optional card on GMH drives: on GMH drive some optional card able to perform special function suitable to particular applications can be mounted. In this chapter are given mounting instructions for these cards. This information does not exhaust the subject. Ask to R.T.A. for the specific optional card manual for a complete instruction, in case of use.
- 9.2 - Mechanical mounting: use the three columns present on the upper side of the printed circuit board. As far as regards the way to execute the mounting, follow what indicated in fig. 9.

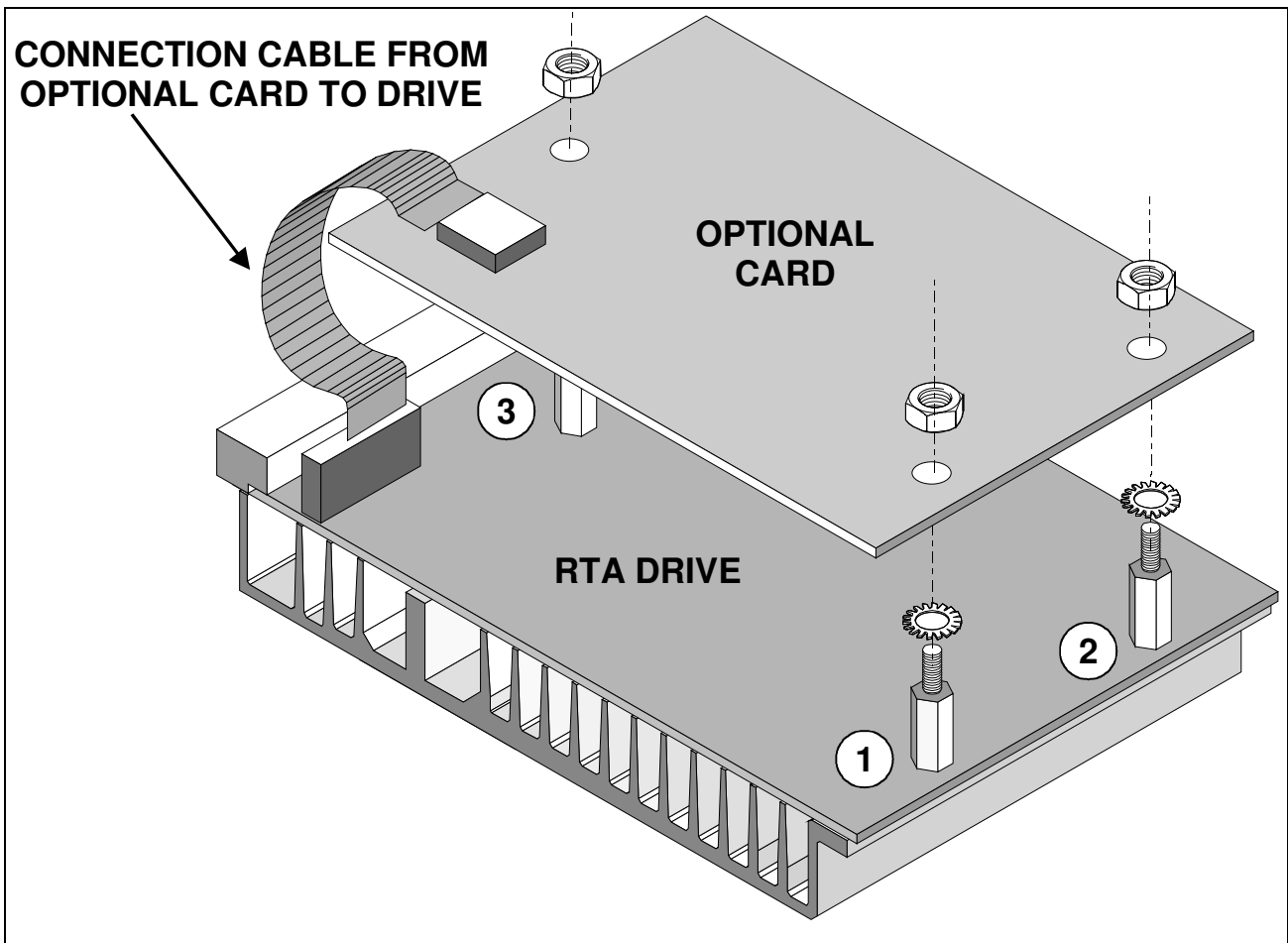

Fig. 9

- 9.3 - After mechanical mounting, insert the connection cable and check carefully that the distance between any component mounted on drive and any point of optional card is more than 2 mm.
- NOTE** - Columns 1 and 2 are used not only for mechanical blocking but also for electrical connection of the supply voltage (12 V<sub>DC</sub> - 25 mA) coming from drive for optional card. To avoid problems or failures, do not use those columns for other purpose, different from what here described.
- 9.4 - Take care of the fact that, in some cases, when an optional card is mounted, meaning and action of some input or output logic signals could change. Check specific documentation.



## 10 - INSTALLATION AND ENVIRONMENT

All products considered in this manual have the following common characteristics.

10.1 - Protection degree IP 00 (EN 60529). It is user responsibility to provide a protection enclosure able to eliminate contact hazard, to provide suitable environment for drive, to avoid radiation of electromagnetic interferences (see chapter 12) and, in general, to meet the standards regarding the specific application in which the products are used.

10.2 - Direct connection with the main is not allowed. Transformer separation is mandatory.

10.3 - Installation and work environment. Installation is allowed in a micro-environment with:

- **Environment conditions class 3K3** (IEC 721-3-3): that implies, among other things, a working temperature from +5°C to +40°C and relative humidity from 5% to 85% non condensing.
- **Pollution degree 2** (IEC 664-1): that implies, among other things, that installation in environments in which **explosive and/or flammable and/or chemically aggressive and/or electrically conductive gas, vapor or dust could be present is strictly forbidden.**
- **Mechanical conditions class 3M1** (IEC 721-3-3)

If the environment, in which the machine is used, does not satisfy this condition, suitable conditioning systems have to be provided for the enclosure.

10.4 - Storage environment in original enclosure:

- Temperature: from -25°C to +55°C; Relative humidity: from 5% to 95%.
- Environment conditions class 1K3 (IEC 721-3-1); Pollution degree 2.

10.5 - Low voltage input and output terminals are **not** electrically separated from internal power high voltage. Those terminals are **not** impedance protected. Thereby, in case of drive failure, dangerous high voltage could appear at these terminals, also if this event is extremely rare. For this reason, from the point of view of evaluation of the machine safety during a single fault condition, the external control system, connected to these inputs, has to be considered potentially subjected to high voltage, unless an external separation is provided.

10.6 - The drives generate some amount of heat (see chap. 7.1 - c). Take care of this in considering the total amount of heat generated in the enclosure in which the drives are located. In order to make easier air circulation in the drive, install it in a way that P.C.B. lies in a vertical plane with the shortest side in vertical position and the LED in the upper side; moreover keep free some space below and above the drive.

10.7 - According to model, working ambient temperature and operating conditions (mainly nominal current setting and duty cycle) forced cooling can be necessary. As a first indication about this problem, consider the limits shown in table 3 but take into account that many other application and environment parameters could change the situation. The most sure method to evaluate if this need exists or not is to measure temperature of the drive heat-sink during a test made in the most unfavourable working conditions. If this temperature is greater than 70°C and you wish to obtain a reasonable long life from drive, you need a forced cooling. As most unfavourable working conditions, you have to assume:

- Heaviest duty cycle among those that the machine can perform.
- Working voltage at the upper limit of expected tolerances.
- Local ambient temperature equal to the maximum value expected during the real working conditions of machine.

The measurement has to be made after thermal steady state conditions are reached, in the warmer point of heat-sink.

10.8 - When an optional card is mounted on drive, some input and output could change name and or function and thus some section of this manual could no more apply. For more details see optional card instruction manual.

10.9 - Maximum operating altitude 2000 meters.



## 11 - LOGIC INTERFACING EXAMPLE

In this chapter are shown some interfacing techniques. They have to be considered only as an example. The best way to interface the drive with the control system can be chosen only with a complete knowledge of the control system and application needs.

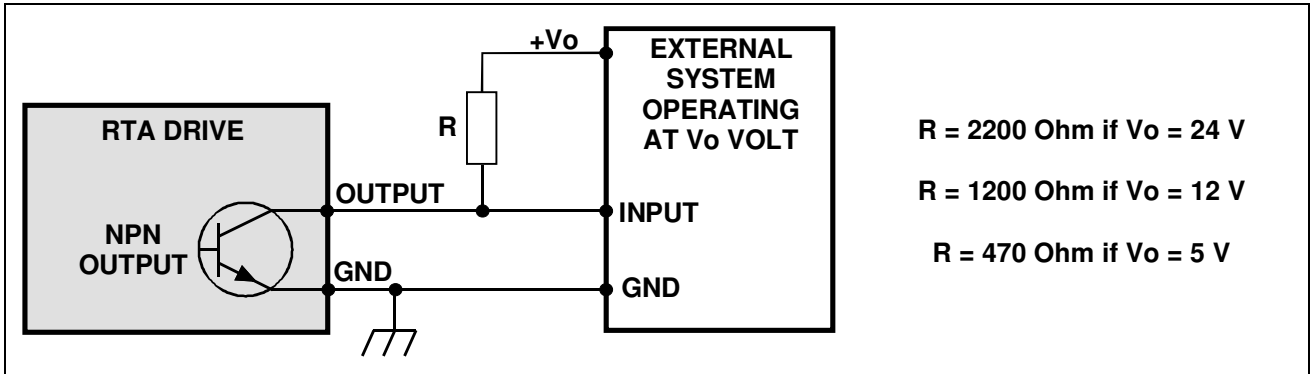

**Fig. 10:** Interfacing a GMH logic output and an input of a control system operating at  $V_o$  voltage.

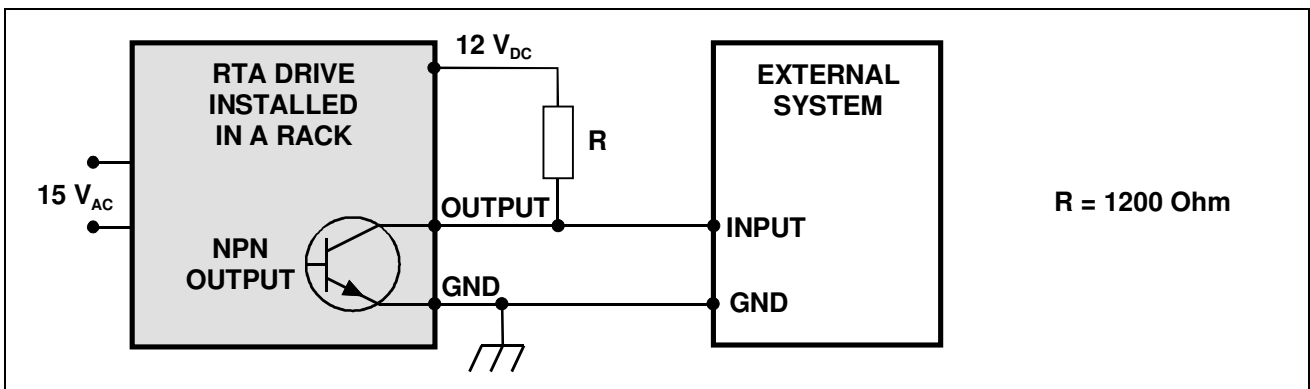

**Fig. 11:** Interfacing a GMH logic output and an external control system operating at 12 Volt, using auxiliary supply available on PS series power supply. Only when the drive is mounted in a rack with power supply. Remember that the auxiliary supply is available only if PS low voltage input is connected to a 15 V<sub>AC</sub>.

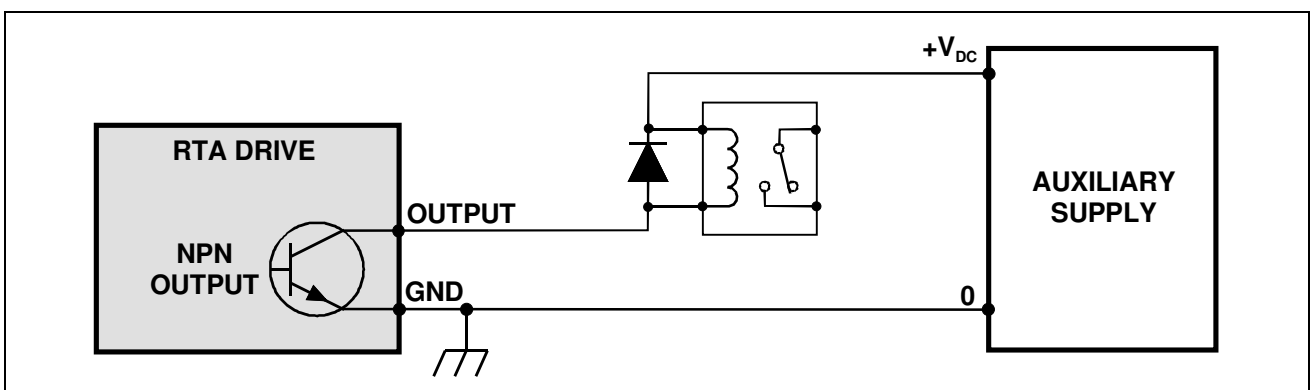

**Fig. 12:** Driving a micro-relay by means of a GMH logic output. Do not forget the recirculation diode across the relay. The auxiliary supply indicated in the figure could be both an external supply made by user and the auxiliary supply present in PS series power supply.

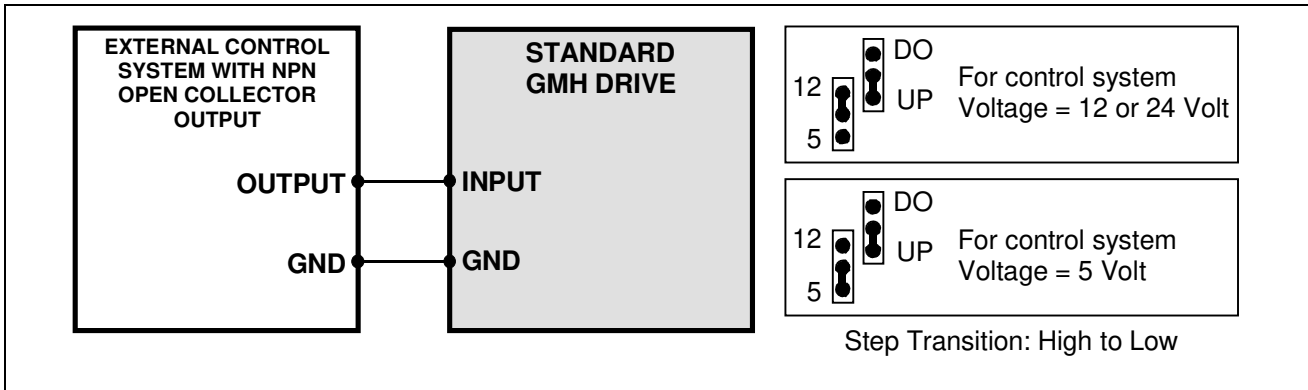

**Fig. 13:** Driving a GMH logic input from a control system with a NPN open collector output.

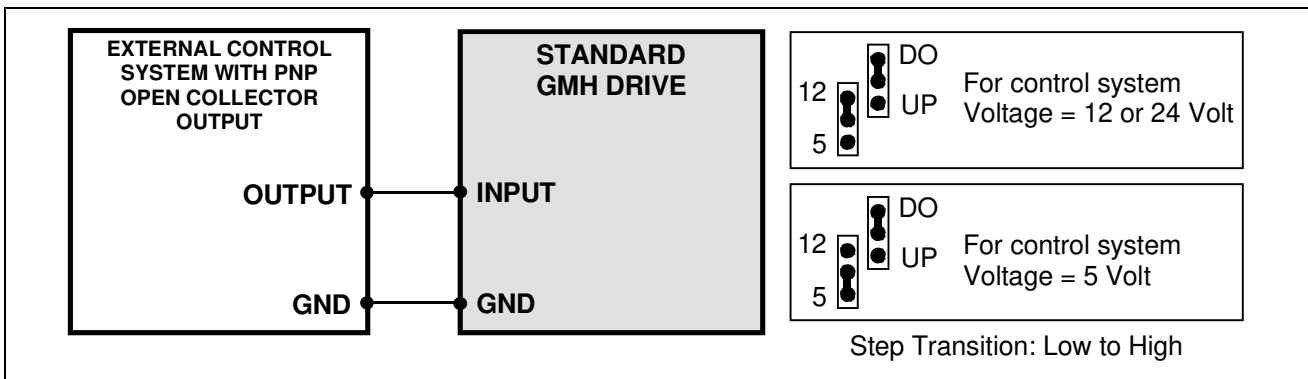

**Fig. 14:** Driving a GMH logic input from a control system with a PNP open collector output.

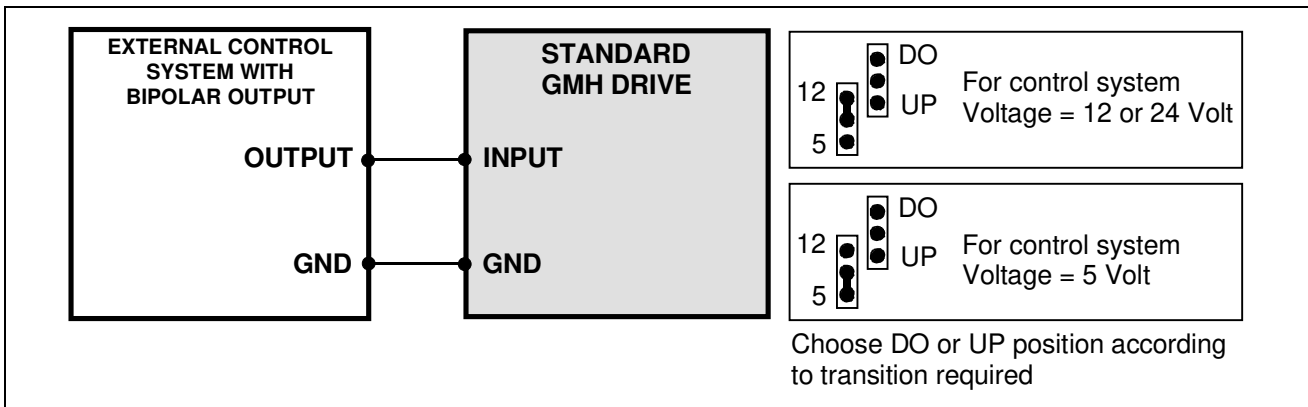

**Fig. 15:** Interfacing between an external control system with bipolar output.

## 12 - EMC APPLICATION NOTES

- 12.1 - Electromagnetic interferences and immunity (89/336/EEC directive)
- 12.2 - These products are sub-assemblies without a direct function, foreseen to be integrated in a more complex machine or installation by a professional assembler. It is forbidden the direct use of this product by a final user.
  - 12.2.1- GMH series drives are BDM (Basic Drive Module) conceived for restricted distribution (EN 61800-3 Ch. 3.2). This means that R.T.A. has the responsibility to verify the products compatibility in some typical way of use in order to give correct installation directions. In any cases, it is responsibility of the professional assembler, who installs this product, to verify the compatibility of the complete machine or system.
- 12.3 - The set consisting of drive, motor, transformer and all related cablings are source of electromagnetic interferences. Measures must be taken from assembler of installation in order to shield and/or reduce these interferences at a level allowed by the specific standards regarding the particular field



in which the machine operates. Consider that the strongest sources of radiated interferences are the four cables connecting the motor with the drive and some traces on drive PCB; the conducted interferences can arrive to the main through power supply. The most effective measures able to reduce these interferences are the following:

- Locate drives, rack, transformer and related cables inside the same enclosure, which has to shield the electromagnetic fields, in the range of frequencies normally considered in the most common standards.
- Use only shielded cable for the connection between motor and drive (a single cable with four wires inside the same shield). The shield of this cable has to be connected directly to drive GND terminals (30a-c; 32a-c of DIN connector) at the drive side and to motor chassis at the motor side. Keep as short as possible the terminal parts of this cable out of the shield. Use, if possible, a cable without intermediate interruption; if you need an intermediate interruption use a circular metal can connector in order to reduce the shield discontinuity.
- Connect GND terminals (30a-c; 32a-c of DIN connector) to earth and to enclosure metal chassis with a line having a high frequency impedance possibly low.
- Normally the motor body is connected to machine chassis through mounting flange and screws. If the machine chassis is not a single unity and the motor is mounted in a part of machine chassis separated from the one in which there is the enclosure containing the drive, take care to ensure a good earth connection among different parts of chassis.
- Very often in the same shielded enclosure in which there is the drive, also other circuits are present: in this case consider carefully locations of all internal cabling in order to avoid or reduce electromagnetic couplings among different circuits; take into account the fact that, if inside the enclosure there is a coupling between the drive circuit and an other passive circuit, electromagnetic interference could go outside the enclosure through external cabling of this passive circuit.
- Use a supply transformer with a metal shield between primary and secondary winding and connect this shield to earth.
- Interpose a filter between the transformer primary and the main. Filter characteristics in a specific installation depend on following factors:
  - Strictness degree of the specific standard regarding the machine on which drive is used. (type of machine, class of installation etc.).
  - Power level of application (mainly drive model, voltage and current setting, number of drives).
  - Presence of other filtering systems in the general electrical machine installation.

In any case, following filter types are recommended:

- 1) - CORCOM VDK series for single-phase power supply
- 2) - CORCOM FCD10 series for three-phase power supply

Different models inside these series differ for current rating; thereby choose the specific model according to power level of your installation.

Other filter types can be used provided the attenuation characteristics are the same. Location of filter and of their related cabling are very important: take care that no electromagnetic coupling exists between circuits up the filter and circuits down the filter; if such coupling is present, the effectiveness of filter could be strongly reduced (see also fig. 17).

12.3.1- Considering drive logic input signals immunity from external noise present in environment in which they are most often used (industrial equipment, installation class A or B), take in account following normal procedures, suggested from the classical techniques of relatively fast signals treatment:

- Use shielded cables, with shield connected to common logic (30a,c 32a,c DIN connector or L8 terminal in case of motherboard).
- When cables length exceeds 5-6 meters, use "buffer" type driving signals instead of "open collector" type.
- Keep signal cables separate from power cables. In particular keep signal cables separate from motor output cables and from other circuits cables which could generate E.M. noise.
- Verify carefully logic level compatibility when interfacing drive with control system.

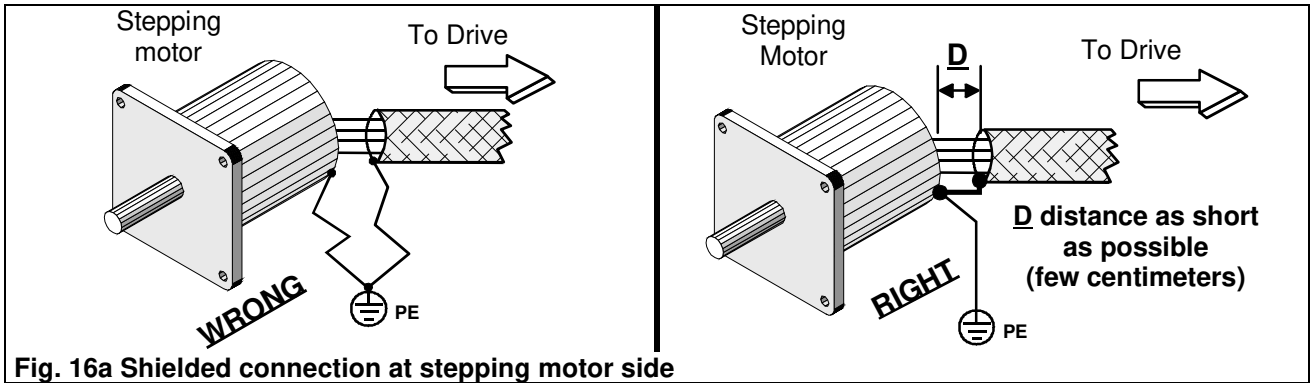

Fig. 16a Shielded connection at stepping motor side

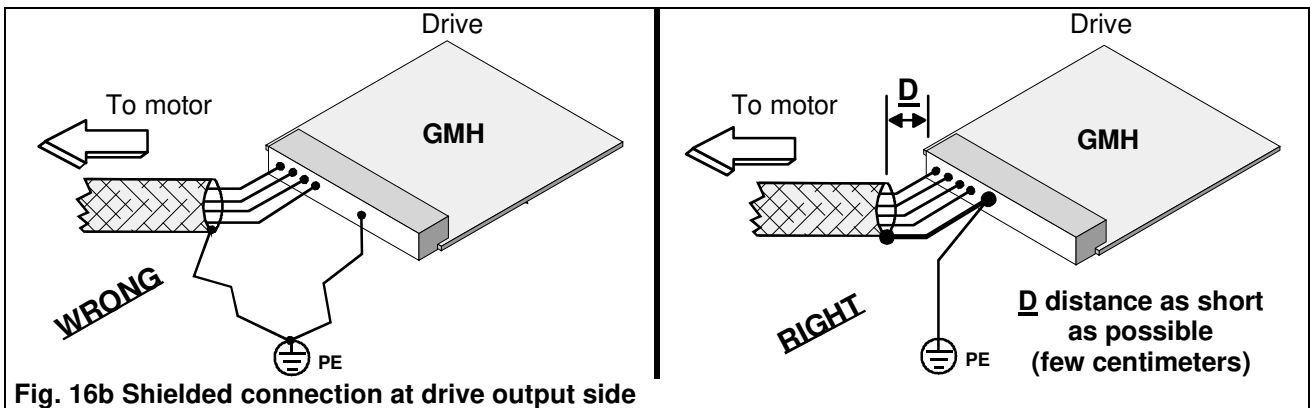

Fig. 16b Shielded connection at drive output side

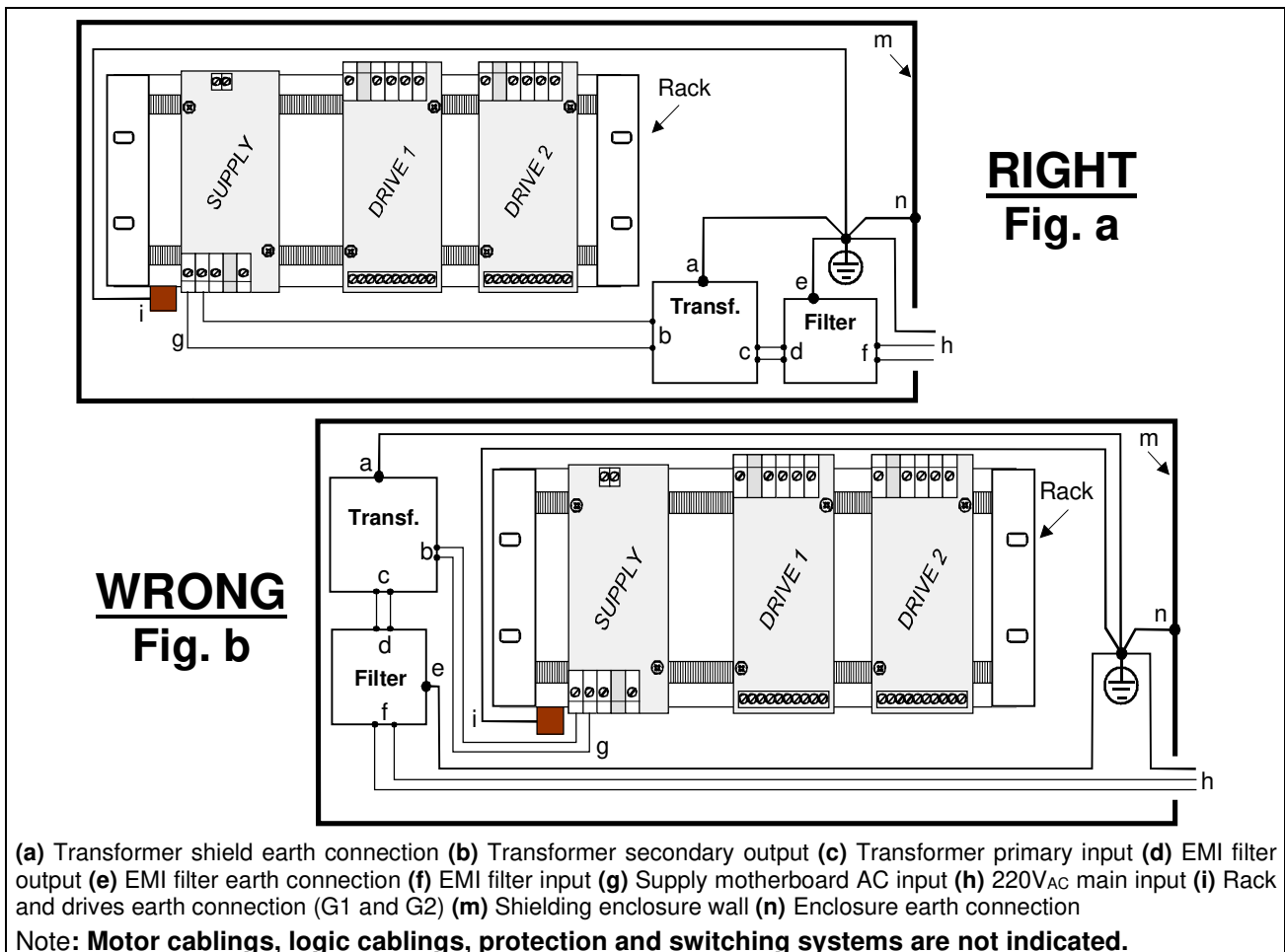

Fig. 17 - Example of filter, transformer and related cabling positioning inside the enclosure





- 12.3.2- Figures 16 and 17 represent examples of right and wrong way to do motor, drive and supply connections from the point of view of electromagnetic interference. In particular, fig. 17 stress the point that the position, inside the enclosure of filter, transformer and related cabling are very important. In fig. 17-b is represented a situation in which the filter is located in a part of the enclosure far from the 220 V<sub>AC</sub> input point: the long cabling existing between this input and filter input "collect" electromagnetic field present inside the enclosure and could be source of conducted interference, on which the filter is ineffective. In fig. 17-a the same cabling is very short and this problem is avoided.
- 12.3.3- A correct accomplishment of these procedures constitutes an essential starting point, in order to realize an installation, which complies with the requirements of 89/336/EEC directive. The effective compliance with specific standards covering the particular application, in which this drive is used, will have in any case to be proved in the complete installation, because the effectiveness of suggested actions depends also on machine topology and on their correct fulfilment. Tests performed from our company simulating typical installations and following above mentioned indications, show that it is possible to stay within the limits of the EN 55011 standard (Group 1, both for classes A and B).
- 12.3.4- In some cases, due to the characteristics of particular installations, conflicts between ground connections necessary for shielding purposes and ground connections necessary for safety reasons could arise. Remember that, in such cases, prescriptions regarding safety take priority, but remember also that, in the great majority of cases it is possible to find a solution meeting both prescriptions.