



HGD 02/05 SERIES STEPPING MOTOR DRIVES

WARNING: It is user RESPONSIBILITY to check that this manual refers to product model and version that will be used.

1) GENERAL CHARACTERISTICS

		HGD 02	HGD 05
V _{DC} nom	(V)	from 24 to 75	from 24 to 75
Tolerance V _{DC} nom	(%)	15	15
I _{NF} min	(A)	0.75	2.25
I _{NF} max	(A)	2	6
Dimensions	(mm)	70 × 70 × 27	
Operating temperature		from + 5°C to + 45°C (see point 7)	

Terms used in table definition

- **V_{DC} nom** Nominal value of DC voltage supply (range) at which the drive can operate without stabilized supply.
- **Tolerance** Maximum percent allowable variation of V_{DC} nom. values.
- **I_{NF}** Nominal phase current (peak value) which flow in each motor winding, measurable with motor turning at low speed. This current can be selected by user among six different values using **LB** inputs.
- **I_{NF} min and max** Minimum and maximum value of nominal phase current setting (selected using **LB** inputs).

2) LOGIC INPUT AND DRIVE FAULT OUTPUT (LA, see fig. 1, 2 and 3)

All inputs and outputs are standard CMOS with 5 V_{DC} power supply

- LA (1) **INTERNAL GND:** Logic inputs and outputs common. It can be used to connect the shield of logic signal cable if that is mandatory or useful depending on type of control system.
- LA (2) **CURRENT OFF INPUT:** When this signal is HIGH drive is active. When it is LOW drive is inhibited, thus motor current (and so holding torque) is turned to zero.
- LA (3) **CURRENT REDUCTION INPUT:** When this input is LOW current is reduced to 50% the value set.
- LA (4) **DIRECTION INPUT:** With this signal HIGH motor rotation direction is opposite to the one obtained with input LOW. This signal has to be valid at least 50 μsec. before STEP signal and has to stay in this state for at least 50 μsec. after last step sent to the drive.
- LA (5) **STEP INPUT:** Step is performed on HIGH-LOW transition of this signal. Suggested duty-cycle 50%. Max. frequency = 200 KHz with square wave signal supplied from a low impedance source (< 300 Ohm), 0-5 Volt.
- LA (6) **DRIVER FAULT OUTPUT:** When this output is SHORTED, drive is normally working; when it is OPEN drive is in no-working state. Drive automatically goes in no-working state when some protection is active and automatically recovers when the protection resets.

3) POWER INPUTS AND OUTPUTS (P, see fig. 2, 3)

- P (1) Power supply positive pole (+ V_{DC}).
- P (2) Power supply negative pole (- V_{DC}).
- P (3) Motor winding terminal **B-**
- P (4) Motor winding terminal **B**
- P (5) Motor winding terminal **A-**
- P (6) Motor winding terminal **A**
- P (7) Connection point for shield of motor shielded cable.

4) MAIN SETTINGS (LB, see fig. 2, 3)

Main setting is done by means of logic input on LB connector, according to motor type and working condition. On these inputs, instead of those on LA connector, there are no filters. These inputs are directly connected to CMOS inputs, and so they must be driven by CMOS output or by micro-switch. Connection has to be made directly on the PCB that house the drive with connection length as short as possible.

LB (1) GND logic signals.

NOMINAL CURRENT I_{NF} in Ampere				
LB (2)	LB (3)	LB (4)	HGD 02	HGD 05
LOW	LOW	LOW	0.75	2.25
LOW	LOW	HIGH	0.75	2.25
LOW	HIGH	LOW	0.75	2.25
LOW	HIGH	HIGH	1.0	3.05
HIGH	LOW	LOW	1.25	3.70
HIGH	LOW	HIGH	1.50	4.55
HIGH	HIGH	LOW	1.80	5.40
HIGH	HIGH	HIGH	2.0	6.0

OPERATION MODE – STEPS FOR REV.		
LB (6)	LB (7)	HGD 02/05
LOW	LOW	800
LOW	HIGH	400
HIGH	LOW	3200
HIGH	HIGH	1600

CURRENT PROFILE MANAGEMENT			
LB (5)	JUMPER M	TYPE	CHARACTERISTIC
LOW	OPEN	A	STANDARD
LOW	SHORTED	B	ENHANCED MOTOR SMOOTHNESS
HIGH	OPEN	C	ENHANCED MOTOR TORQUE
HIGH	SHORTED	D	MIXED

NOTE: Default factory setting of M jumper: SHORTED

APPLICATION NOTES:

- A type is a standard current profile.
- B type current profile performs higher motor movement smoothness with lower acoustical noise and vibrations. Smoothing effect of B type depends on resolution setting: the more resolution is low, the more smoothing is effective.
- C type current profile performs higher motor torque.

FULL / REDUCTED CURRENT SELECTION	
LB (8)	
LOW	Automatic current reduction excluded
HIGH	Automatic current reduction active

NOTE: HIGH = open; LOW = shorted to GND.

WARNING: With Automatic current reduction excluded motor or drive can over-heat.

5) DRIVE STATUS BY LED

LED HV green:	ON	= supply voltage value in working range.
	OFF	= no supply voltage or supply voltage out of working range
⁶⁾ LED FAU red:	ON	= drive set in no working state by one of the following protection: a – Thermal protection, if LED TER is ON b - Max or Min voltage when LED HV is OFF c - Short circuit or wrong connection at motor output when LED HV is ON
	OFF	= drive active provided that LED HV is ON
LED TER yellow:	ON	= drive set in no working state by thermal protection.
	OFF	= drive active provided that LED HV is ON.

6) ELECTRO-MAGNETIC INTERFERENCE

Drive and all related cabling are source of E.M. interference (conducted and radiated). In order to comply to directive 2004/108/CE and related standards installation has to be done in strict accordance to schematics in fig 2 and following indications:

- Locate drives, power supply, transformer and related cables inside the same enclosure, which has to be hermetic to electromagnetic fields.
- Interpose a filter between the transformer primary and the main (CORCOM VDK series). Locate the filter near the entrance of main supply in the enclosure.
- Use only shielded cable (outside the enclosure) for connecting motor and drive.
- Connection made to Protective Earth terminal (PE), shown in fig.2, must be short and have the lowest possible inductance.
- Use a supply transformer with a metal shield between primary and secondary winding and connect this shield to earth.

7) FORCED COOLING

According to operating conditions (ambient temperature, current setting, duty-cycle) forced cooling can be necessary. The most sure method to evaluate if this need exists or not is to measure temperature of the drive heatsink; if this temperature is greater than 65 - 70 °C in the most unfavourable working conditions, you need a forced cooling to obtain a reasonable long life from drive.

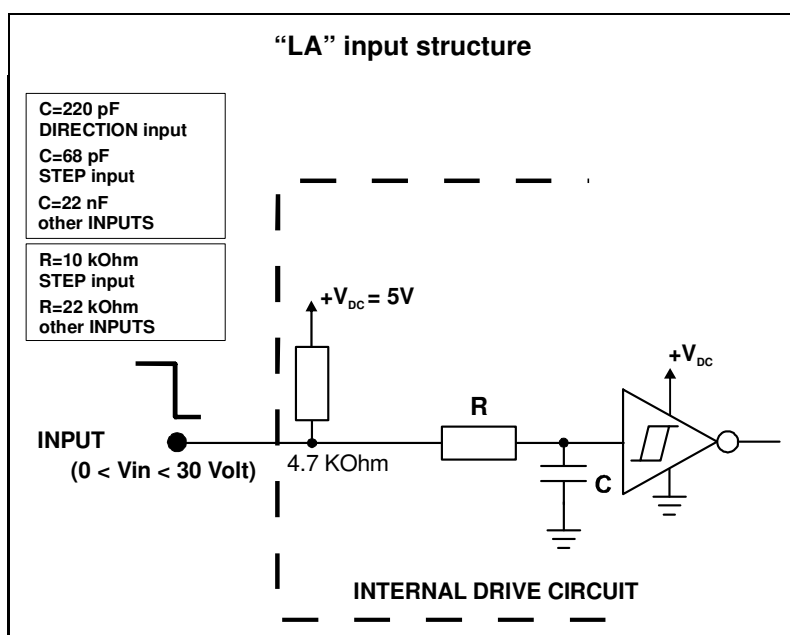

Fig. 1 a

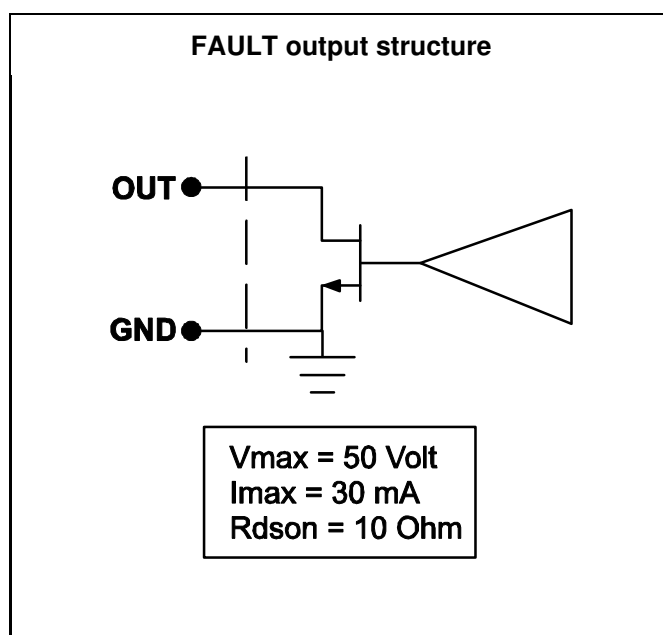

Fig. 1 b



NOTICES, HAZARDS AND CAUTIONS



- HGD series drives are BDM (Basic Drive Module), as defined in the EN 61800-3. They are sub-assemblies without a direct function, foreseen to be integrated in a more complex machine or installation by a professional assembler, expert in the field of motor drives and in their related problems. Only a professional assembler can install and put in service this component.
- CE marking: Products here described conform to 2006/95/CE and 2004/108/CE and further modifications, when correctly installed and used.
- They are intended to drive stepping motors with two phases, base step angle 1.8 degree and phase inductance between 1.0 and 12.0 mH. Use with different kind of motor is not allowed.
- Protection degree IP00: Use only inside a protective enclosure able to avoid electric shock hazard. All handling has to be done with drive switched off.
- Installation is allowed in local environment with pollution degree N° 2. Installation in presence of explosive and/or flammable and/or chemically aggressive and/or electrically conductive gas, vapour or dust and installation near easily flammable or heat sensitive materials is strictly forbidden.
- Use for safety related functions is forbidden (EN 60204-1); it is also forbidden any application arrangement in which a driver fault or failure could generate a hazardous condition. It is forbidden to use this material in application covered from one or more EEC directive before the conformity to those directives has been declared.
- Residual voltages: depending on supply type (assembled by user) and application conditions, a waiting time greater than 5 seconds after switching off could be necessary.
- Scald hazard: due to the presence of some components operating at high temperature (120°C), wait some minutes after switching off in order to avoid scalds.
- Driver could generate electromagnetic interference (both radiated and conducted) if instruction about installation directions are not respected (chap. 6). We remember however that compliance to 2004/108/CE directive has to be tested on whole machine in normal working condition.
- In case of drive failure, dangerous high voltage could appear at these terminals, also if this event is extremely rare. For this reason, from the point of view of evaluation of the machine safety during a single fault condition, the external control system, connected to these inputs, has to be considered potentially subjected to V_{DC} high voltage, unless an external separation is provided.
- Insulation of the drive parts is dimensioned for pollution degree N° 2 and for overvoltage class II. The drive can't be connected to the main and it has to be supplied by a power supply equipped with transformer main insulation.

HGD 02/05 DRIVE EXTERNAL CONNECTION EXAMPLE

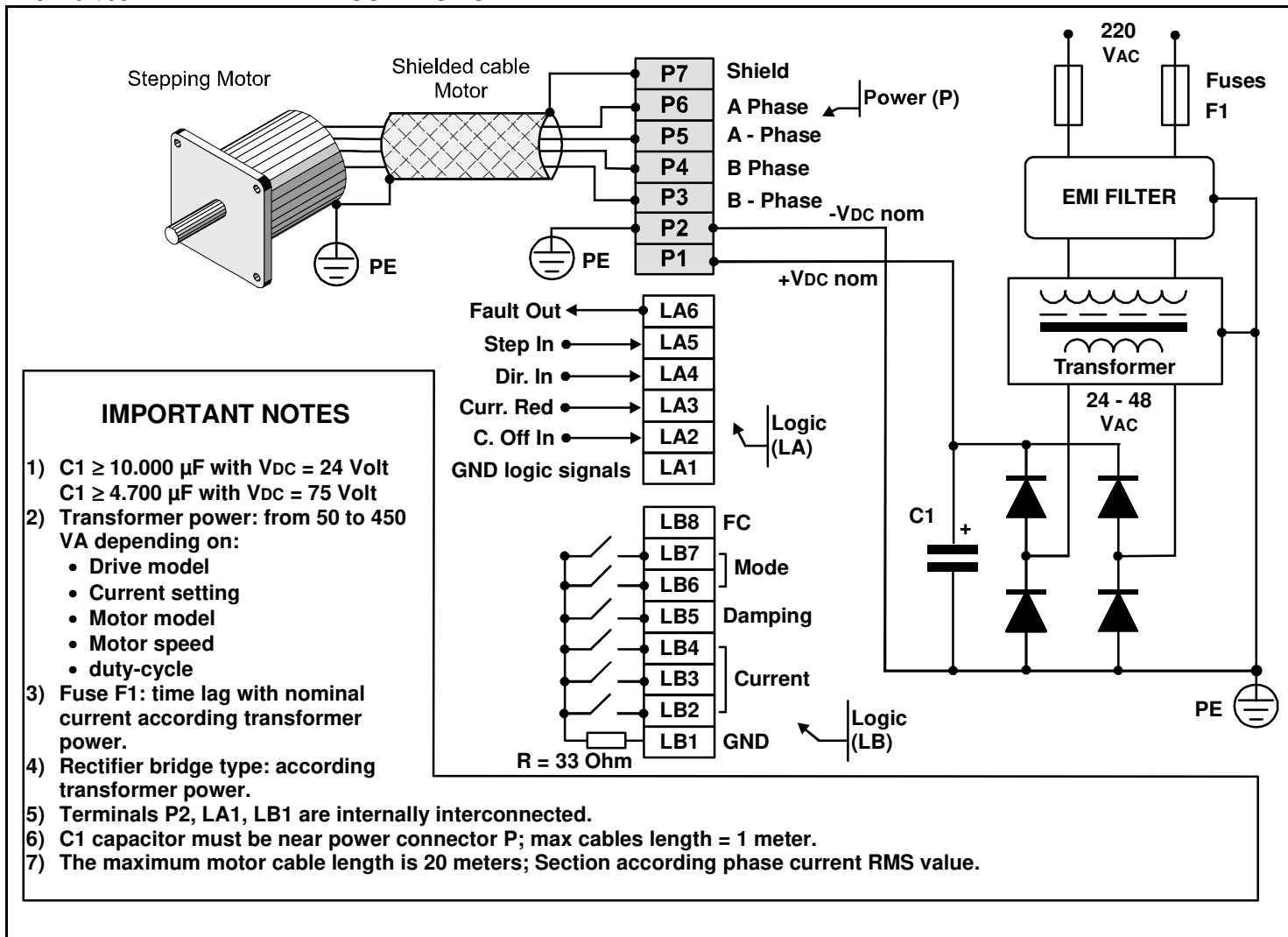

Fig. 2

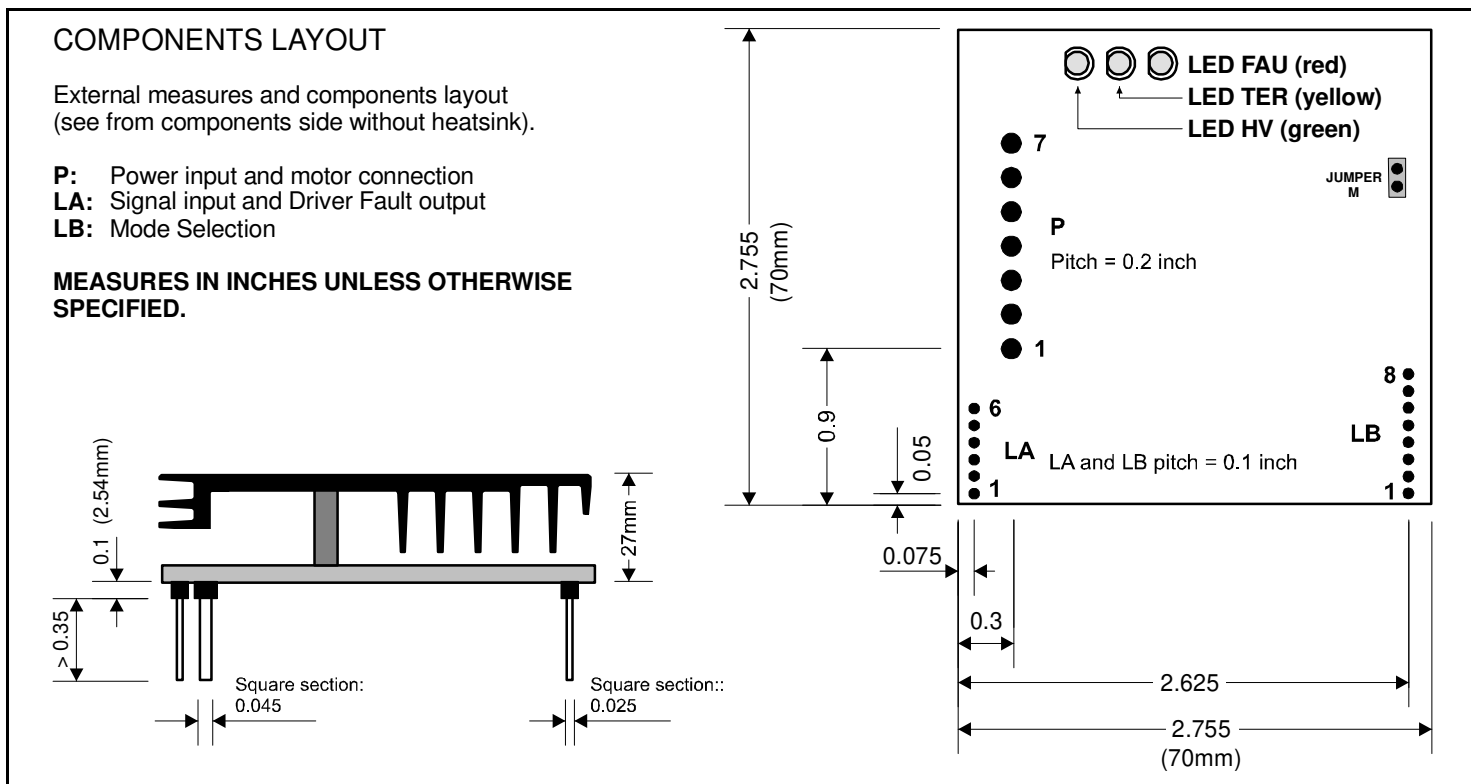

Fig. 3