

# QUICK START GUIDE

## MC404-Z

## SAFETY WARNING

During the installation or use of control systems, users of Trio products must ensure that there is no possibility of injury to any person or damage to machinery.

Control systems, especially during installation, can malfunction or behave unexpectedly. Bearing this in mind, users must ensure that even in the event of a malfunction or unexpected behaviour, the safety of an operator or programmer is never compromised.

### ETHERNET CONNECTOR (RJ45)

A standard Ethernet connector is provided for use as the primary programming interface.

The Trio programming software, *Motion Perfect*, must be installed on a Windows based PC that is fitted with an Ethernet connection.



Ethernet cable must be CAT 5e SF/UPT or better. (See EMC guide.)

### SD CARD

The micro-SD Card slot allows a simple means of transferring programs, firmware and data without a PC connection. It Offers the OEM easy machine replication and servicing.

The memory slot is compatible with a wide range of micro-SD cards up to 32 GB using the FAT32 compatible file system.

### IP RESET

To reset the IP \_ ADDRESS, IP \_ GATEWAY and IP \_ NETMASK to their default values press the IP reset button and power cycle the controller while keeping the button pressed.

The factory default IP address is 192.168.0.250. This can be changed using the ETHERNET or IP\_ADDRESS commands via *Motion Perfect*. To return to the factory IP address, hold the IP address reset switch in while powering up.

## POWER / DIGITAL OUTPUT CONNECTOR (NPN)

This is a 12 way 3.5mm pitch connector. Pins 1 to 4 are used to provide the 24 Volt power to the MC404-Z. A 24V dc, Class 2 transformer or power source must be provided as this powers the unit.



**THE 24V AND 0V (MAIN BOARD PIN 1 AND 2) MUST BOTH BE CONNECTED AS THEY POWER THE MC404-Z.**

**THE 24V AND 0V (OUTPUT CIRCUIT PIN 3 AND 4) MUST BOTH BE CONNECTED AS THEY POWER THE MC404-Z OUTPUT CIRCUIT.**

**THE MC404-Z IS EARTHED VIA THE METAL CHASSIS PLATE.**

Pin	Function	Pin	Function
1	24V (Main board)	7	OP10
2	0V (Main board)	8	OP11
3	24V (Output circuit)	9	OP12
4	0V (Output circuit)	10	OP13
5	OP8	11	OP14
6	OP9	12	OP15

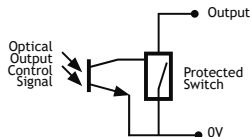
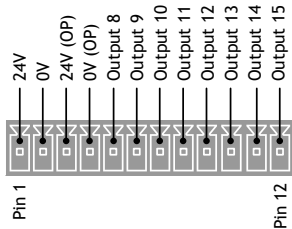

## DIGITAL INPUT CONNECTOR (NPN / PNP)

Pin	Function	Pin	Function
1	Common Bank 0	10	Common Bank1
2	IN0	11	IN8
3	IN1	12	IN9
4	IN2	13	IN10
5	IN3	14	IN11
6	IN4	15	IN12
7	IN5	16	IN13
8	IN6	17	IN14
9	IN7	18	IN15

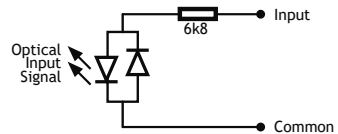
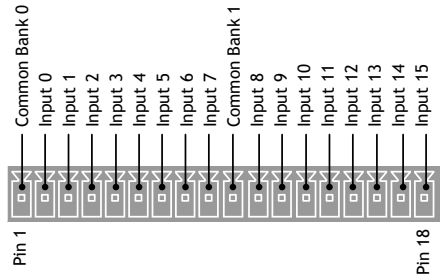

## STEPPER AXIS CONNECTOR (0-2)

9 way D-type Axis connectors	
Pin Number	Axis 0 to 2 (Stepper)
1	Step+
2	Step-
3	Dir+
4	Dir-
5	0V Step
6	Enable+
7	Enable-
8	N/C
9	N/C

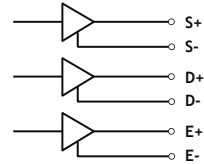
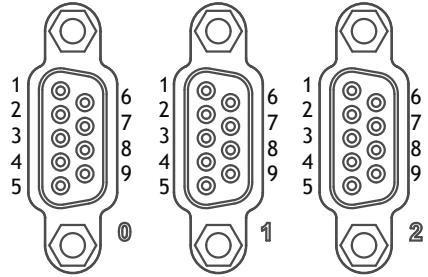

RS422 Line Driver

## STEPPER OUT / ENCODER IN AXIS CONNECTOR (3)

9 way D-type Axis connector		
Pin Number	Axis 3 (Stepper OR Encoder)	
	Encoder In	Stepper Out
1	Enc. A	Step+
2	Enc /A	Step-
3	Enc B	Dir+
4	Enc /B	Dir-
5	0V Enc	0V Step
6	Enc Z	Enable+
7	Enc /Z	Enable-
8	5V*	5V*
9	N/C	N/C

\*5V supply is limited to 150mA

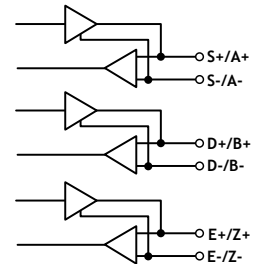
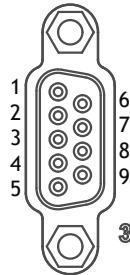

RS422 Line Transceiver

## AUXILIARY CONNECTOR

15 way Auxiliary D-Sub Connector		
Pin Number	Function	Note
1	RS232 Transmit	Serial Port #1
2	RS485 Data In A Rx+	Serial Port #2
3	RS485 Data Out Y Tx+	Serial Port #2
4	0V	
5	AIN (Analogue In)	0V to 10V max, 12 bits
6	WDOG+	Positive Solid State Output
7	CAN HIGH	CANBUS
8	0V	
9	RS232 Receive	Serial Port #1
10	RS485 Data In B Rx-	Serial Port #2
11	RS485 Data Out Z Tx-	Serial Port #2
12	0V	
13	AOUT (Analogue Out)	0V to 10V max, 10 bits
14	WDOG-	Negative Solid State Output
15	CAN LOW	CANBUS

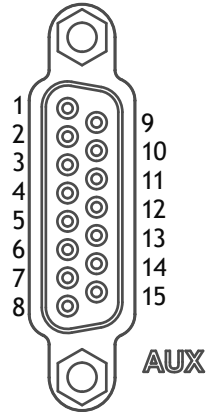

## GROUNDING AND SHIELDING

Good quality screened cables should be used for the auxiliary port. The serial ports and CANbus port are not galvanically isolated, therefore the 0V return **MUST** be connected to all peripheral devices. In addition, bond together the 0V (24V return) terminals of all system components so as to minimise current flowing in the serial cables.

Ensure that:

1. 0V connection is NOT used for terminating screens.
2. For fully opto-isolated inputs on the drive, the 0V may be omitted.
3. Screen should be connected to either 9 or 15 way D-type shell.
4. The MC404-Z 24V supply has common 0V with the drive(s).



**WHEN WIRING MC404-Z STEPPER OUTPUTS TO A NON-ISOLATED DIFFERENTIAL INPUT STEPPER DRIVE, USE THE 0V AND SHIELD CONNECTIONS SHOWN FOR THE ENCODER. THE STEPPER DRIVE MUST HAVE ITS COMMON 0V CONNECTED TO THE MC404-Z 24V RETURN.**

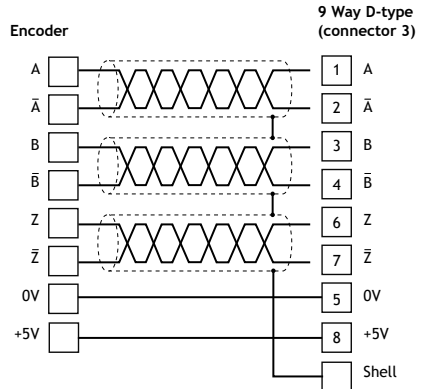
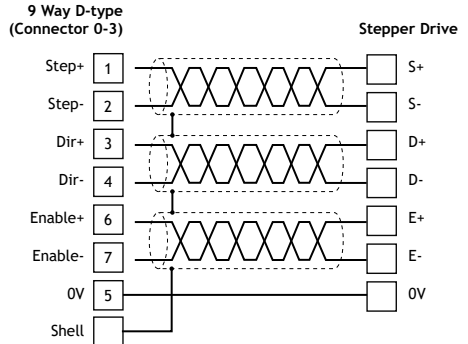

## LED STATUS INDICATORS

Display at start-up

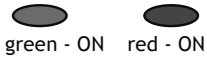

Display with WDOG on

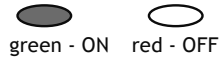

Display Error



## CHASSIS MOUNTING DIMENSIONS (LOOKING FROM REAR)

M4 screws should be used in 3 places to mount the MC404-Z to an unpainted earthed metal panel.

Best EMC performance is obtained when all 3 screws are attached to the metal back panel.

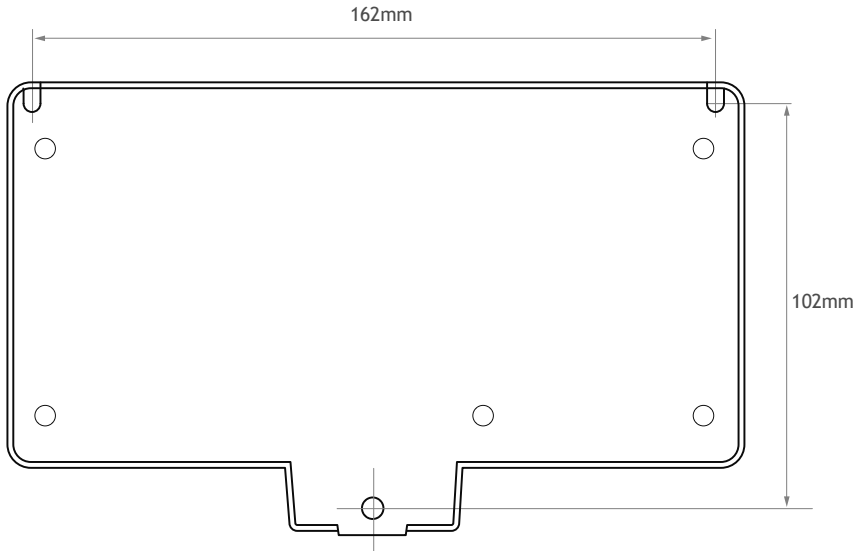

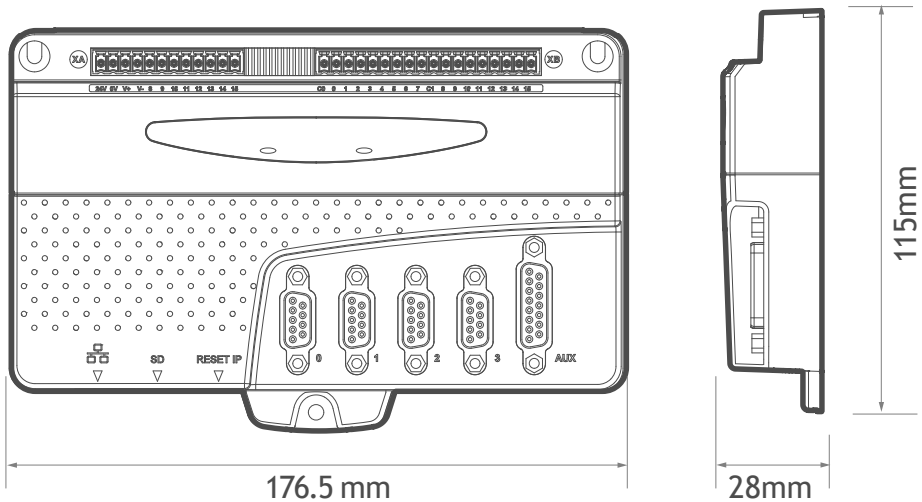

---

UK | USA | CHINA | INDIA  
**WWW.TRIOMOTION.COM**  
THE MOTION SPECIALIST

---

CAD data Drawings to aid packaging and mounting are available in various formats from the Trio web site. Products should be wired by qualified persons.  
Specifications may change without notice. E & OE

Quick Start v1 October 2020