



MOTION CONTROL SYSTEMS

PLUS E SERIES

STEPPING MOTOR DRIVES

INSTRUCTION MANUAL



R.T.A. s.r.l.

Via E. Mattei – Frazione DIVISA
27020 MARCIGNAGO (PV)
Tel. +39.0382.929.855 - Fax +39.0382.929.150
Internet: <http://www.rta.it> - e-mail: info@rta.it

**R.T.A.
DEUTSCHLAND GmbH**









Bublitzer Straße, 34
40599 DÜSSELDORF (Germany)
Tel. +49.211.749.668.60-Fax +49.211.749.668.66
Internet: <http://www.rta-deutschland.de>
e-mail: info@rta-deutschland.de

**R.T.A. IBERICA
MOTION CONTROL SYSTEMS S.L.**

C/Generalitat 22, 1º 3º
08850 GAVA – BARCELONA (Spain)
Tel. +34.936.388.805-Fax +34.936.334.595
Internet: <http://www.rta-iberica.es>
e-mail: info@rta-iberica.es



INDEX

1 -	NOTICES AND MANUAL STRUCTURE	3
2 -	  LIMITATIONS, HAZARDS AND CAUTIONS	4
3 -	GENERAL CHARACTERISTICS AND IDENTIFICATION	6
4 -	INPUT AND OUTPUT LOGIC SIGNALS	7
5 -	INPUTS AND OUTPUTS POWER LINES	9
6.	DRIVE SETTING AND ALERT SIGNALS.....	10
7.	DRIVE EXTERNAL CONNECTIONS	14
8.	  INSTALLATION AND ENVIRONMENT LIMITS.....	15
9.	LOGIC INTERFACING EXAMPLES	16
10-	  EMC NOTES	18
11-	  APPLICATION NOTES.....	20

WARNING: it is user **RESPONSIBILITY** to check that this manual refers to product model and version that will be used

Symbol meaning



The section marked with this symbol contains warnings regarding safety problems. If the directions indicated in these sections are not fulfilled, it could arise hazardous situations .



The section marked with this symbol contains information regarding operations which are strictly forbidden.



1 - NOTICES AND MANUAL STRUCTURE

1.1 - This manual covers the following items:

- PLUS E series stepping motor drives in all their standard versions.
- Standard characteristics of special versions of PLUS E series stepping motor drives (see chapter 1.2).
- For models and versions identification see also chapter 3.

1.2 - For the purposes of this manual the terms used assume the meaning below described (see fig. 1).

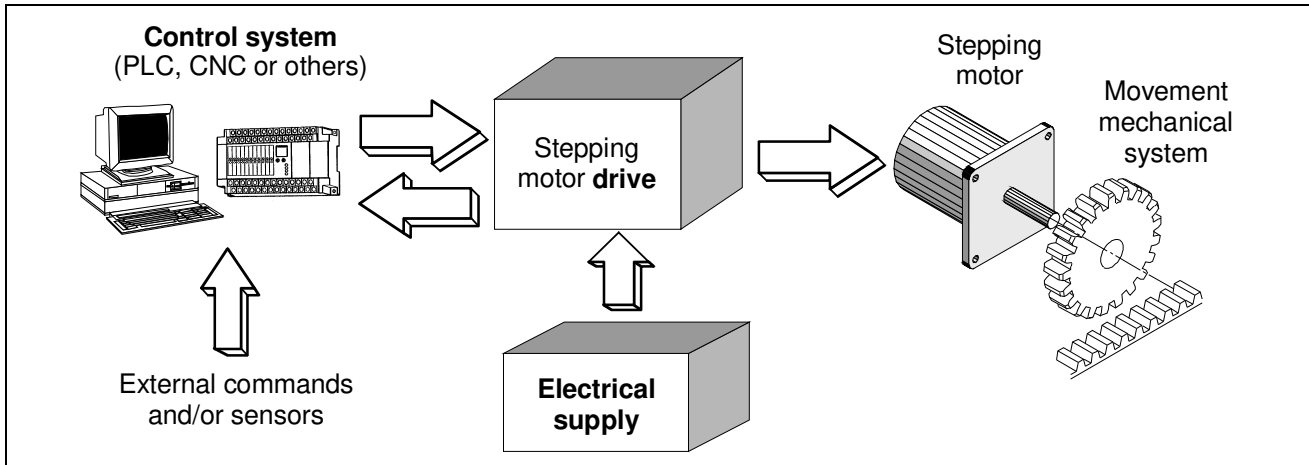

Fig. 1

- Drive: electronic part of an electromechanical motion system, which receives some digital or analog input signals from an external control system and gives to the stepping motor the suitable phase excitation sequences, in order to obtain the mechanical movements required by the control system. The drive can also communicate its status to the control system through some logic signals. In this manual we consider the drive as a BDM (EN 61800-3, chap.3, Fig.1).
- Control system: part of the machine which decides and controls all machine functions and gives to the drive all execution commands. It could be a numerical or programmable control, a personal computer or a specific control card. In the simplest machines it could also be a group of sensors and electromechanical switches.
- Electrical supply: all machine parts suitable to supply the drive in a correct way; usually filter capacitor, transformer separating from the main, anti-interference filter and all switches and protection systems.
- Standard drives are all models (see chapter 3 for identification) whose characteristics comply completely with those described in this manual. Special versions are all models in which some characteristics differ from the description given in this manual. For these models, some part of the manual does not apply and, in these cases, you must have the specific "variation sheet" which becomes an integral part of the manual itself.

1.3 - Products described in this manual (see list in chapter 1.1 and identification code in chapter 3) are CE marked and comply with the following directives:

- 1) Low Voltage (2006/95/CE and further modification).
- 2) Electromagnetic Compatibility (2004/108/CE and further modification).

1.4 - Remember that, as stated in all directives, compliance exists only when a product is used in accordance with its destination and following manufacturer prescriptions. Thereby, all relevant indications about use, cautions, installation and limitations here described must be followed by user in order to stay within compliance limits: from this point of view, chapter 2, 8 and 10 are particularly important, but the entire content of this manual has to be carefully read and considered in order to obtain the information necessary for a correct use.



- 1.5 - Conformity declaration regarding above mentioned products is kept by R.T.A. (as manufacturer residing in EEC country) together with technical construction file at authority disposal.
- 1.6 - This manual is conceived in a way to offer to the personnel involved in project and safety verification of a machine all information concerning characteristics, working conditions, application limits and cautions about PLUS E series stepping motor drives. The knowledge of this information is essential for a correct project of machines, apparatus and systems in which the drives are used, it is strongly recommended not to start any operation with the drives before you have completely read and understood the content of this manual. If you find some part of this manual not completely understandable or lacking regarding your particular application, do not hesitate to contact directly R.T.A. that can provide, if necessary, further information in order to make the user able to design his machine and the related safety systems in the best way. Take into account that an incorrect use or installation, a wrong dimensioning of external safety elements related with the drive could bring to economical damages and also to hazards for human life.
- 1.7 - Consider the fact that these are products with a very wide range of possible applications in many different working and environment conditions. For this reason this manual can only fix limits and general rules but cannot take in consideration every single possible application condition. If you have problems to understand some part of this manual or to meet its indications with your specific application, do not hesitate to contact R.T.A. for further information. Take into account that R.T.A. has twenty years of experience in any kind of applications, which cannot be condensed in a manual but can always be at customer disposal.
- 1.8 - The terms "user and customer" often used in this manual always indicate a skilled person as defined in chapter 2.9.
- 1.9 - This manual is considered valid at the moment of the selling of the product. It cannot be considered inadequate as a consequence of product or manual changes or improvements after the selling. R.T.A. reserves the right of products and manual revisions without notice neither obligation of previous products and manuals revision.

2 - LIMITATIONS, HAZARDS AND CAUTIONS

- 2.1 - PLUS E series drives are suitable to drive two phases stepping motors with 4, 6 or 8 terminals. Their use for different purposes is not allowed.
- 2.2 - It is not allowed the use of these drives for any purpose different from the one above indicated.
- 2.3 - It is also not allowed the use in any condition not complying with one or more specific limitations stated in this manual for electrical, mechanical and environmental quantity or characteristics.
- 2.4 - PLUS E series drives are classified as protection degree IP20. This means that they must be located inside a protective enclosure meeting requirements of standards applicable in the specific application in which they are used.
- 2.5 - PLUS E series drives have some dip-switches. They perform some adaptations (to the particular motor, to application, etc). **All these settings have to be made with the machine switched off, before putting it in service;** none of them requires the machine switched on.
- 2.6 - PLUS E series drives and related power supply contain capacitors able to store a certain amount of electrical energy. As a consequence, in some cases, according with application conditions and supply dimensioning, a dangerous voltage could remain on the drive, after switching off, for a time greater than 5 seconds. So it is recommended to wait an adequate time before working on the drive.
- 2.7 - The heatsink can reach high temperatures during normal working conditions (for example about 80 °C). Do not touch this component for some minutes, after switching off, in order to avoid scald hazard.
- 2.8 - After a failure due to connection mistakes or others, in the drives could arise a temporary hot spot. For this reason avoid absolutely to install in explosive or flammable environments. **Avoid also to install near easily flammable materials and components;** we recommend to verify that all the components located in the enclosure are realized using self-extinguishing materials.



- 2.9 - All products considered in this manual are sub-assemblies without a direct function, foreseen to be integrated in a more complex machine. Only a professional assembler, expert in the field of motor drives and in their related problems, can install and put in service this component. It is exclusive responsibility of the designer of the complete machine or installation in which this component is used to take care of the safety and reliability of his project. It is forbidden to use this material in application covered from one or more EEC directives (for instance 2004/108/CE, 2006/42/CE, etc.) before the conformity to those directives has been declared. Regarding 2004/108/CE directive, see chapter 10.
- 2.10 - Use for safety related functions is forbidden (EN 60204-1). Moreover, when the application arrangement is in such way that a drive fault or failure could generate a dangerous condition, external independent safety protection system must be provided in the machine.
- 2.11 - In some case of drive failure, dangerous high voltage could appear at logic low voltage input and output terminals, even if this event is extremely rare. For this reason, from the point of view of evaluation of the machine safety during a single fault condition, the external control system, connected to these inputs, has to be considered potentially subjected to high voltage, unless an external separation is provided.
- 2.12 - Both CURRENT OFF input signal (see chapter 4) and internal electronic functional protections (see chapter 6) switch off the drive output power by means of semiconductor devices. They cannot be used to interrupt power in emergency stop function or in any function involving personnel safety.



3 - GENERAL CHARACTERISTICS AND IDENTIFICATION

3.1 - DIMENSIONS

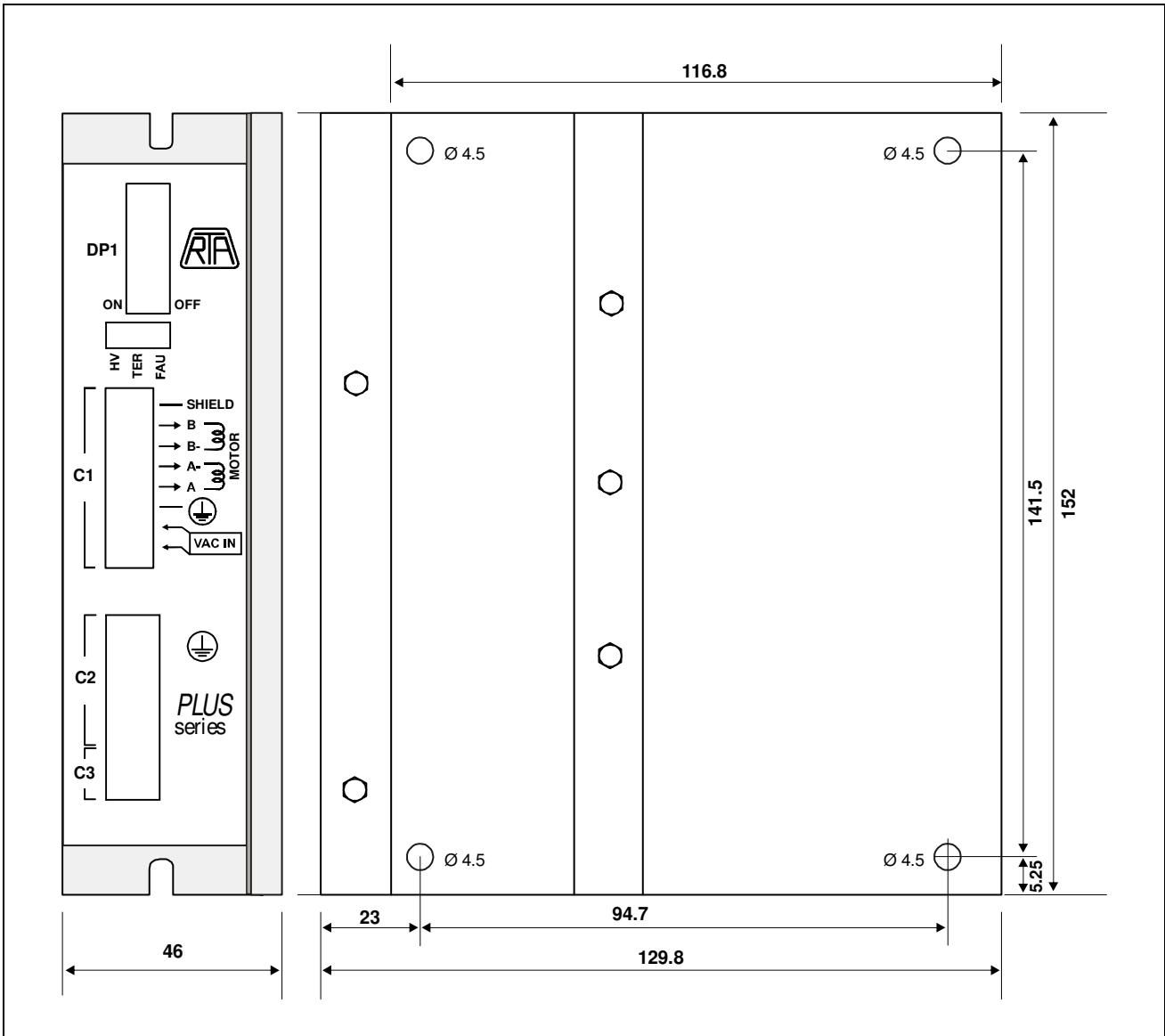

Fig. 2 – Dimensions: all measures in mm.

3.2 - IDENTIFICATION

The models identification of PLUS E series drives is as follows:

PLUS EX.Y

where:

X can be: 3 or 4 and identifies a standard model with encoder.

.Y is not present in standard models. If present **Y** can be a number or an alphanumeric character identifying a special version with some variations with respect to standard models.

Each sample is also identified with a serial number.



4 - INPUT AND OUTPUT LOGIC SIGNALS

(C2 Connector, see Fig. 2, 4 and 6)

In the following are listed enable input and output logic signals.

All inputs are CMOS with following features:

LOW LEVEL = $V_{in} < 1 \text{ VOLT}$; HIGH LEVEL = $V_{in} > 2.5 \text{ VOLT}$

All outputs are optically insulated among them and from internal power circuits.

- 11 COMMON OF OUTPUTS.**
- 12 DRIVER FAULT OUTPUT:** When this output is SHORTED, drive is normally working; when it is OPEN drive is in no-working state. Drive automatically goes in no-working state when some protection is active and automatically recovers when the protection resets.
- 13 SYNCHRONISM LOSS ALARM OUTPUT:** When this output is SHORTED, the motor is correctly working; this output OPEN when the angle between real and theoretical position of the motor goes over the ENCODER SENSITIVITY value. For using this output see Chap.6.5 and Chap 11.
- 14 STEP INPUT (STEP operation mode):** Step is performed on active transition of this signal. See chap. 6.5. Suggested duty-cycle: 50%. Max. frequency: 60 KHz with square wave signal supplied from an output with low impedance ($< 300 \text{ Ohm}$). In any case STEP signal half period has to be higher than $8 \mu\text{sec}$. **See NOTE.**
- 15 DIRECTION INPUT:** if this signal is HIGH, the motor rotation direction is opposite to the one obtained when this input is LOW. This signal has to be set up at least $100 \mu\text{s}$ before STEP signal and has to stay in this state for at least $100 \mu\text{s}$ after last STEP sent to the drive.
- 16 CURRENT OFF INPUT:** when this signal is HIGH drive is active. When it is LOW drive is inhibited, thus motor current (and so holding torque) is turned to zero.
- 17** This input can have two distinct functions, to set by means of DIP-SWITCH (Dip 3 of DP2, see chap. 6.5):
- MULTIPLIER X4 (MULTIPLIER operation mode):** When this input (17) is HIGH pulse sent to STEP INPUT are multiplied by four. It is used with operation mode marked by \times in the tables of chap. 6.4 and chap. 6.5. This signal has to be valid at least 2 ms before STEP signal and has to stay in this state for at least 2 ms after last STEP sent to the drive. **SEE NOTE.**
- ENCODER ALARM SENSITIVITY SETTING (ZERO operation mode):** When this input is HIGH, encoder sensitivity is set to 1.8° ; otherwise sensitivity is set with dip 4 and dip 5 of DP1 (see Table 4 of Chap. 6.4). This signal has to be valid at least 2 ms before STEP signal and has to stay in this state for at least 2 ms after last STEP sent to the drive.
- 18 ENCODER RESET INPUT (MANUAL ENCODER RESET mode):** The SYNCHRONISM LOSS ALARM is reset on active transition of this input. For using this input see Chap.6.5 and Chap 11.
- 19 INTERNAL GND:** Logic signals return. It is internally connected to terminals 1 and 6 of C1 connector and 24 of C3 connector). This terminal is galvanically insulated from logic outputs (11, 12, 13).
- NOTE:** The maximum mechanical speed of the motor is 3500 rpm. Avoid combination of STEP frequency, MULTIPLIER X4 and resolution that over this limit.

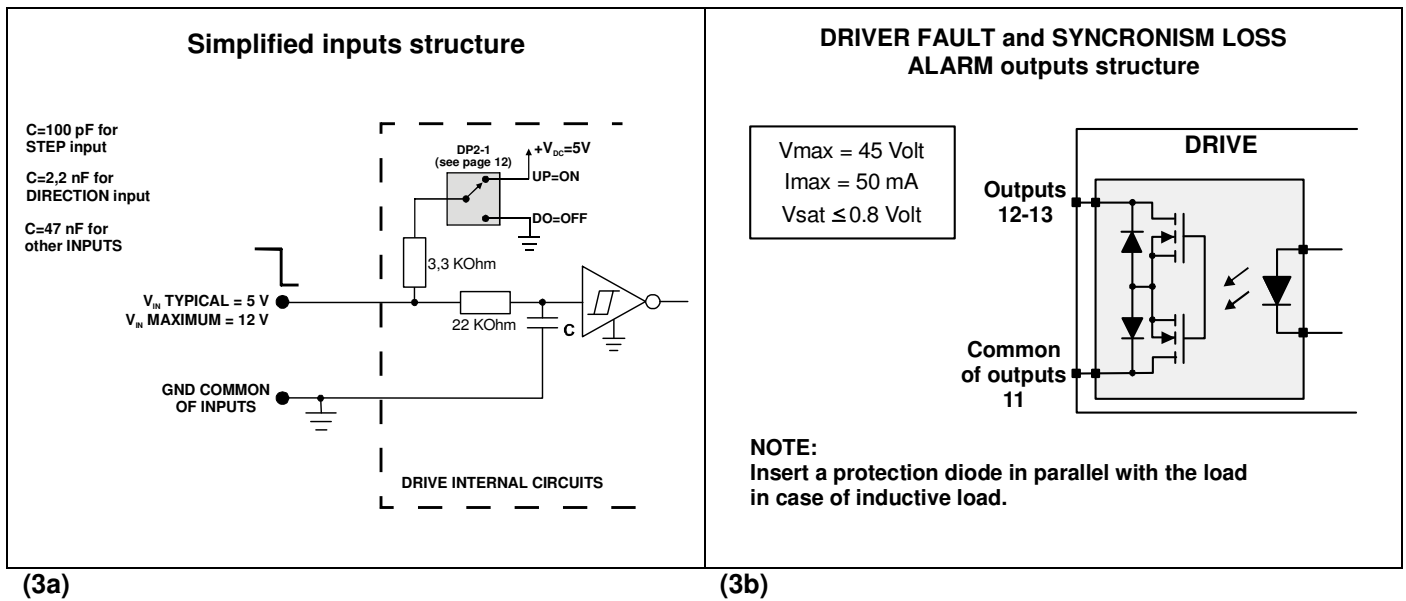

Fig. 3 – Inputs and outputs scheme.

ENCODER INPUTS (C3 Connector, see Fig. 2, 4 and 6)

In the following are described enable signals:

- 21 **V+ ENC:** Positive encoder power supply (5Vdc).
- 22 **ENC_B:** Phase B encoder.
- 23 **ENC_A:** Phase A encoder.
- 24 **INTERNAL GND:** Negative encoder power supply. Internally connected to 1 and 6 terminals of C1 connector and 19 of C2 connector.

To C3 connector are connected encoder used in connection with RTA EM XXXX-04S0 series motors only.
Example of suitable motors : EM 3F1H-04S0; EM 3F2H-04S0; EM 3F3H-04S0.



5 - INPUTS AND OUTPUTS POWER LINES

In this chapter drive inputs and outputs power lines and the required power supply lines are described.

5.1- Drive power outputs are the four phase lines driving the stepping motor winding. Drive power inputs are the two connection lines to V_{ACnom} . All connector C1 terminals are listed in the following Table 1.

TABLE 1	
CONNECTOR C1	DESCRIPTION
1	Shield of shielded motor cable
2	Motor winding terminal B (RED)
3	Motor winding terminal B- (YELLOW)
4	Motor winding terminal A- (BLUE)
5	Motor winding terminal A (ORANGE)
6	GND
7, 8	Power supply

5.2- Earth terminal – Earth terminal is on the frontal panel in the middle of it and has to be electrically connected to earth (PE terminal of the machine in which the drive is installed).

5.3- The terminal indicated as GND is the point of motor-drive system that has to be connected to earth (PE terminal) in order to guarantee the correct operation of some drive protection systems. No other point at a different potential of logic circuit and of power circuit has to be connected to earth; in particular has not to be connected to earth transformer secondary winding. Shield of shielded cables of motor outputs must be connected to terminal 1 of C1 and shield of shielded cables of signal and encoder outputs must be connected to PE with connection with less possible length. Furthermore it is important to note that GND terminal (6) is internally connected to terminal 1 of C1, to terminal 19 of C2 and to terminal 24 of C3. See connection schemes of Fig. 6, 13 and 14.

5.4- Table 2 shows power inputs and outputs characteristics:

TABLE 2		PLUS E3	PLUS E4
$V_{AC\ nom}$	(VOLT)	from 28 to 62	from 55 to 100
$I_{NP\ min}$	(AMP)	2.4	1.9
$I_{NP\ max}$	(AMP)	8	6
Phase inductance	(mH)	from 0.8 to 12	from 1.2 to 12
Dimensions	(mm)	152 × 129 × 46	
Operating temperature		from +5°C to +40°C (see chap. 8.3)	

5.5- Definition of terms used in Table 2:

- $V_{AC\ nom}$: RMS value of alternate voltage at which the drive can be supplied.
- I_{NP} : indicates nominal phase current (peak value), which flows in each motor winding, it can be measurable with motor turning at **low speed**. The drive provides an automatic current reduction when the motor is in hold condition. Phase current is calibrated during the test phase and can be set by the customer, choosing between eight different values, by means of DIP-SWITCH.
- $I_{NP\ min\ and\ max}$: minimum and maximum nominal phase current value which can be set by user using DIP-SWITCH.



6- DRIVE SETTING AND ALERT SIGNALS

- 6.1- PLUS E series drives are general purpose products which can be used to drive many different motor models in different kind of applications. For this reason they have eight two-positions DIP-SWITCH suitable to adapt drive characteristics to the specific motor and/or application. **The setting of this dip-switch has to be made by customer before putting in service the drive. Do not forget to do these settings: wrong setting could get application errors and also motor damages and hazard conditions.** Three led indicate the drive status.
- 6.2- Fig. 4 shows the position of DIP-SWITCH DP1, alert LED, connectors and labels in PLUS E series drives.

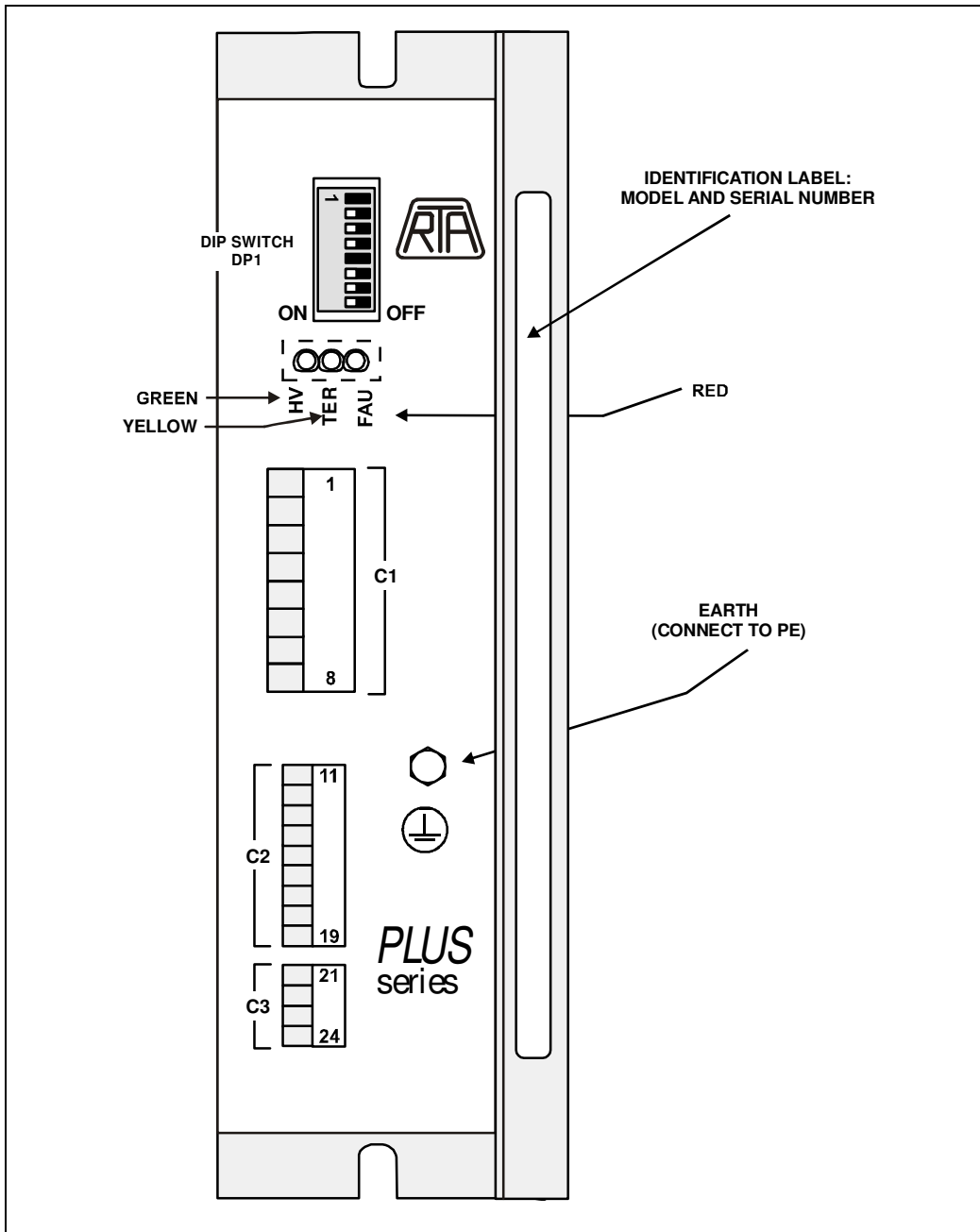

Fig. 4 – Dip-switch DP1, alert led and connectors.



6.3-Fig. 5 shows the position of DIP-SWITCH DP2 located on the bottom side of PLUS E series drives.

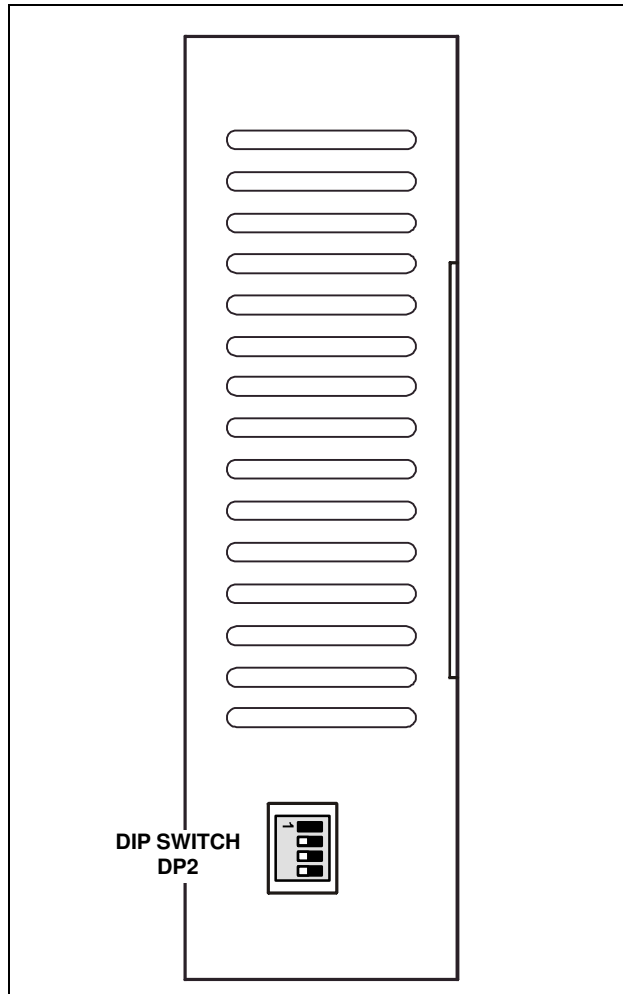

Fig. 5 – Dip-switch DP2 (PLUS E series drives bottom side view).

6.4-MAIN SETTINGS DIP-SWITCH DP1

Table 3 shows the position of dips 1, 2 and 3 (DP1) and the related motor nominal current.

DP1			NOMINAL CURRENT I_{NP} in Ampere	
Dip 1	Dip 2	Dip 3	PLUS E3	PLUS E4
ON	ON	ON	2.4	1.9
ON	ON	OFF	3.1	2.3
ON	OFF	ON	3.6	2.7
ON	OFF	OFF	4.3	3.1
OFF	ON	ON	4.5	3.6
OFF	ON	OFF	5.7	4.3
OFF	OFF	ON	6.8	5.1
OFF	OFF	OFF	8.0	6.0

Table 3

With dip 4 and 5 of DP1 (Table 4) it is possible to change the angle between theoretical and real position



of the motor at which a SYNCRONISM LOSS ALARM is given (output pin 13).

DP1		ENCODER SENSITIVITY (in degree)
DIP 4	DIP 5	
ON	ON	0.9°
ON	OFF	1.8°
OFF	ON	3.6°
OFF	OFF	5.4°

▶ **Table 4**

Table 5 shows the available steps/rev values corresponding to each specific dip (6, 7 and 8 of **DP1**) configuration.

DP1			STEPS FOR REV.
Dip 6	Dip 7	Dip 8	
ON	ON	ON	4.000 x
ON	ON	OFF	2.000 x
ON	OFF	ON	1.000
ON	OFF	OFF	500
OFF	ON	ON	3.200 x
OFF	ON	OFF	1.600 x
OFF	OFF	ON	800
OFF	OFF	OFF	400

▶ **Table 5**

▶ = default factory setting.

X = operation mode which allows internal STEP multiplier x 4 function.

6.5- MAIN SETTINGS DIP-SWITCH DP2

Table 5 shows the position of dip 1, 2, 3 and 4 of **DP2** (see Fig. 5) and corresponding operation mode.

DP2				OPERATION MODE
Dip 1	Dip 2	Dip 3	Dip 4	
▶ ON	-	-	-	PULL UP internal resistor (see Fig. 3a – NPN input) STEP transition = HIGH to LOW STEP×4, ENCODER SENSITIVITY, RESET ENCODER=active LOW
OFF	-	-	-	PULL DOWN internal resistor (see Fig. 3a – PNP input) STEP transition =LOW to HIGH STEP×4, ENCODER SENSITIVITY, RESET ENCODER=active HIGH
-	ON	-	-	DAMPING ENABLED
-	OFF	-	-	DAMPING DISABLED
-	-	ON	-	ZERO operation mode
▶ -	-	OFF	-	MULTIPLIER operation mode
-	-	-	ON	MANUAL ENCODER RESET mode
▶ -	-	-	OFF	AUTOMATIC ENCODER RESET mode

Table 5



MULTIPLIER operation mode: in this operation mode, when input 17 is active, number of steps in STEP input are multiplied X4. You can use this function only with resolution marked with x (see Table 5 of Chap. 6.4). This input has to be set at least 2 ms before STEP signal and has to stay in this state for at least 2 ms after last STEP sent to the drive.

ZERO operation mode: in this operation mode, when input 17 is active, encoder sensitivity is set to 1.8°, apart from sensitivity set with dip 4 and dip 5 of DP1 (see Tab. 4 of Chap. 6.4), allowing high precision ZERO SEARCHes; when input 17 is not active, sensitivity is the value (for example 5.4°) set with dip 4 and dip 5 of DP1, used for normal operation. In order to have a reliable SYNCRONISM LOSS DETECTION, see Chap. 11.4 and 11.5

MANUAL ENCODER RESET mode: in MANUAL mode reset is performed giving a pulse on RESET ENCODER INPUT (18) with the motor at standstill and without force acting on the motor. INPUT (18) has to be set at least 200 ms after last step sent to the drive and has to stay in this state for at least 2 ms; when it is disabled, wait for at least 2 ms before send a new step.

AUTOMATIC ENCODER RESET mode: In AUTOMATIC mode you will have an automatic reset at Power ON and, in case of SYNCRONISM LOSS alarm, 500 msec. after the last step on STEP IN and the last motor movement. When this operation mode is active, RESET ENCODER input (18) must not be used (see also Chap. 11.2).

DAMPING: Damping electronic circuit ensures low acoustic noise and reduces the amount of typical stepping motor mechanical vibrations. In any case, these can be reduced using higher values of steps /revolution in accordance with the maximum frequency produced by control system and with maximum revolution speed requested to the motor.

For example, in the case of control system generating a maximum frequency of 10 KHz and if the desired speed is equal to 600rpm = 10 revolutions/sec, 1000 steps/rev (=10.000/10) is the maximum resolution that can be used.

AUTOMATIC REDUCTION CURRENT: automatic current reduction is always active in this series driver; the current which flows in each motor winding is reduced to 50% of nominal current value nearly 50ms after the stop of the motor.

NOTE: Refer to Chap. 11 for a correct use of the drive.

6.6- This section shows the meaning of the alert LEDs.

LED HV (green): ON = supply voltage is in the correct operating range.
OFF = drive is not supplied or supply voltage is out of the correct range (in the second case also LED FAU is ON).

LED FAU (red): ON = drive is in no-working state due to one of the following protection:
b- Thermal protection (if LED TER is ON).
c- Max or Min supply voltage (if LED HV is OFF).
d- Short circuit or wrong motor connection (if LED HV is ON and LED TER is OFF).

OFF = drive is in working state if LED HV is ON.

LED TER (yellow): ON = drive in no-working state by thermal protection (in this case LED FAU is ON).

OFF = heatsink temperature is lower than the limiting value.

BLINKING:

- 1 FLASH = Min/max voltage protection memory
- 2 FLASHES = Thermal protection memory
- 3 FLASHES = Short circuit protection memory
- 4 FLASHES = Motor cable not connected (active with motor in stop state only)

All protection circuit and alarm reset itself when the alarm source vanish. Memory must be reset by removing power supply voltage.



7- DRIVE EXTERNAL CONNECTIONS

- 7.1- Design the power transformer: the power of transformer has to be higher than the sum of the power requested from drive and motor (total power). This one can be calculated as the sum of the following terms:
- Mechanical power delivered to load: mainly depending on application characteristics like friction, inertia, efficiency of mechanical transmission etc.
 - Motor losses: mainly depending on motor type, drive voltage, speed and duty cycle.
 - Drive losses: mainly depending on drive model, current setting and duty cycle; according with these parameters these losses can approximately vary between 60 and 130 Watt. It is often very hard to estimate drive and motor losses; in this case an over-dimensioning of the supply elements proportional to the inaccuracy is recommended. To get more accurate information, contact R.T.A. and describe the particular application. Obviously if a single power supply is used for more than one drive, the total power is equal to the sum of the single drive powers.
- 7.2- Transformer must meet the following requirements:
- Supply the correct voltage through a transformer secondary winding. The V_{AC} voltage value is intended as measured at secondary terminals in no load condition and with primary voltage equal to the nominal value. Maximum voltage drop at full power load must be less than 5%.
 - Ensure the galvanic insulation between the drive circuits and the main. **Remember that direct connection of drive circuits to the main is strictly forbidden. The use of autotransformer is strictly forbidden.**
 - Ensure the galvanic insulation between the drive circuits and all other circuits of the same machine. **This means that the drive dedicated transformer secondary has to be used exclusively for the drive.**
- 7.3- The use of one secondary winding for more drives (max 3 drives) is allowed only if the total power required by the drives is less than 600VA. In any case, two fuses (F1 and F2 showed in Figure 6) for each drive must be used.
- 7.4- **Branch circuit protection fuses F1 and F2 (see Fig. 6) must be 10 Amp, at least 250 Volt with I^2t between 150 A^2s and 400 A^2s (for example Cooper Bussman model KTK-R-10 or Littelfuse 215010.P).**
- 7.5- The cross-section area of conductors used in power supply circuit must be chosen according with power dimensioning (see 7.1). The cross-section area of the four shielded conductors connecting motor to the drive must be chosen with regard to the nominal current which has been set in the drive.

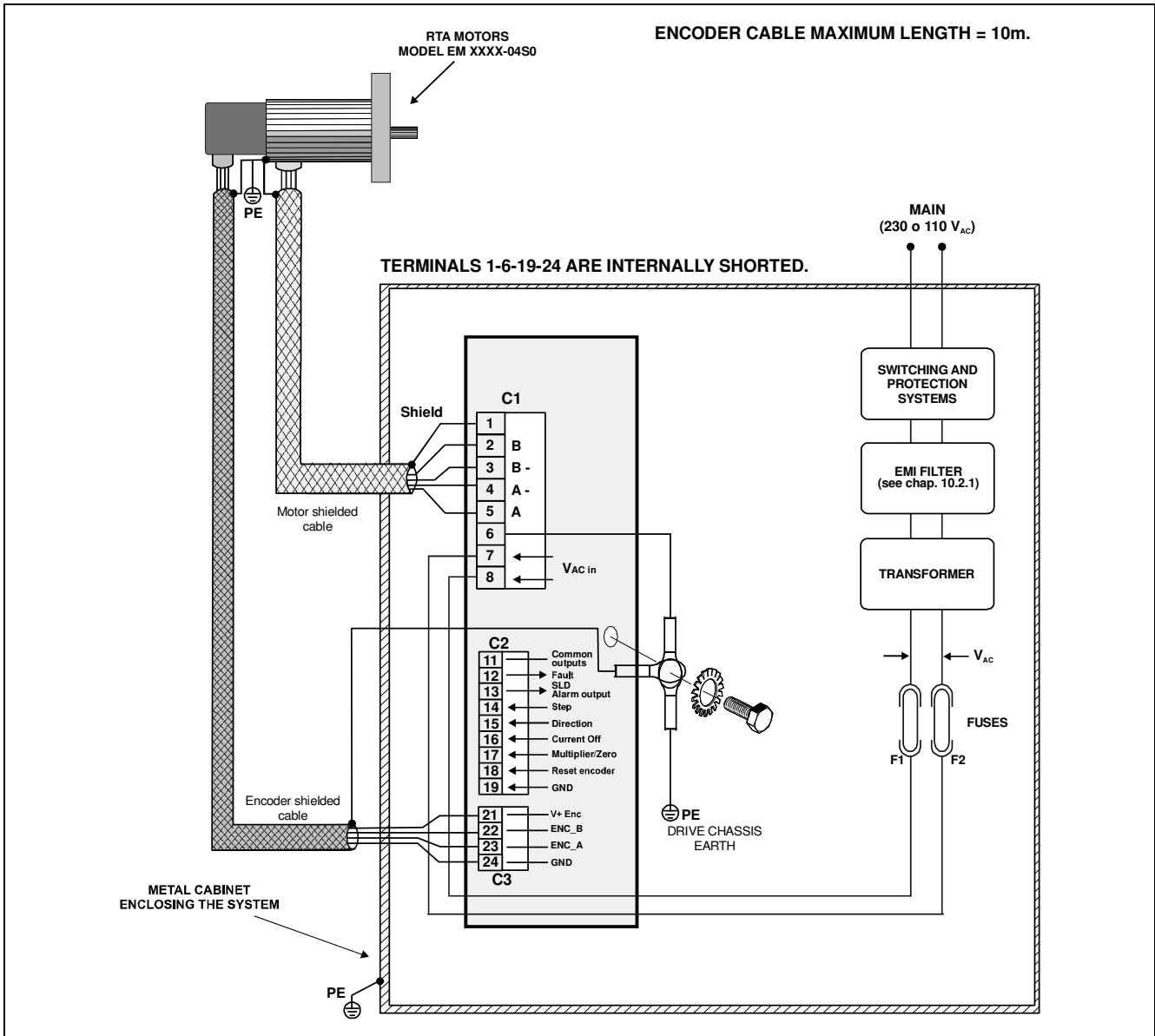

Fig. 6 – Drive external connections scheme.

8- ⚠️ 🚫 INSTALLATION AND ENVIRONMENT LIMITS

All products described in this manual are subjected to the following characteristics:

8.1-IP20 protection degree: it is user responsibility to provide an adequate protection enclosure suitable to meet the standards regarding the specific application in which the products are used.

8.2-Direct connection with the main is not allowed. Transformer separation is mandatory.

8.3-Installation and work environment. Installation is allowed in a micro-environment with:

- **Environment conditions class 3K3** (IEC 721-3-3): it includes a working temperature from +5°C to +40°C and relative humidity from 5% to 85% non condensing.
- **Pollution degree 2**: it includes that installation in environments in which explosive and/or flammable and/or chemically aggressive and/or electrically conductive gas, vapor or dust could be present is strictly forbidden.
- **Mechanical conditions class 3M1** (IEC 721-3-3).

If the environment in which the machine is used does not satisfy these conditions, suitable conditioning system or suitable case have to be used.



8.4-Storage environment limits with drive in its original packaging:

- Temperature: from -25°C to +55°C. Relative humidity: from 5% to 95%.
- Environment conditions class 1K3 (IEC 721-3-1). Pollution degree 2.

8.5-The drive generates some amount of heat (see chap. 7.1). This must be considered during the global electrical cabinet design. In order to ease air flowing around the drive, install the drive vertically (not turned upside down) with at least 5 cm of free space over and under the drive and 1 cm on the left and on the right of the drive. Do not obstruct air gratings.

9- LOGIC INTERFACING EXAMPLES

In this chapter some interfacing techniques are shown. They have to be considered only as examples. The best way to interface the drive with the control system can be chosen only with a complete knowledge of the control system and application requirements.

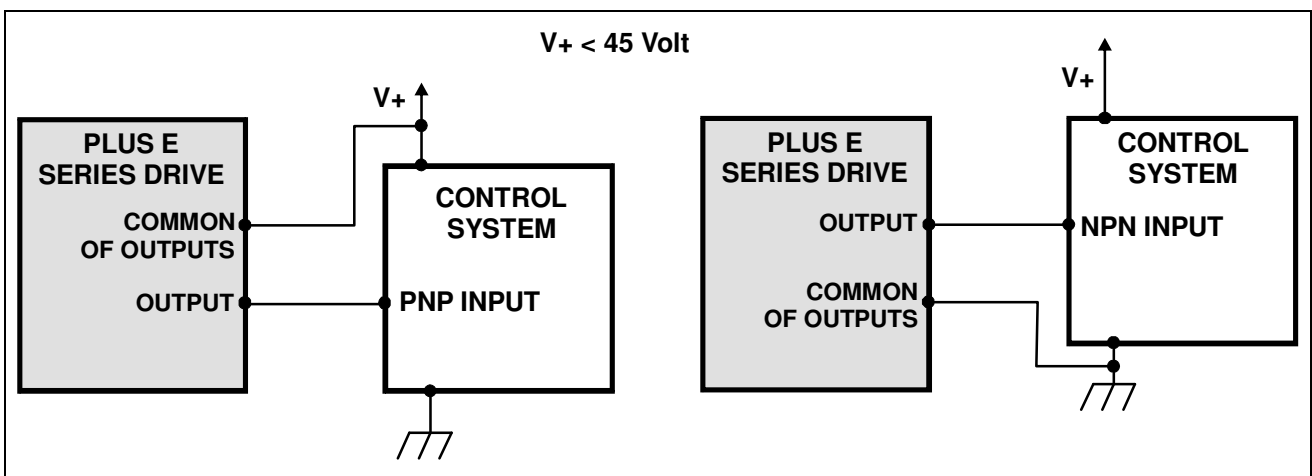

Fig. 7 – Electric connection between a PLUS E logic output and an input of a control system operating at $V+$ voltage.

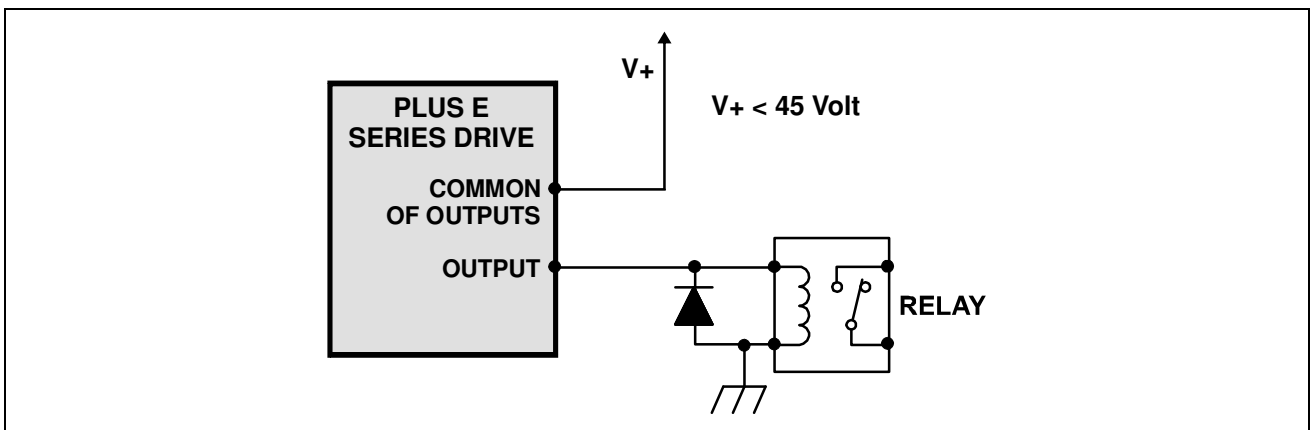

Fig. 8 - Driving a micro-relay by means of a PLUS E logic output.

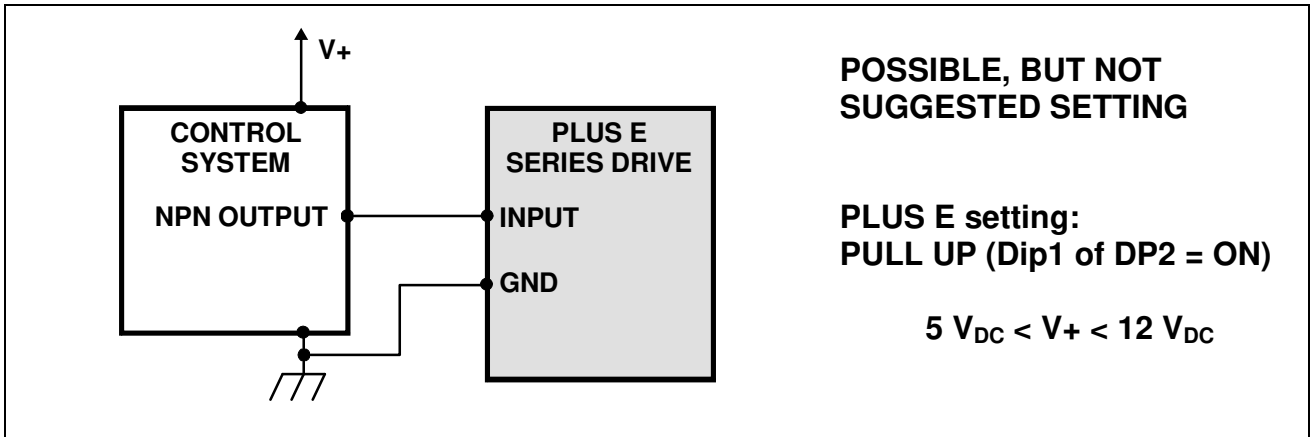

Fig. 9 - Driving a PLUS E logic input from a control system with a NPN open collector output.

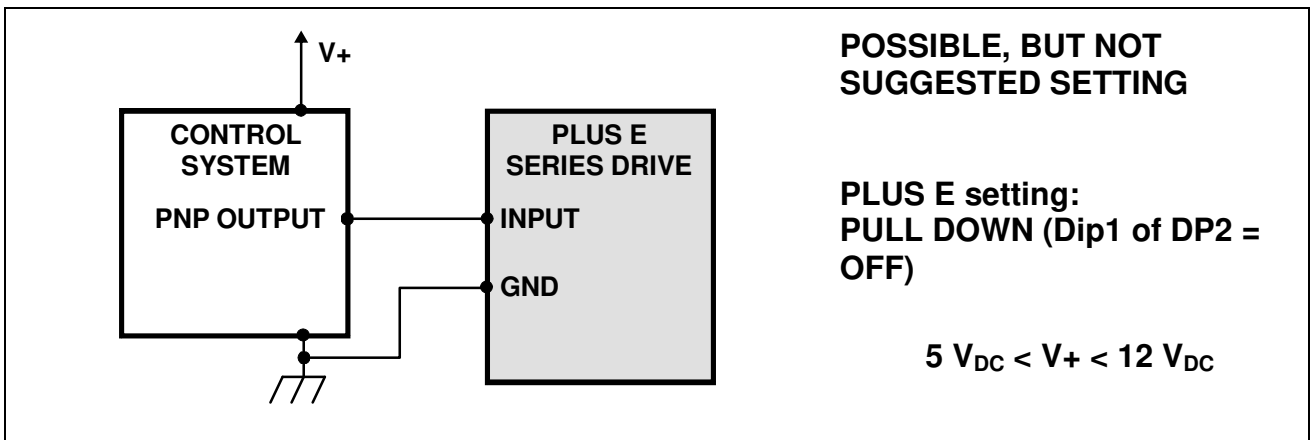

Fig. 10 - Driving a PLUS E logic input from a control system with a PNP output.

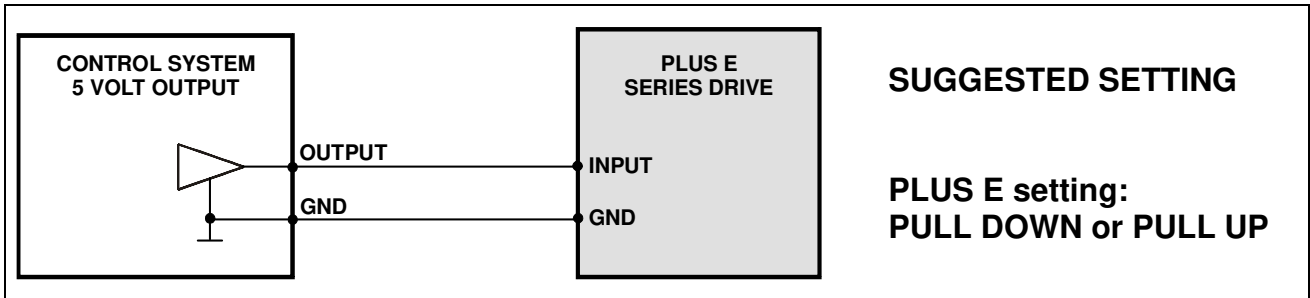

Fig. 11 - Connection example with control system with 5 Volt BUFFER output.

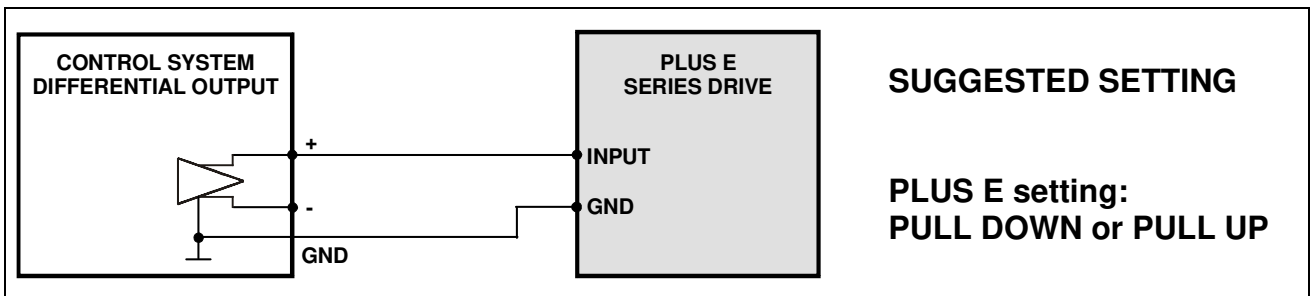

Fig. 12 - Connection example with control system with DIFFERENTIAL output (or LINE DRIVER or RS422).



10- EMC NOTES

- 10.1- Drive (or drives) power supply can not be used to supply other machines.
- 10.2- Electromagnetic compatibility (directive 2004/108/CE). PLUS E series drives are BDM (Basic Drive Module), as defined in the EN 61800-3. Only a professional assembler, expert in the field of motor drives and in their EMC aspects, can install and put in service this component. R.T.A. has the responsibility to verify the products compatibility in some typical way of use in order to give correct installation information. In any cases, it is responsibility of the professional assembler, who installs this product, to verify the compatibility of the complete machine or system.
- 10.3- The set consisting of drive, motor, transformer and all related cablings are source of electromagnetic interferences. The assembler of installation must consider these problems during the project of the plant where the drive (or drives) will be installed in order to shield and/or reduce these interferences. Tests performed by R.T.A. show that the most effective measures able to reduce these interferences are the following:

- Shielding of cables for the connection between motor and drive. The shield of this cable has to be directly connected to PLUS E series drive terminal 1. This shielding can be avoided only in case of very small and compact machine where motor, drive and related connections are located in the same enclosure, showing adequate shield performance.
- Connect earth line to motor chassis. To reduce the radio-frequency emissions, the mechanical connection of motor to machine chassis (by means of mounting flanges and screws), is typically simple and effective solution. In this case, both screws and chassis must be of conductor material and the chassis must be connected to earth. See Fig. 6.
- Location of motor-drive set in the same cabinet shielded from electromagnetic interferences.
- Use a power supply transformer with a metallic shield, connected to earth, interposed between primary and secondary winding.
- Interpose a filter between the transformer primary and the main (220 or 380 V_{AC}). The filter is used to reduce conducted electromagnetic interferences. Filter characteristics in a specific installation depend on the following factors:
 - The specific standard limits the machine (in which drive is used) is subjected to.
 - Power level of application (voltage and current setting of the drive).
 - Presence of other filtering systems in the general electrical machine connections.

In any case, the following filter types are recommended:

- CORCOM VDK series for single-phase power supply.
- CORCOM FCD10 series for three-phase power supply.

Different types of these series differ for current rating. Choose the specific model according to the power level of the specific installation.

- Consider that the position of the filter in the system is extremely important: no electromagnetic coupling must take place between electromagnetic source and circuits (and lines). To this end, filter and main must be kept as close as possible.
 - All earth connections mentioned above have to be realized with the less possible inductance.
- 10.4- To improve the drive logic input signals immunity from external noise the following well known procedures, to manage the relatively fast signals treatment must be considered:
- Use shielded cables with shield connected to terminal PE (see Fig. 6).
 - Connect the shield of encoder cable to earth screw of the motor with short cable and with minimum inductance.
 - When cables length exceeds 5-6 meters, prefer "buffer" type driving signals instead of "open collector" type.
 - Keep signal cables separate from power cables. In particular keep signal cables separate from motor output cables.
 - Carefully verify logic level compatibility when interfacing drive with control system.



- 10.5- Following these procedures is essential to realize an installation which complies with the requirements of 2004/108/CE directive. The real specific standard compliance have to be proved in the complete installation. In fact the effectiveness of the suggested application notes depends also on machine topology and on the measurement setup. Test performed by R.T.A. simulating typical installations and following the mentioned above indications show that EN 61800-3 standard compliance applications can be achieved.
- 10.6- In some cases, due to the characteristics of particular installations, conflicts between ground connections necessary for shielding purposes and ground connections necessary for safety reasons could arise. Remember that, in such cases, prescriptions regarding safety take priority, but remember also that, in almost all of the cases it is possible to find a solution meeting both prescriptions; R.T.A. is available for further information about these problems.

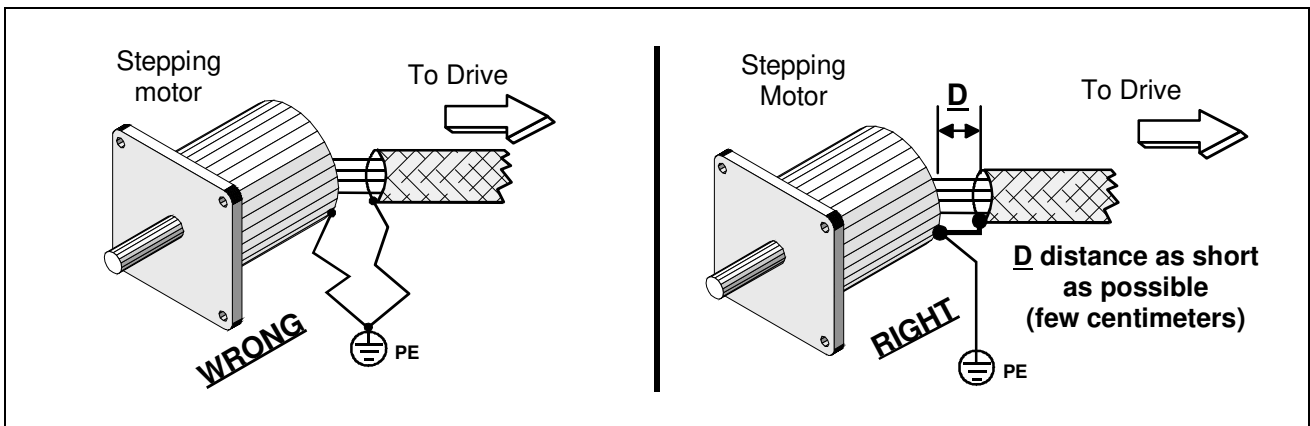

Fig. 13 - Shielded connection at stepping motor side.

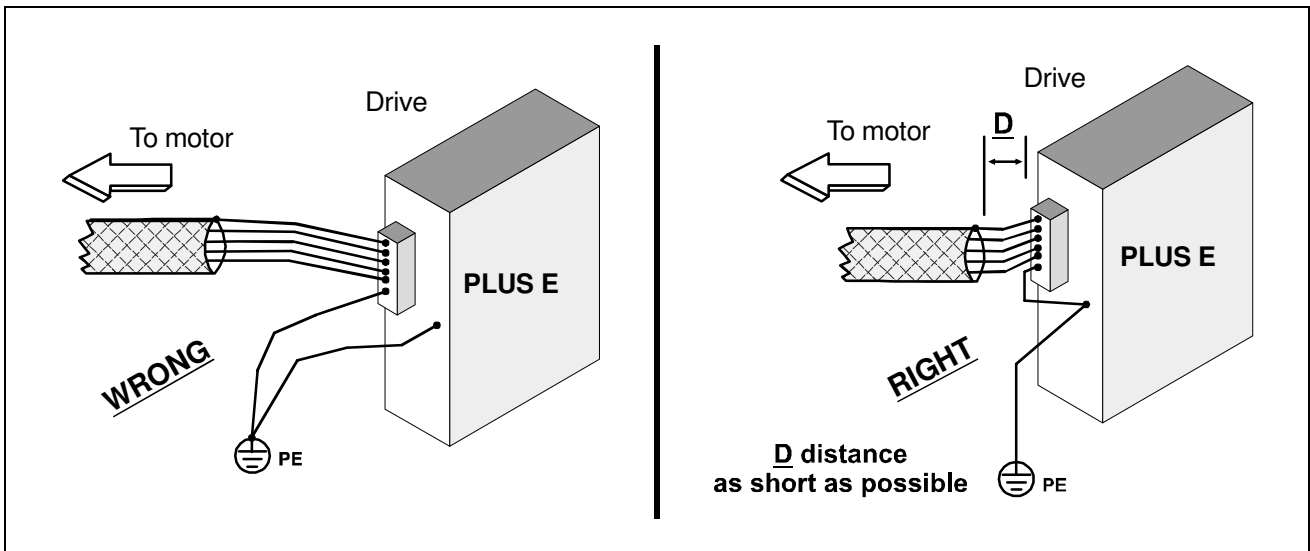

Fig. 14 - Shielded connection at drive side.



11- APPLICATION NOTES

- 11.1- During the normal movement with load the difference between theoretical and real angular position can be close to 3.6° without causing a loss of synchronism. When an ENCODER RESET is performed, the SYNCRONISM LOSS ALARM (13) is reset and the error between theoretical and real position of the motor is set to zero; in this phase, if the motor is not at standstill or if an external torque is the cause of an angle different from zero, such difference will result in an offset in Zero Position affecting the accuracy of the SYNCRONISM LOSS ALARM. We suggest a setting of dip 4 and 5 of DP1 corresponding to 5.4° in order to avoid false alarms.
- 11.2- ENCODER RESET mode can be selected through dip 4 of DP2: AUTOMATIC or MANUAL Mode are possible. In AUTOMATIC Mode the drive automatically performs an Encoder Reset at Power ON and, in case of SYNCRONISM LOSS Alarm, 500 ms after the last step pulse on STEP IN or 500 ms after the motor stop. In MANUAL Mode, Encoder Reset is performed by the user through ENCODER RESET INPUT (18). AUTOMATIC Mode is the standard mode. In particular conditions (as described in 11.1), a careful use of MANUAL Mode can assure higher accuracy of error detection.
- 11.3- The Manual ENCODER RESET has to occur when the motor is energized (CURRENT OFF (16) input HIGH).
- 11.4- In order to have a reliable SYNCRONISM LOSS DETECTION ALARM pay attention to the following points:
- Follow the connection instruction in Table 1 Chap. 5, particularly about the correspondence of motor cable colors
 - Follow the connection instruction in Chap. 4.
 - ENCODER RESET has to be done with the motor at standstill and without force acting on the motor
 - Do not use CURRENT OFF (16) after the ENCODER RESET
- 11.5- The sequence to have a ZERO SEARCH on mechanical limit with good precision (and no vibration) is as follow:
- Set ON dip 3 and 4 of DP2 (ZERO SEARCH mode + MANUAL ENCODER RESET)
 - Use one of following steps per revolution setting: 1600, 3200, 2000, 4000
 - Set OFF dip 4 and 5 of DP1 as for normal SYNCRONISM LOSS DETECTION (encoder sensitivity 5.4°)
 - Set input 17 to ON (ENCODER SENSITIVITY 1.8°).
 - Move in the direction of Mechanical Limit with speed < 40 RPM, reading SYNCRONISM LOSS output (13).
 - When this output goes OFF, stop sending step pulses to STEP IN (14).
 - Run in the opposite direction.
 - Stop and wait for motor standstill.
 - Set OFF input 17 (ENCODER SENSITIVITY 5.4°) and set ON MANUAL RESET (18)
 - Set OFF MANUAL RESET (18); Zero Search is finished – normal operation can start
- 11.6- ZERO SEARCH on mechanical limit operation, as described in the previous point, could cause excessive vibrations and so being not reliable in following cases:
- [Total Inertia on motor shaft] $> 20 \times$ [Motor rotor Inertia]
High elasticity of backlash of the mechanical transmission system.