

SF2C SERIES

Related Information

- General terms and conditions..... F-3
- Selection guide..... P.457~
- Glossary of terms / General precautions...P.1549~ / P.1595
- SF-C13..... P.663~

- FIBER SENSORS
- LASER SENSORS
- PHOTOELECTRIC SENSORS
- MICRO PHOTOELECTRIC SENSORS
- AREA SENSORS
- SAFETY LIGHT CURTAINS / SAFETY COMPONENTS
- PRESSURE / FLOW SENSORS
- INDUCTIVE PROXIMITY SENSORS
- PARTICULAR USE SENSORS
- SENSOR OPTIONS
- SIMPLE WIRE-SAVING UNITS
- WIRE-SAVING SYSTEMS
- MEASUREMENT SENSORS
- STATIC CONTROL DEVICES
- LASER MARKERS
- PLC
- HUMAN MACHINE INTERFACES
- ENERGY MANAGEMENT SOLUTIONS
- FA COMPONENTS
- MACHINE VISION SYSTEMS
- UV CURING SYSTEMS
- Selection Guide
- Safety Light Curtains
- Safety Control Units
- Safety Components
- SF4D
- SF4B/SF4B-G
- SF4B-C
- SF4C
- BSF4-AH80
- SF2B
- SF2C
- Definition of Sensing Heights



Category 2 PLc SIL1

industrial.panasonic.com/ac/e

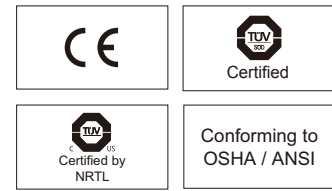

The control category differs depending on the configuration and wiring of the external circuit.

Featuring easy beam axis alignment and reduced wiring

Slim size for efficient applications

Available work space is expanded from the previous model, and productivity is improved.

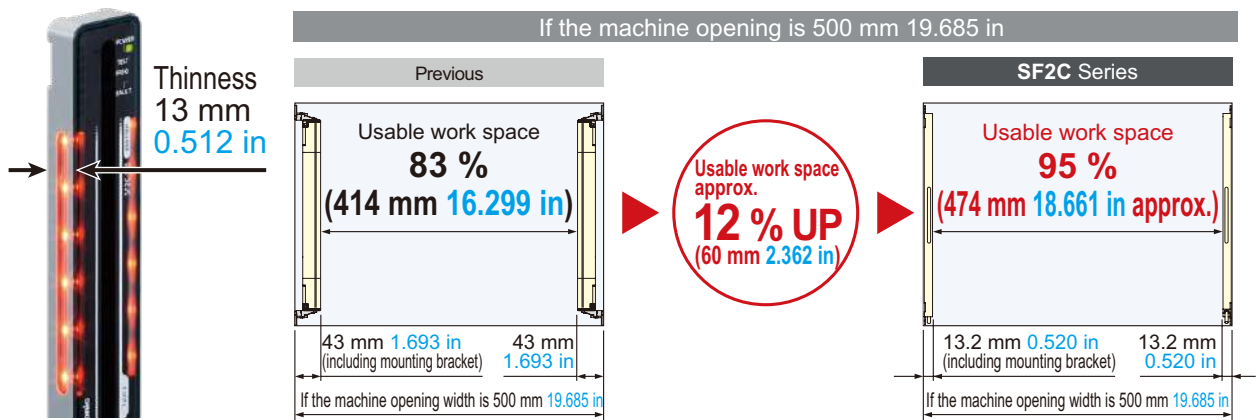

Simple safety distance calculations

Recalculation of the safety distance is unnecessary for each time safety light curtain length is changed.

Safety Distance SF2C-H□ : 128 mm 5.039 in
(Calculation based on ISO 13855)

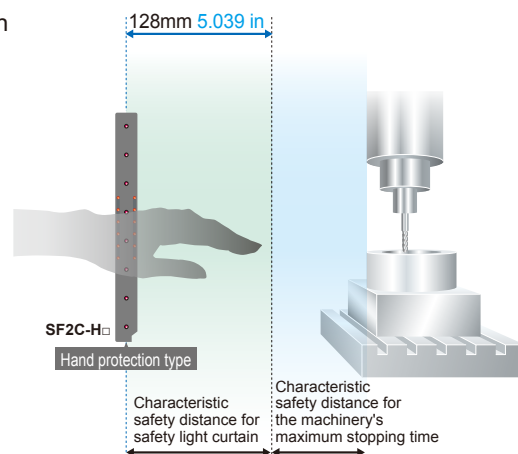

Dramatically less wiring work with optical synchronization

Safety light curtain wiring consists of just five wires each for the emitter and receiver, allowing you to easily implement safety measures in about the same amount of time as with an area sensor with using optical synchronization.

Previous (Type4)

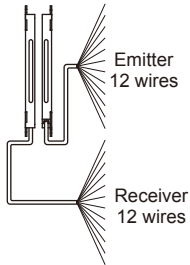

SF2C series (Type2)

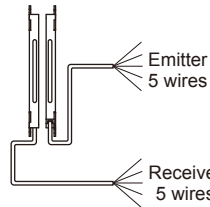

Connection between the emitter and receiver is not required.
Possible to use power supply each.

Functions with just six wires!

- Emitter: +V, 0 V
- Receiver: +V, 0 V, Control output, Lockout output

Beam axis alignment made easy

The emitter has an effective aperture angle of $\pm 5^\circ$ or less for an operating range of 3 m **9.843 ft**. Compared to Type 4 safety light curtains (which have an effective aperture angle of $\pm 2.5^\circ$ or less), the **SF2C** series is easy to align and install.

Easy installation

The standard mounting bracket is already mounted for easy installation.

Can be used in a variety of applications for simplified equipment [Large multi-purpose indicator]

The bright LED indicators located in the center of both sides of each safety light curtain can be light on / blink in orange with external inputs. There is no need for setting up a separate indicator, so that equipment is consolidated.

Applications

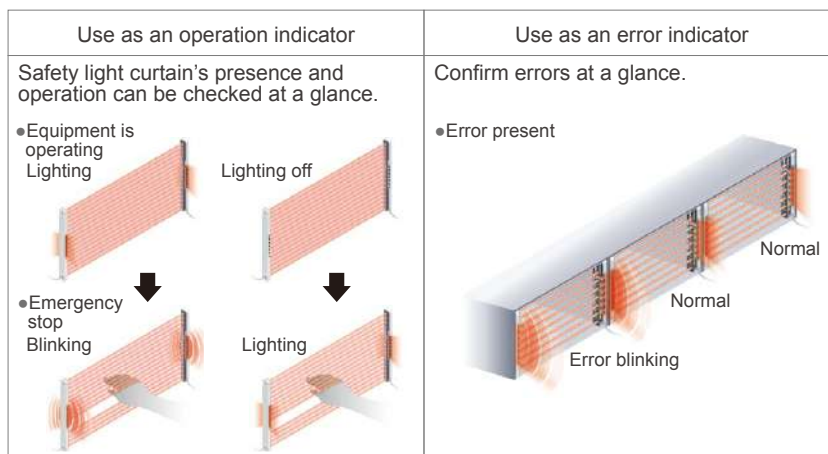

Light weight!

The **SF2C** series is made of resin that is lighter than the conventional aluminum case type*.

Its lightweight body eases the burden on the mounting surface of the equipment and contributes to overall reduced weight during equipment transportation or overseas shipment.

*Except the cable part

Protection structure IP67

An IP67 (IEC) rating is achieved even in an ultra-slim resin body using a laser welding method.

A fast response time for all models

SF2C-H□: 20 ms

The **SF2C** series reduces the safety distance as well as the calculation work required for the safety distance among models with different beam channels.

Material suitable for manufacturing a secondary battery

SF2C body is made of resin and the mounting bracket is made of Stainless Steel (SUS), so materials used are limited. Suitable for manufacturing secondary batteries or for food production equipment.

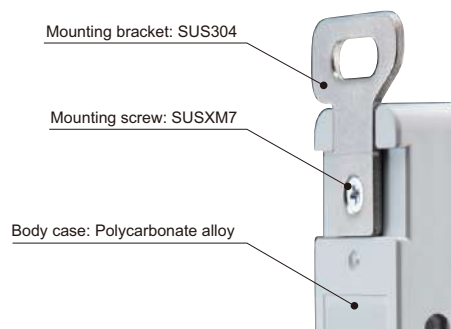

FIBER
SENSORS

LASER
SENSORS

PHOTOELECTRIC
SENSORS

MICRO
PHOTOELECTRIC
SENSORS

AREA
SENSORS

SAFETY LIGHT
CURTAINS /
SAFETY COMPONENTS

PRESSURE /
FLOW
SENSORS

INDUCTIVE
PROXIMITY
SENSORS

PARTICULAR
USE SENSORS

SENSOR
OPTIONS

SIMPLE
WIRE-SAVING
UNITS

WIRE-SAVING
SYSTEMS

MEASUREMENT
SENSORS

STATIC
CONTROL
DEVICES

LASER
MARKERS

PLC

HUMAN MACHINE
INTERFACES

ENERGY
MANAGEMENT
SOLUTIONS

FA COMPONENTS

MACHINE VISION
SYSTEMS

UV CURING
SYSTEMS

Selection
Guide

Safety Light
Curtains

Safety
Control Units

Safety
Components

SF4D

**SF4B/
SF4B-G**

SF4B-C

SF4C

BSF4-AH80

SF2B

SF2C

Definition of
Sensing Heights

PRODUCT CONFIGURATION (RECOMMENDED)

Cable type [Mounting bracket, with 3 m (9.843 ft) cable]

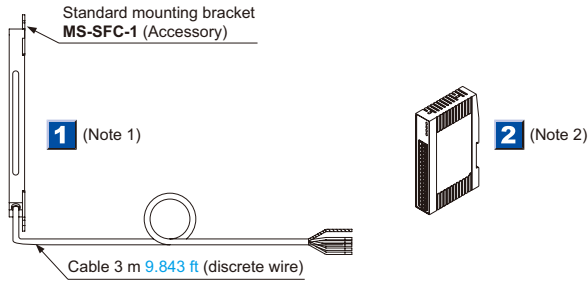

Notes: 1) The SF2C series does not incorporate the external device monitoring function.
 2) Requires a safety circuit architecture that complies with the desired control category implemented using either an SF-C13 Control Unit, a safety relay (p.634), or other equipment.

ORDER GUIDE

1 Safety light curtains

Type	Appearance	Operating range (Note 1)	Model No. (Note 2)		Number of beam channels	Protective height (mm in)
			PNP output type	NPN output type		
Hand protection type Min. sensing object ø25 mm ø0.984 in (20 mm 0.787 in beam pitch)		0.1 to 3m 0.328 to 9.843 in	SF2C-H8-P	SF2C-H8-N	8	160 6.299
			SF2C-H12-P	SF2C-H12-N	12	240 9.449
			SF2C-H16-P	SF2C-H16-N	16	320 12.598
			SF2C-H20-P	SF2C-H20-N	20	400 15.748
			SF2C-H24-P	SF2C-H24-N	24	480 18.898
			SF2C-H28-P	SF2C-H28-N	28	560 22.047
			SF2C-H32-P	SF2C-H32-N	32	640 25.197

Notes: 1) The operating range is the possible setting distance between the emitter and the receiver.

2) The model No. with suffix "E" shown on the label affixed to the product is the emitter, "D" shown on the label is the receiver.

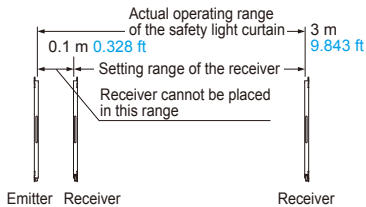

Standard mounting bracket

• MS-SFC-1

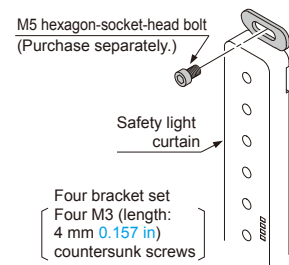

<Mountable in three directions>

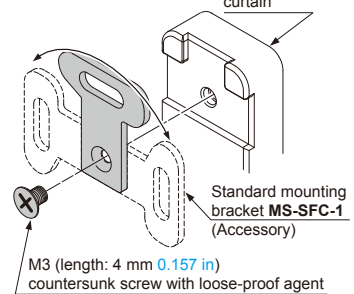

Spare parts (Accessories for safety light curtain)

Designation	Model No.	Description
Standard mounting bracket	MS-SFC-1	Allows the safety light curtain to be mounted at the rear with one M5 hexagon-socket-head bolt. Mounting direction of the bracket can be selected between vertical or horizontal (no dead zone). (4 pcs. per set for emitter and receiver)(Note)
Test rod ø25	SF4C-TR25	Min. sensing object for regular checking. (ø25 mm ø0.984 in)

Note: The body of the safety light curtain is made of resin, so please take into account the expansion and contraction of the longitudinal dimension. When machining mounting holes, please check the actual product.

2 Control unit

Designation	Appearance	Model No.	Description
Slim type control unit		SF-C13	Use a discrete wire cable to connect to the safety light curtain. Relay output. Compatible with up to Control Category 2 when used together with SF2C series.

FIBER SENSORS
 LASER SENSORS
 PHOTO-ELECTRIC SENSORS
 MICRO PHOTO-ELECTRIC SENSORS
 AREA SENSORS
 SAFETY LIGHT CURTAINS/ SAFETY COMPONENTS
 PRESSURE / FLOW SENSORS
 INDUCTIVE PROXIMITY SENSORS
 PARTICULAR USE SENSORS
 SENSOR OPTIONS
 SIMPLE WIRE-SAVING UNITS
 WIRE-SAVING SYSTEMS
 MEASUREMENT SENSORS
 STATIC CONTROL DEVICES
 LASER MARKERS
 PLC
 HUMAN MACHINE INTERFACES
 ENERGY MANAGEMENT SOLUTIONS
 FA COMPONENTS
 MACHINE VISION SYSTEMS
 UV CURING SYSTEMS
 Selection Guide
 Safety Light Curtains
 Safety Control Units
 Safety Components
SF4D
SF4B/ SF4B-G
SF4B-C
SF4C
BSF4-AH80
SF2B
SF2C
 Definition of Sensing Heights

OPTIONS

Mounting brackets

Designation	Model No.	Description
NA2-N compatible mounting bracket	MS-SFC-2	Used when changing over area sensor NA2-N series to the SF2C series. The mounting holes of NA2-N series can continue to be used. Center mounting by a M6 hexagon-socket-head bolt is also possible. (4 pcs. per set for emitter and receiver)(Note)
Versatile bracket	MS-SFC-3	Two ways of mounting are possible. ① Rear mounting which enables beam adjustment ② Dead zoneless center mounting on aluminum frame (4 pcs. per set for emitter and receiver)(Note)
Intermediate supporting bracket for versatile bracket	MS-SFC-4	Used to support the safety light curtain in the middle. Be sure to purchase it when using MS-SFC-3 on SF2C-H28-P , SF2C-H28-N , SF2C-H32-P , SF2C-H32-N . (2 pcs. per set for emitter and receiver)(Note)

Note: The body of the safety light curtain is made of resin, so please take into account the expansion and contraction of the longitudinal dimension. When machining mounting holes, please check the actual product.

NA2-N compatible mounting bracket

• **MS-SFC-2**

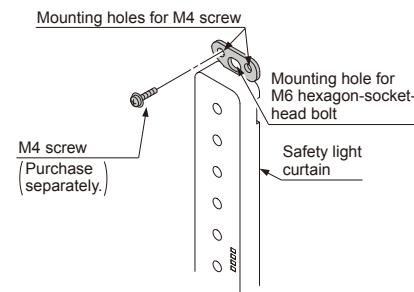

Versatile bracket

• **MS-SFC-3**

<Rear mounting>

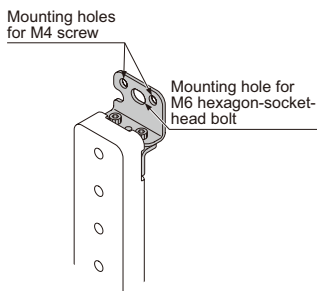

<Dead zoneless mounting>

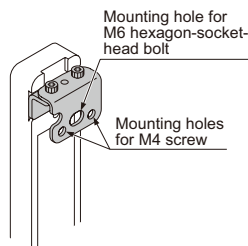

Intermediate supporting bracket for versatile bracket

• **MS-SFC-4**

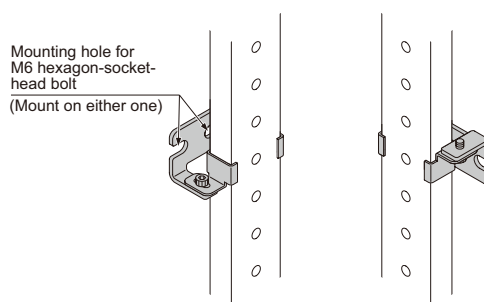

Metal protection case

• **MS-SFCH-8** • **MS-SFCH-12/16/20/24/28/32**

Applicable beam channels	Designation	Metal protection case (2 pcs. per set for emitter and receiver)
SF2C-H□		Model No.
8		MS-SFCH-8
12		MS-SFCH-12
16		MS-SFCH-16
20		MS-SFCH-20
24		MS-SFCH-24
28		MS-SFCH-28
32		MS-SFCH-32



• **Recommended safety relay**

Panasonic Corporation SF relay, slim type

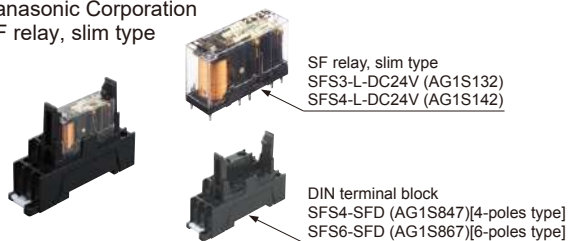

Note: Contact Panasonic Corporation for details on the recommended products.

Type	With LED indicator		
Model No.	SFS3-L-DC24V	SFS4-L-DC24V	
Item	Part No.	AG1S132	AG1S142
Contact arrangement	3a1b	4a2b	
Rated nominal switching capacity	6 A / 250 V AC, 6 A / 30 V DC		
Min. switching capacity	1 mA / 5 V DC		
Coil rating	15 mA / 24 V DC	20.8 mA / 24 V DC	
Rated power consumption	360 mW	500 mW	
Operation time	20 ms or less		
Release time	20 ms or less		
Ambient temperature	-40 to +85 °C -40 to +185 °F (Humidity: 5 to 85 % RH)		
Applicable standards	UL/c-UL, TÜV, Korea's S-mark		

FIBER SENSORS

LASER SENSORS

PHOTO-ELECTRIC SENSORS

MICRO PHOTO-ELECTRIC SENSORS

AREA SENSORS

SAFETY LIGHT CURTAINS / SAFETY COMPONENTS

PRESSURE / FLOW SENSORS

INDUCTIVE PROXIMITY SENSORS

PARTICULAR USE SENSORS

SENSOR OPTIONS

SIMPLE WIRE-SAVING UNITS

WIRE-SAVING SYSTEMS

MEASUREMENT SENSORS

STATIC CONTROL DEVICES

LASER MARKERS

PLC

HUMAN MACHINE INTERFACES

ENERGY MANAGEMENT SOLUTIONS

FA COMPONENTS

MACHINE VISION SYSTEMS

UV CURING SYSTEMS

Selection Guide

Safety Light Curtains

Safety Control Units

Safety Components

SF4D

SF4B/ SF4B-G

SF4B-C

SF4C

BSF4-AH80

SF2B

SF2C

Definition of Sensing Heights

SPECIFICATIONS

Safety light curtain common specifications

Type	PNP output type	NPN output type
Model No.	SF2C-H□-P	SF2C-H□-N
Applicable standards	IEC 61496-1/2 (Type 2), ISO 13849-1 (Category 2, PLc), IEC 61508-1 to 7 (SIL 1)	
International standard	IEC 61496-1/2 (Type 2), ISO 13849-1 (Category 2, PLc), IEC 61508-1 to 7 (SIL 1)	
Japan	JIS B 9704-1/2 (Type 2), JIS B 9705-1 (Category 2), JIS C 0508 (SIL 1)	
Europe (EU) (Note 2)	EN 61496-1 (Type 2), EN ISO 13849-1 (Category 2, PLc), EN 61508-1 to 7 (SIL 1), EN 55011, EN 50178, EN 61000-6-2	
North America (Note 3)	ANSI/UL 61496-1/2 (Type 2), ANSI/UL 508, CAN/CSA 61496-1/2 (Type 2), CAN/CSA C22.2 No.14, ANSI/RIA 15.06	
Regulatory compliance	CE Marking (Machinery Directive, EMC Directive, RoHS Directive), TÜV SÜD certification, TÜV SÜD NRTL certification	
Operating range	0.1 to 3 m 0.328 to 9.843 ft	
Beam pitch	20 mm 0.787 in	
Min. sensing object	ø25 mm ø0.984 in opaque object	
Effective aperture angle	±5° or less [for an operating range exceeding 3 m 9.843 ft (conforming to IEC 61496-2 / ANSI/UL 61496-2)]	
Supply voltage	24 V DC ± 20 % Ripple P-P 10 % or less	
Control output (OSSD)	<ul style="list-style-type: none"> • Max. source current: 200 mA • Applied voltage: same as supply voltage (between the control output and +V) • Residual voltage: 2.5 V or less (source current 200 mA, when using 10 m 32.808 ft length cable) • Leakage current: 200 µA or less (including power supply OFF condition) • Max. load capacity: 2.2 µF (No load to Max. source current) • Load wiring resistance: 3 Ω or less 	<ul style="list-style-type: none"> • Max. sink current: 200 mA • Applied voltage: same as supply voltage (between the control output and 0 V) • Residual voltage: 2.5 V or less (sink current 200 mA, when using 10 m 32.808 ft length cable) • Leakage current: 200 µA or less (including power supply OFF condition) • Max. load capacity: 2.2 µF (No load to Max. sink current) • Load wiring resistance: 3 Ω or less
Operation mode	ON when all beam channels are received, OFF when one or more beam channels are interrupted (OFF also in case of any malfunction in the safety light curtain or the synchronization signal)	
Protection circuit	Incorporated	
Response time	OFF response: 20 ms or less, ON response: 80 to 100 ms	
Lockout output (SSD)	<ul style="list-style-type: none"> • Max. source current: 60 mA • Applied voltage: same as supply voltage (between the lockout output and +V) • Residual voltage: 2.5 V or less (source current 60 mA, when using 10 m 32.808 ft length cable) • Leakage current: 200 µA or less (including power supply OFF condition) • Max. load capacity: 2.2 µF (No load to Max. source current) • Load wiring resistance: 3 Ω or less 	<ul style="list-style-type: none"> • Max. sink current: 60 mA • Applied voltage: same as supply voltage (between the lockout output and 0 V) • Residual voltage: 2.5 V or less (sink current 60 mA, when using 10 m 32.808 ft length cable) • Leakage current: 200 µA or less (including power supply OFF condition) • Max. load capacity: 2.2 µF (No load to Max. sink current) • Load wiring resistance: 3 Ω or less
Operation mode	ON during normal operation, OFF during lockout (Note 4)	
Protection circuit	Incorporated	
Interference prevention function	Incorporated	
Test input function	Incorporated	
Large display unit function	Incorporated	
Pollution degree / Operating altitude	3 / 2,000 m 6561.680 ft or less (Note 5)	
Degree of protection	IP65, IP67(IEC)	
Ambient temperature	-10 to +55 °C +14 to +131 °F (No dew condensation or icing allowed), Storage: -25 to +60 °C -13 to +140 °F	
Ambient humidity	30 to 85 % RH, Storage: 30 to 85 % RH	
Ambient illuminance	Incandescent light: 5,000 lx or less at the light-receiving face	
Dielectric strength voltage	1,000 V AC for one min. between all supply terminals connected together and enclosure	
Insulation resistance	20 MΩ, or more, with 500 V DC megger between all supply terminals connected together and enclosure	
Vibration resistance	10 to 55 Hz frequency, 0.75 mm 0.030 in double amplitude in X, Y and Z directions for two hours each	
Shock resistance	300 m/s ² acceleration (30 G approx.) in X, Y and Z directions three times each	
Emitting element	Infrared LED (Peak emission wavelength: 850 nm 0.034 mil)	
Cable	0.16 mm ² 5-core heat-resistant PVC cable, 3 m 9.842 ft long	
Cable extension	Extension up to 50 m 164.042 ft is possible for both emitter and receiver, with 0.3 mm ² or more cable	
Material	Enclosure: Polycarbonate alloy, Sensing surface: Polycarbonate alloy, MS-SFC-1 (Standard mounting bracket) : Stainless steel (SUS)	
Accessories	MS-SFC-1 (Standard mounting bracket): 1 set, SF4C-TR25 (Test rod): 1 No.	

Notes: 1) Where measurement conditions have not been specified precisely, the conditions used were an ambient temperature of +20 °C **+68 °F**.

2) Regarding EU Machinery Directive, a Notified Body, TÜV SÜD, has certified with the type examination certificate.

3) With regards to the standards in the US, under the US regulation 29 CFR 1910.7, TÜV SÜD America, a Nationally Recognized Testing Laboratory (NRTL) certified by OSHA, has certified with the safety certificate based on UL/ANSI standards.

With regards to the standards in Canada, under the safety regulations based on CEC (Canadian Electric Code), TÜV SÜD America, a Certification Body accredited by SCC, has certified with the safety certificate based on CSA standards.

4) If the emitter enters a lockout state, and light from the emitter enters the receiver, lockout information will be transmitted and lockout output (SSD) will turn OFF.

5) Do not use or store in an environment pressurized to atmospheric pressure or higher at an altitude of 0 m.

SPECIFICATIONS

Safety light curtain individual specifications

Item	Model No.	Type	Min. sensing object $\varnothing 25$ mm $\varnothing 0.984$ in (20 mm 0.787 in beam pitch)						
		PNP output type	SF2C-H8-P	SF2C-H12-P	SF2C-H16-P	SF2C-H20-P	SF2C-H24-P	SF2C-H28-P	SF2C-H32-P
		NPN output type	SF2C-H8-N	SF2C-H12-N	SF2C-H16-N	SF2C-H20-N	SF2C-H24-N	SF2C-H28-N	SF2C-H32-N
Number of beam channels			8	12	16	20	24	28	32
Protective height			160 mm 6.299 in	240 mm 9.449 in	320 mm 12.598 in	400 mm 15.748 in	480 mm 18.898 in	560 mm 22.047 in	640 mm 25.197 in
Current consumption	Large multi-purpose indicator lights off		Emitter: 25 mA or less Receiver: 25 mA or less	Emitter: 30 mA or less Receiver: 30 mA or less		Emitter: 35 mA or less Receiver: 35 mA or less			
	Large multi-purpose indicator lights up		Emitter: 35 mA or less Receiver: 30 mA or less	Emitter: 35 mA or less Receiver: 35 mA or less	Emitter: 40 mA or less Receiver: 35 mA or less	Emitter: 40 mA or less Receiver: 40 mA or less	Emitter: 45 mA or less Receiver: 40 mA or less	Emitter: 45 mA or less Receiver: 45 mA or less	Emitter: 50 mA or less Receiver: 45 mA or less
PFH _D	PNP output type		3.60×10^{-9}	3.66×10^{-9}	3.73×10^{-9}	3.79×10^{-9}	3.85×10^{-9}	3.92×10^{-9}	3.98×10^{-9}
	NPN output type		3.74×10^{-9}	3.80×10^{-9}	3.86×10^{-9}	3.93×10^{-9}	3.99×10^{-9}	4.05×10^{-9}	4.12×10^{-9}
MTTF _D			100 years or more						
Net weight (Total of emitter and receiver)			280 g approx.	340 g approx.	400 g approx.	460 g approx.	520 g approx.	580 g approx.	640 g approx.

Note: Where measurement conditions have not been specified precisely, the conditions used were an ambient temperature of +20 °C +68 °F.
PFH_D: Probability of dangerous failure per hour, MTTF_D: Mean time to dangerous failure (in years)

Control unit

Item	Model No.	SF-C13
Connectable safety light curtains	Safety light curtain manufactured by Panasonic Industrial Devices SUNX	
Applicable standards	EN 61496-1 (Type 4), EN 55011, EN ISO 13849-1 (Category 4, PLe), IEC 61496-1 (Type 4), ISO 13849-1 (Category 4, PLe), JIS B 9704-1 (Type 4), JIS B 9705-1 (Category 4), ANSI/UL 61496-1 (Type 4), UL 1998 (Class 2)	
Regulatory compliance	CE Marking (Machinery Directive, Low Voltage Directive, EMC Directive, RoHS Directive), UL/c-UL Listing certification, TÜV SÜD certification, S-mark certification	
Control category	ISO 13849-1 (EN ISO 13849-1, JIS B 9705-1) compliance up to Category 4, PLe standards	
Supply voltage / Current consumption	24 V DC ± 10 % Ripple P-P 10 % or less / 100 mA or less (without safety light curtain)	
Fuse (power supply)	Built-in electronic fuse, Triggering current: 0.5 A or more, Reset after power down	
Safety output	NO contact $\times 3$ (13-14, 23-24, 33-34)	
Application category	AC-15, DC-13 (IEC 60947-5-1)	
Rated operation voltage (U _e) / Rated operation current (I _e)	30 V DC / 4 A, 230 V AC / 4 A, resistive load (For inductive load, during contact protection). Min applicable load: 10 mA (at 24 V DC) (Note 2)	
Contact resistance	100 m Ω or less (initial value)	
Contact protection fuse rated	4 A (slow blow)	
Pick-up delay (Auto reset / Manual reset)	80 ms or less / 90 ms or less	
Response time (Recovery time)	10 ms or less	
Auxiliary output	Safety relay contact (NC contact) $\times 1$ (41-42) (Related to safety output)	
Rated operation voltage / current	24 V DC / 2 A, Min. applicable load: 10 mA (at 24 V DC)	
Contact protection fuse rated	2 A (slow blow)	
Semiconductor auxiliary output (AUX)	PNP open-collector transistor • Max. source current: 60 mA	
Output operation	On when the safety light curtain is interrupted	
Excess voltage category	II	
Polarity selection function	Incorporated (Cable connection allows selection of plus/minus ground) Minus ground: Correspond to PNP output safety light curtain Plus ground: Correspond to NPN output safety light curtain	
Pollution degree	2	
Protection	Enclosure: IP40, Terminal: IP20	
Ambient temperature	-10 to +55 °C +14 to +131 °F (No dew condensation or icing allowed), Storage: -25 to +70 °C -13 to +158 °F	
Vibration resistance	10 to 55 Hz frequency, 0.35 mm 0.014 in amplitude in X, Y and Z directions for twenty times each	
Enclosure material	ABS	
Weight	Net weight: 200 g approx.	

Notes: 1) Where measurement conditions have not been specified precisely, the conditions used were an ambient temperature of +20 °C +68 °F

2) If several **SF-C13** units are being used in line together, leave a space of 5 mm 0.197 in or more between each unit. If the units are touching each other, reduce the rated operating current for safety output in accordance with the ambient operating temperature as shown in the graphs at right.

3) Refer to p.667 for details of the specifications for **SF-C13**.

⌋ Dilating when SF-C13 units are mounted close together ⌋

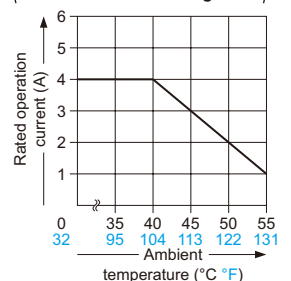

FIBER SENSORS

LASER SENSORS

PHOTO-ELECTRIC SENSORS

MICRO PHOTO-ELECTRIC SENSORS

AREA SENSORS

SAFETY LIGHT CURTAINS / SAFETY COMPONENTS

PRESSURE / FLOW SENSORS

INDUCTIVE PROXIMITY SENSORS

PARTICULAR USE SENSORS

SENSOR OPTIONS

SIMPLE WIRE-SAVING UNITS

WIRE-SAVING SYSTEMS

MEASUREMENT SENSORS

STATIC CONTROL DEVICES

LASER MARKERS

PLC

HUMAN MACHINE INTERFACES

ENERGY MANAGEMENT SOLUTIONS

FA COMPONENTS

MACHINE VISION SYSTEMS

UV CURING SYSTEMS

Selection Guide

Safety Light Curtains

Safety Control Units

Safety Components

SF4D**SF4B/ SF4B-G****SF4B-C****SF4C****SF4-AH80****SF2B****SF2C**

Definition of Sensing Heights

- FIBER SENSORS
- LASER SENSORS
- PHOTO-ELECTRIC SENSORS
- MICRO PHOTO-ELECTRIC SENSORS
- AREA SENSORS
- SAFETY LIGHT CURTAINS / SAFETY COMPONENTS**
- PRESSURE / FLOW SENSORS
- INDUCTIVE PROXIMITY SENSORS
- PARTICULAR USE SENSORS
- SENSOR OPTIONS
- SIMPLE WIRE-SAVING UNITS
- WIRE-SAVING SYSTEMS
- MEASUREMENT SENSORS
- STATIC CONTROL DEVICES
- LASER MARKERS
- PLC
- HUMAN MACHINE INTERFACES
- ENERGY MANAGEMENT SOLUTIONS
- FA COMPONENTS
- MACHINE VISION SYSTEMS
- UV CURING SYSTEMS
- Selection Guide
- Safety Light Curtains
- Safety Control Units
- Safety Components

I/O CIRCUIT AND WIRING DIAGRAMS

PNP output type

I/O circuit diagram

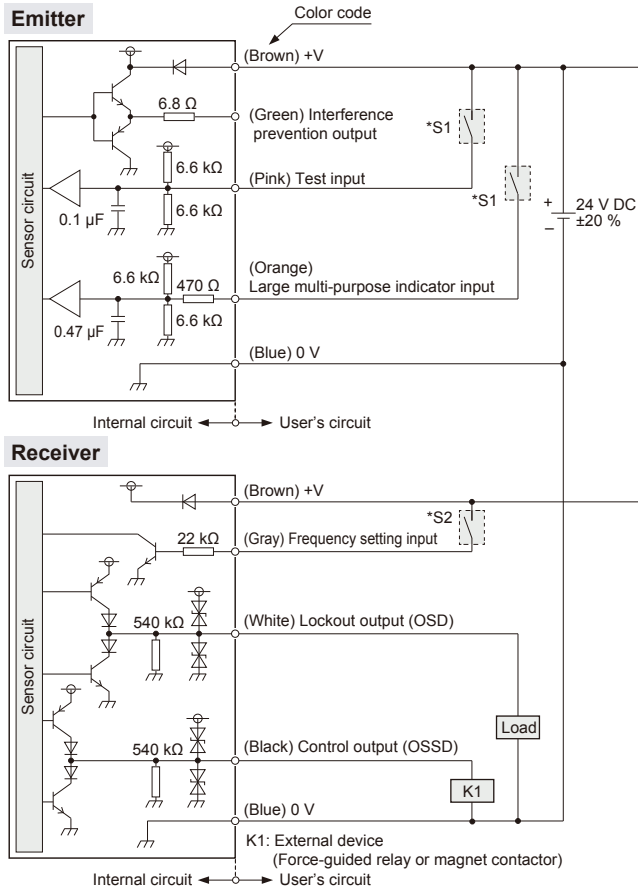

* S1,S2

<p>Switch S1</p> <ul style="list-style-type: none"> • Test input / Large multi-purpose indicator input ON : $V_s - 2.5$ V to V_s OFF : Open <p>Switch S2</p> <ul style="list-style-type: none"> • Frequency setting input Frequency 1 setting: Open Frequency 2 setting: +V

Notes: 1) If the large multi-purpose indicator input wiring (Orange) is connected to +V, the orange LED lights on. When they are disconnected, the orange LED lights off.
2) V_s is the applying supply voltage.

NPN output type

I/O circuit diagram

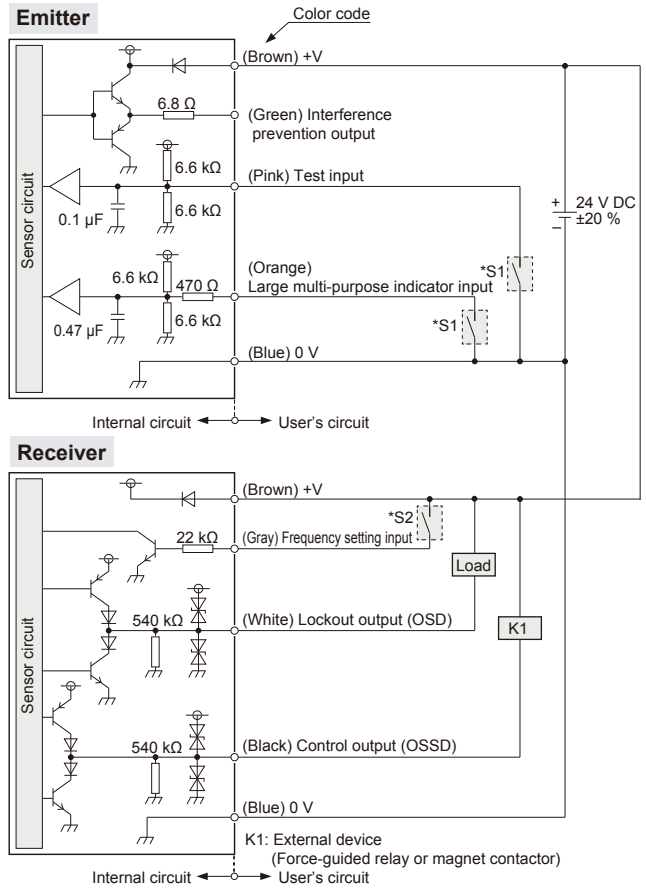

* S1,S2

<p>Switch S1</p> <ul style="list-style-type: none"> • Test input / Large multi-purpose indicator input ON : 0 to +2.5 V OFF : Open <p>Switch S2</p> <ul style="list-style-type: none"> • Frequency setting input Frequency 1 setting: Open Frequency 2 setting: +V
--

Note: If the large multi-purpose indicator input wiring (Orange) is connected to 0 V, the orange LED lights on. When they are disconnected, the orange LED lights off.

SF4D

SF4B/
SF4B-G

SF4B-C

SF4C

BSF4-AH80

SF2B

SF2C

Definition of
Sensing Heights

I/O CIRCUIT AND WIRING DIAGRAMS

Connection example

Basic wiring: Min. operation only

This is the general configuration using one set of the emitter and receiver facing each other. The control output (OSSD) turns OFF if the light is interrupted, while it automatically turns ON if receive the light.

<PNP output type SF2C-H□-P>

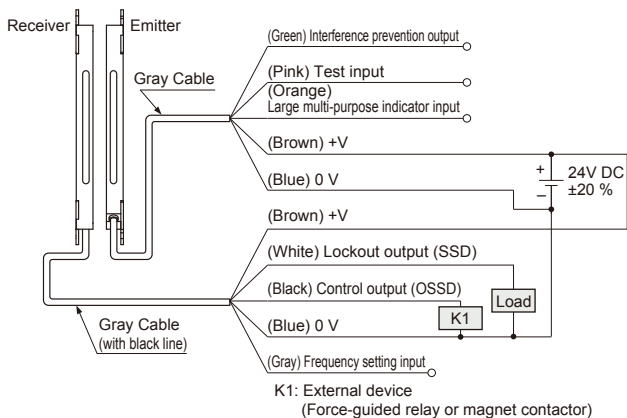

<NPN output type SF2C-H□-N>

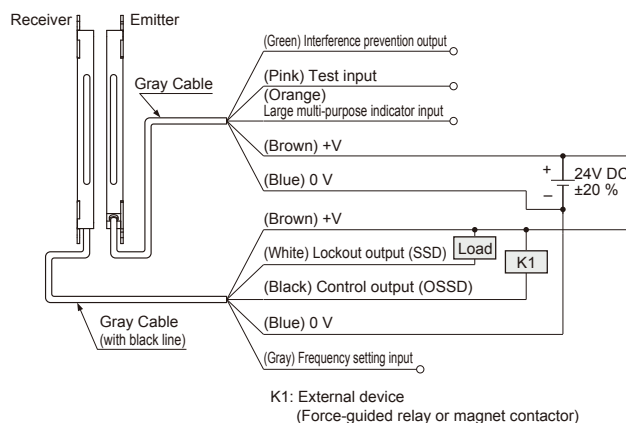

Wiring in case of using test input / large multi-purpose indicator / interference prevention functions

<PNP output type SF2C-H□-P>

Frequency 1 safety light curtain

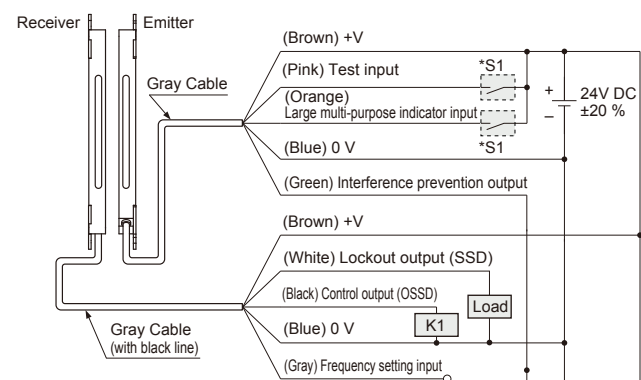

Frequency 2 safety light curtain

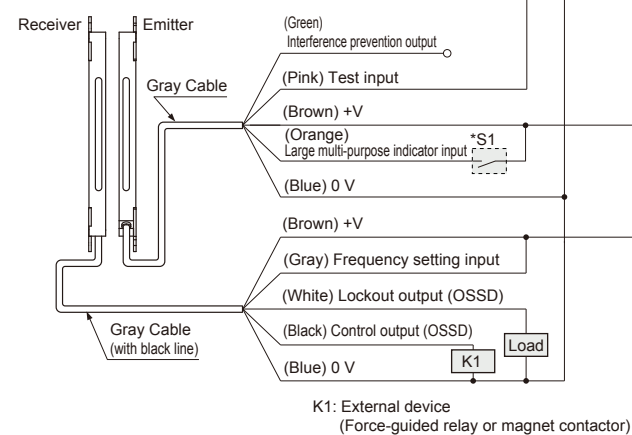

* S1

<Frequency setting input>

Switch S1
ON: Vs -2.5 V to Vs
OFF: Open

Frequency 1 setting: Open
Frequency 2 setting: +V

Notes: 1) If the large multi-purpose indicator input wiring (Orange) is connected to +V, the orange LED lights on. When they are disconnected, the orange LED lights off.

2) Vs is the applying supply voltage.

<NPN output type SF2C-H□-N>

Frequency 1 safety light curtain

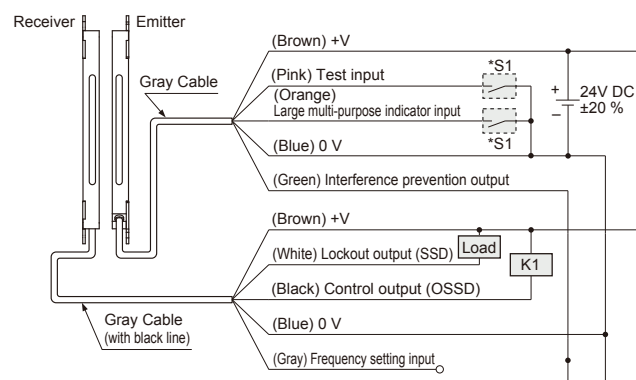

Frequency 2 safety light curtain

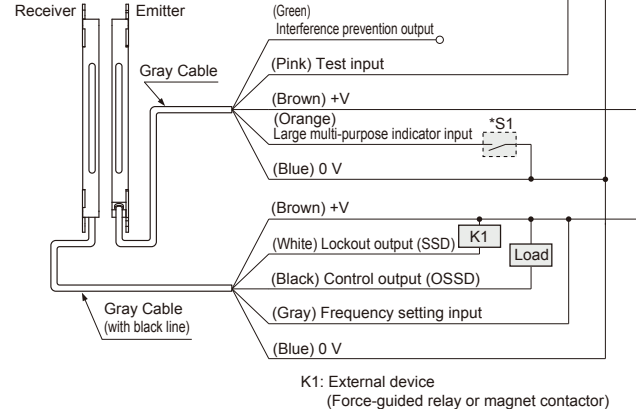

* S1

<Frequency setting input>

Switch S1
ON: 0 to +2.5 V
OFF: Open

Frequency 1 setting: Open
Frequency 2 setting: +V

Note: If the large multi-purpose indicator input wiring (Orange) is connected to 0 V, the orange LED lights on. When they are disconnected, the orange LED lights off.

FIBER SENSORS

LASER SENSORS

PHOTO-ELECTRIC SENSORS

MICRO PHOTO-ELECTRIC SENSORS

AREA SENSORS

SAFETY LIGHT CURTAINS / SAFETY COMPONENTS

PRESSURE / FLOW SENSORS

INDUCTIVE PROXIMITY SENSORS

PARTICULAR USE SENSORS

SENSOR OPTIONS

SIMPLE WIRE-SAVING UNITS

WIRE-SAVING SYSTEMS

MEASUREMENT SENSORS

STATIC CONTROL DEVICES

LASER MARKERS

PLC

HUMAN MACHINE INTERFACES

ENERGY MANAGEMENT SOLUTIONS

FA COMPONENTS

MACHINE VISION SYSTEMS

UV CURING SYSTEMS

Selection Guide

Safety Light Curtains

Safety Control Units

Safety Components

SF4D

SF4B/ SF4B-G

SF4B-C

SF4C

BSF4-AH80

SF2B

SF2C

Definition of Sensing Heights

- FIBER SENSORS
- LASER SENSORS
- PHOTO-ELECTRIC SENSORS
- MICRO PHOTO-ELECTRIC SENSORS
- AREA SENSORS
- SAFETY LIGHT CURTAINS / SAFETY COMPONENTS**
- PRESSURE / FLOW SENSORS
- INDUCTIVE PROXIMITY SENSORS
- PARTICULAR USE SENSORS
- SENSOR OPTIONS
- SIMPLE WIRE-SAVING UNITS
- WIRE-SAVING SYSTEMS
- MEASUREMENT SENSORS
- STATIC CONTROL DEVICES
- LASER MARKERS
- PLC
- HUMAN MACHINE INTERFACES
- ENERGY MANAGEMENT SOLUTIONS
- FA COMPONENTS
- MACHINE VISION SYSTEMS
- UV CURING SYSTEMS
- Selection Guide
- Safety Light Curtains
- Safety Control Units
- Safety Components
- SF4D**
- SF4B/ SF4B-G**
- SF4B-C**
- SF4C**
- BSF4-AH80
- SF2B**
- SF2C**
- Definition of Sensing Heights

I/O CIRCUIT AND WIRING DIAGRAMS

Control unit SF-C13 wiring diagram (Control category 2)

PNP output type: Min. operation only

Connect the safety light curtain control output OSSD to S1 and make a short-circuit between S2 and S3.

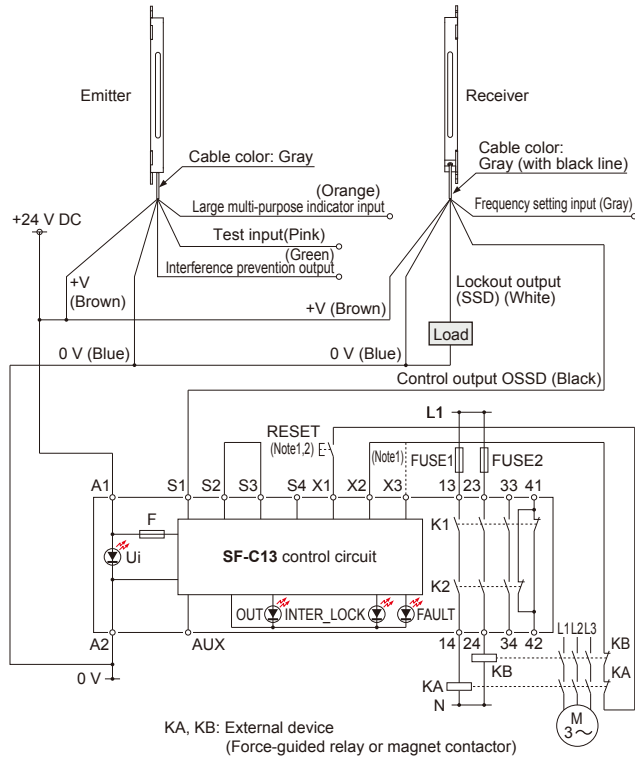

Terminal arrangement diagram

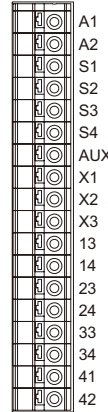

Terminal	Function
A1	+24 V DC
A2	0 V
S1 to S4	Safety light curtain control output (OSSD) input terminal
AUX	Semiconductor auxiliary output
X1	Reset output terminal
X2	Reset input terminal (Manual)
X3	Reset input terminal (Automatic)
13-14, 23-24, 33-34	Safety output (NO contact × 3)
41-42	Auxiliary output (NC contact × 1)

A terminal block is required for wiring of safety light curtain side.

- Notes: 1) The left diagram is when using manual reset. If automatic reset is used, disconnect the lead from X2 and connect it to X3. In this case, a reset (RESET) button is not needed.
 2) Use a momentary-type switch as the reset (RESET) button.

NPN output type: Min. operation only

Connect the safety light curtain control output OSSD to S4 and make a short-circuit between S2 and S3.

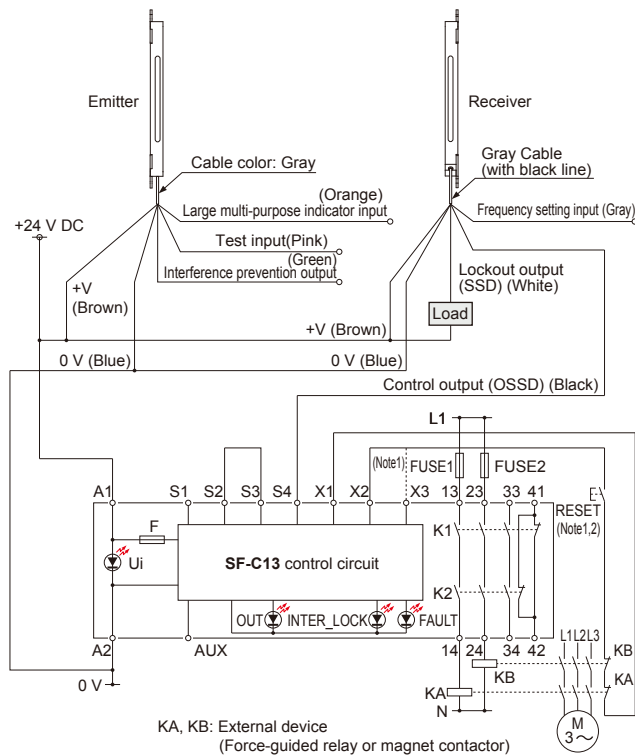

- Notes: 1) The left diagram is when using manual reset. If automatic reset is used, disconnect the lead from X2 and connect it to X3. In this case, a reset (RESET) button is not needed.
 2) Use a momentary-type switch as the reset (RESET) button.

PRECAUTIONS FOR PROPER USE

Refer to the instruction manual for details.
The instruction manual can be downloaded from our website.



- When this device is used in the “PSDI mode”, an appropriate control circuit must be configured between this device and the machinery. For details, be sure to refer to the standards or regulations applicable in each region or country.





- This catalog is a guide to select a suitable product. Be sure to read instruction manual prior to its use.
- Both emitter and receiver are adjusted before shipment, please apply both emitter and receiver with the same serial No. The serial No. is indicated on the plates of both emitter and receiver. (Indicated under model No.)

- Make sure to carry out the test run before regular operation.
- Do not install this device with a machine whose operation cannot be stopped immediately in the middle of an operation cycle by an emergency stop equipment.

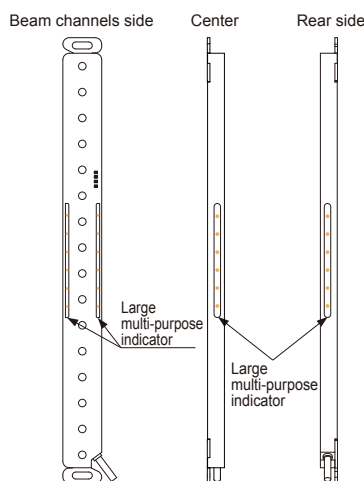



Part description and function

<Indicator part>

**Emitter**

-  Operation indicator [POWER]
-  Test indicator [TEST]
-  Frequency setting indicator [FREQ]
-  Fault indicator [FAULT]

Receiver

-  OSSD indicator [OSSD]
-  Incident light intensity indicator [STB]
-  Frequency setting indicator [FREQ]
-  Fault indicator [FAULT]

Common for emitter and receiver

Description	Function
Large multi-purpose indicator (Orange)	Lights up when input for the large multi-purpose indicator is valid. Turns OFF when input for the large multi-purpose indicator is invalid.
Frequency setting indicator (Orange) [FREQ]	Turns OFF when Frequency 1 is set. Lights up when Frequency 2 is set.
Fault indicator (Yellow) [FAULT]	Turns OFF during normal operation. Lights up or blinks when fault occurs in the device.

Emitter

Description	Function
Operation indicator (Green) [POWER]	Lights up when device operation is as follows. Turns OFF when test input is valid.
Test indicator (Red) [TEST]	Lights up when test input is valid. Turns OFF when test input is invalid.

Receiver

Description	Function
OSSD indicator (Red / green) [OSSD]	When control output (OSSD) is OFF: lights up in red When control output (OSSD) is ON: lights up in green
Unstable light reception indicator (Orange) [STB]	Turns OFF when stable light is received (the percentage of light received is more than 150%). [Control output (OSSD) ON] Lights up when unstable light is received (the percentage of light received is between 100% and 150%). [Control output (OSSD) ON] Turns OFF when light is blocked (the percentage of light received is less than 100%). (Note 1) [Control output (OSSD) OFF]

Notes: 1) Besides, 'when light is blocked' refers to the status that there exists any object blocking light in the sensing area.
2) The description given in [] is marked on the device.

Others

- This device has been developed / produced for industrial use only.
- Do not use during the initial transient time (2 sec.) after the power supply is switched on.
- Avoid dust, dirt and steam.
- Take care that the safety light curtain does not come in direct contact with water, oil, grease, or organic solvents, such as, thinner, etc.
- Take care that the safety light curtain is not directly exposed to fluorescent light from a rapid-starter lamp or a high frequency lighting device, as it may affect the sensing performance.
- The body of this device is made of resin, so please take into account the expansion and contraction of the longitudinal dimension. When machining mounting holes, please check the actual product.

FIBER

SENSORS

LASER

SENSORS

PHOTO-

ELECTRIC

SENSORS

MICRO

PHOTO-

ELECTRIC

SENSORS

AREA

SENSORS

SAFETY LIGHT

CURTAINS /

SAFETY

COMPONENTS

PRESSURE /

FLOW

SENSORS

INDUCTIVE

PROXIMITY

SENSORS

PARTICULAR

USE

SENSORS

SENSOR

OPTIONS

SIMPLE

WIRE-SAVING

UNITS

WIRE-SAVING

SYSTEMS

MEASURE-

MENT

SENSORS

STATIC

CONTROL

DEVICES

LASER

MARKERS

PLC

HUMAN

MACHINE

INTERFACES

ENERGY

MANAGEMENT

SOLUTIONS

FA

COMPONENTS

MACHINE

VISION

SYSTEMS

UV

CURING

SYSTEMS

Selection

Guide

Safety Light

Curtains

Safety

Control Units

Safety

Components

SF4D**SF4B/****SF4B-G****SF4B-C****SF4C****SF2B****SF2C**

Definition of

Sensing Heights

DIMENSIONS (Unit: mm in)

The CAD data can be downloaded from our website.

SF2C-H□

Safety light curtain

Mounting bracket assembly dimensions

Mounting drawing for the safety light curtains using the standard mounting brackets **MS-SFC-1** (accessory).

<Center mounting>

<Dead zoneless mounting>

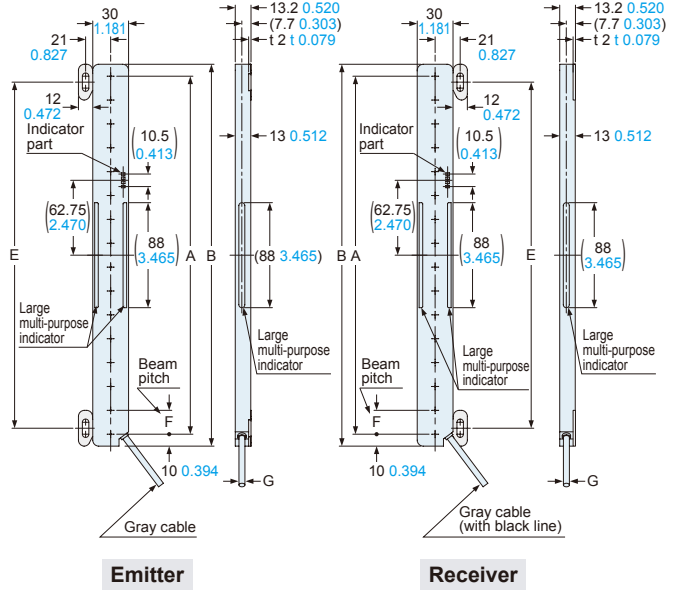
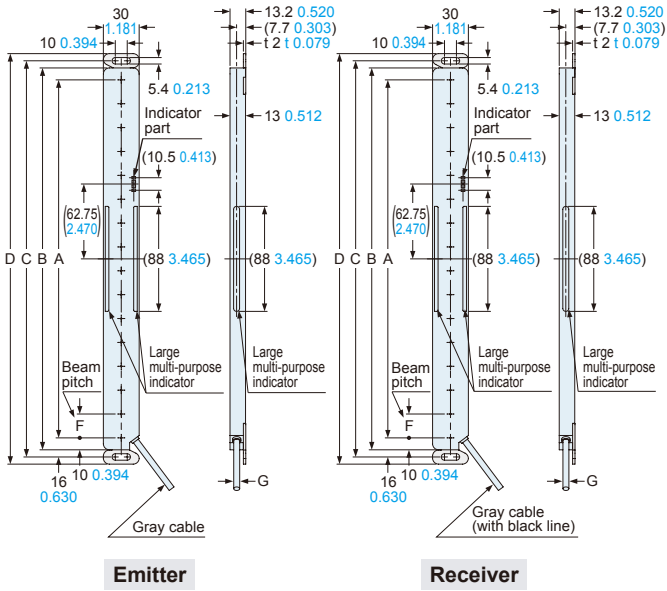

Model No.	A	B	C	D	E
SF2C-H8-□	140 5.512	160 6.299	172 6.772	184 7.244	130 5.118
SF2C-H12-□	220 8.661	240 9.449	252 9.921	264 10.394	210 8.268
SF2C-H16-□	300 11.811	320 12.598	332 13.071	344 13.543	290 11.417
SF2C-H20-□	380 14.961	400 15.748	412 16.220	424 16.693	370 14.567
SF2C-H24-□	460 18.110	480 18.898	492 19.370	504 19.842	450 17.717
SF2C-H28-□	540 21.260	560 22.047	572 22.520	584 22.992	530 20.866
SF2C-H32-□	620 24.409	640 25.197	652 25.669	664 26.142	610 24.016

Model No.	F	G
SF2C-H□	20 0.787	ø3.7 ø0.146

Note: The body of the safety light curtain is made of resin, so please take into account the expansion and contraction of the longitudinal dimension. When machining mounting holes, please check the actual product.

- Selection Guide
- Safety Light Curtains
- Safety Control Units
- Safety Components

- SF4D
- SF4B/SF4B-G
- SF4B-C
- SF4C
- BSF4-AH80
- SF2B
- SF2C**
- Definition of Sensing Heights

DIMENSIONS (Unit: mm in)

The CAD data can be downloaded from our website.

SF2C-H□

Safety light curtain

Assembly dimensions

Mounting drawing for the safety light curtains using the versatile brackets **MS-SFC-3** (optional) and intermediate supporting bracket for versatile brackets **MS-SFC-4** (optional).

<Rear mounting>

<Dead zoneless mounting>

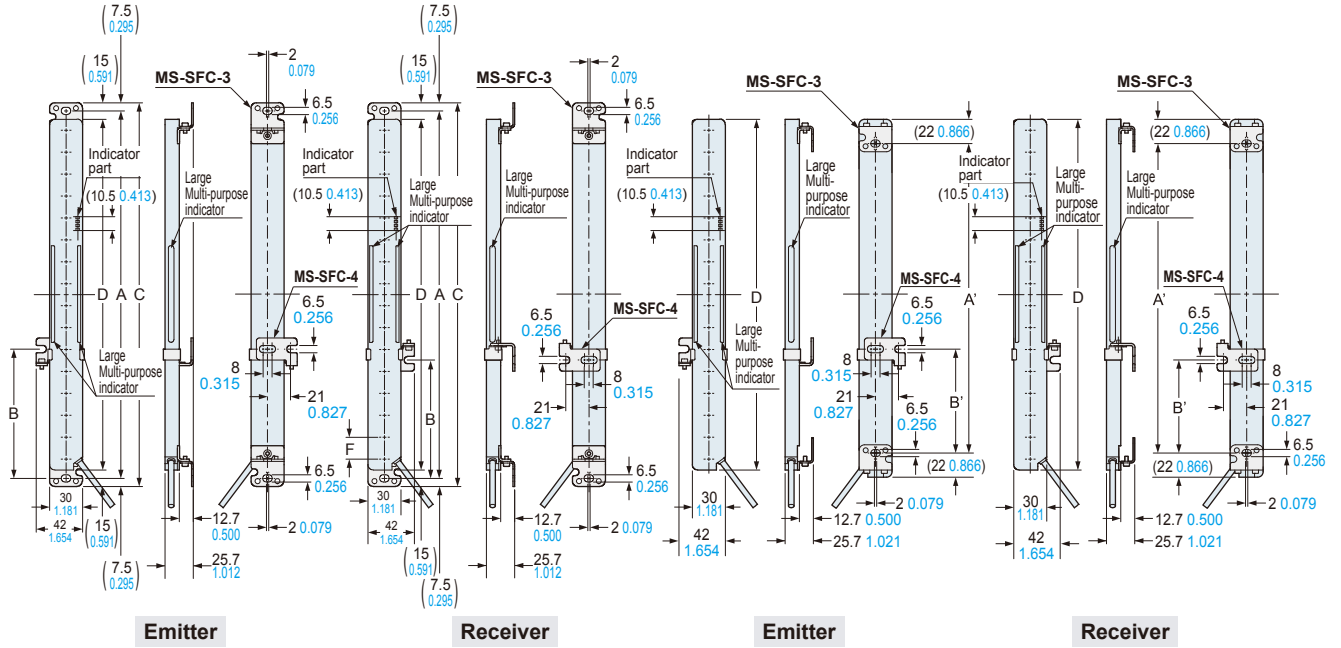

Model No.	Inter mediate supporting bracket	A	A'	B	B'	C	D
SF2C-H8-□	—	175	116	—	—	190	160
		6.890	4.567	—	—	7.480	6.299
SF2C-H12-□	—	255	196	—	—	270	240
		10.039	7.717	—	—	10.630	9.449
SF2C-H16-□	—	335	276	—	—	350	320
		13.189	10.866	—	—	13.780	12.598
SF2C-H20-□	—	415	356	—	—	430	400
		16.339	14.016	—	—	16.929	15.748
SF2C-H24-□	—	495	436	—	—	510	480
		19.488	17.165	—	—	20.079	18.898
SF2C-H28-□	○	575	516	238 to 338	209 to 309	590	560
		22.638	20.315	9.370 to 13.307	8.228 to 12.165	23.228	22.047
SF2C-H32-□	○	655	596	278 to 378	249 to 349	670	640
		25.787	23.465	10.945 to 14.882	9.803 to 13.740	26.378	25.197

- Notes: 1) Be sure to mount **MS-SFC-4** when using **SF2C-H28-□**, **SF2C-H32-□**.
 2) The body of the safety light curtain is made of resin, so please take into account the expansion and contraction of the longitudinal dimension. When machining mounting holes, please check the actual product.

FIBER SENSORS

LASER SENSORS

PHOTO-ELECTRIC SENSORS

MICRO PHOTO-ELECTRIC SENSORS

AREA SENSORS

SAFETY LIGHT CURTAINS / SAFETY COMPONENTS

PRESSURE / FLOW SENSORS

INDUCTIVE PROXIMITY SENSORS

PARTICULAR USE SENSORS

SENSOR OPTIONS

WIRE-SAVING UNITS

WIRE-SAVING SYSTEMS

MEASUREMENT SENSORS

STATIC CONTROL DEVICES

LASER MARKERS

PLC

HUMAN MACHINE INTERFACES

ENERGY MANAGEMENT SOLUTIONS

FA COMPONENTS

MACHINE VISION SYSTEMS

UV CURING SYSTEMS

Selection Guide

Safety Light Curtains

Safety Control Units

Safety Components

SF4D

SF4B/ SF4B-G

SF4B-C

SF4C

BSF4-AH80

SF2B

SF2C

Definition of Sensing Heights

DIMENSIONS (Unit: mm in)

The CAD data can be downloaded from our website.

MS-SFC-1 Standard mounting bracket (Accessory)

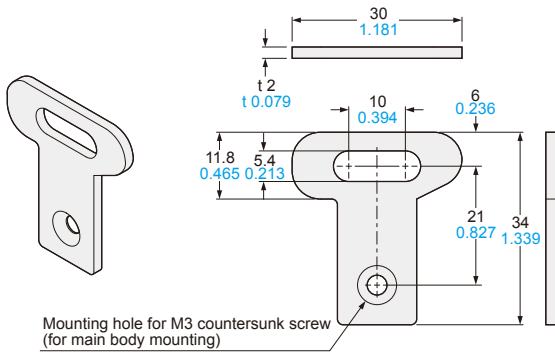

Material: Stainless steel (SUS304)
 Net weight: 32 g approx. (4 pcs.)
 Gross weight: 35 g approx.

Four bracket set
 [Four M3 (length 4 mm 0.157 in) countersunk screws are attached.]

MS-SFC-2 NA2-N compatible mounting bracket (Optional)

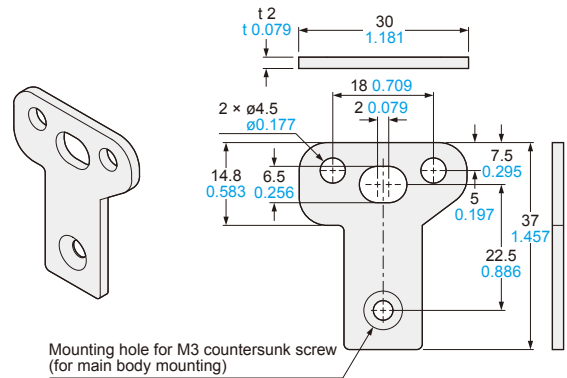

Material: Stainless steel (SUS304)
 Net weight: 36 g approx. (4 pcs.)
 Gross weight: 40 g approx.

Four bracket set
 [Four M3 (length 4 mm 0.157 in) countersunk screws are attached.]

MS-SFC-3 Versatile bracket (Optional)

<Rear mounting>

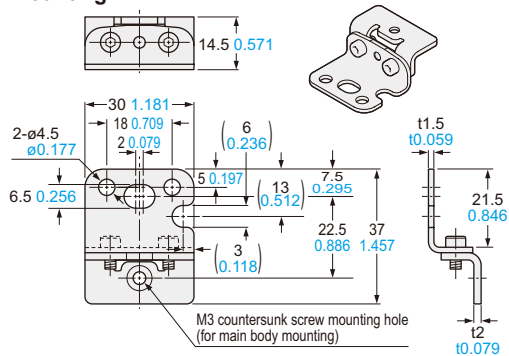

Material: Stainless steel (SUS304)
 Net weight: 75 g approx. (4 pcs.)
 Gross weight: 90 g approx.

Four bracket set
 [Four M3 (length 4 mm 0.157 in) countersunk screws are attached.]

<Dead zoneless mounting>

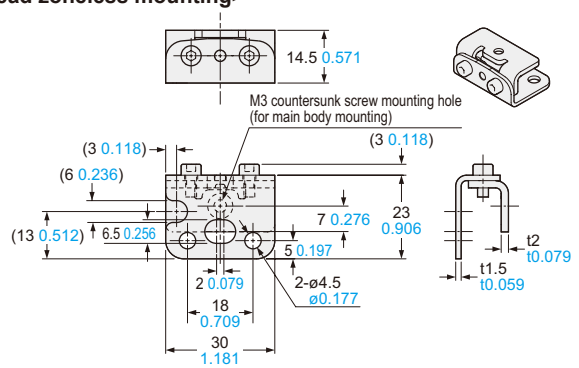

MS-SFC-4 Intermediate supporting bracket for versatile bracket (Optional)

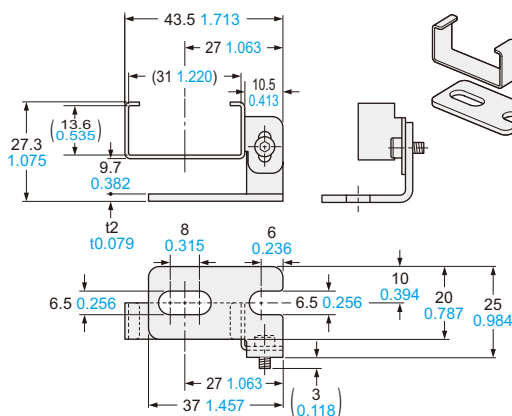

Material: Stainless steel (SUS304)
 Net weight: 40 g approx. (2 pcs.)
 Gross weight: 60 g approx.

Two bracket set

FIBER SENSORS
LASER SENSORS
PHOTO-ELECTRIC SENSORS
MICRO PHOTO-ELECTRIC SENSORS
AREA SENSORS
SAFETY LIGHT CURTAINS / SAFETY COMPONENTS
PRESSURE / FLOW SENSORS
INDUCTIVE PROXIMITY SENSORS
PARTICULAR USE SENSORS
SENSOR OPTIONS
SIMPLE WIRE-SAVING UNITS
WIRE-SAVING SYSTEMS
MEASUREMENT SENSORS
STATIC CONTROL DEVICES
LASER MARKERS
PLC
HUMAN MACHINE INTERFACES
ENERGY MANAGEMENT SOLUTIONS
FA COMPONENTS
MACHINE VISION SYSTEMS
UV CURING SYSTEMS
Selection Guide
Safety Light Curtains
Safety Control Units
Safety Components
SF4D
SF4B / SF4B-G
SF4B-C
SF4C
BSF4-AH80
SF2B
SF2C
Definition of Sensing Heights

DIMENSIONS (Unit: mm in)

The CAD data can be downloaded from our website.

MS-SFCH-□

Metal protection case (Optional)

Assembly dimensions

Mounting drawing for the safety light curtains using the metal protection case (**MS-SFCH-□**).

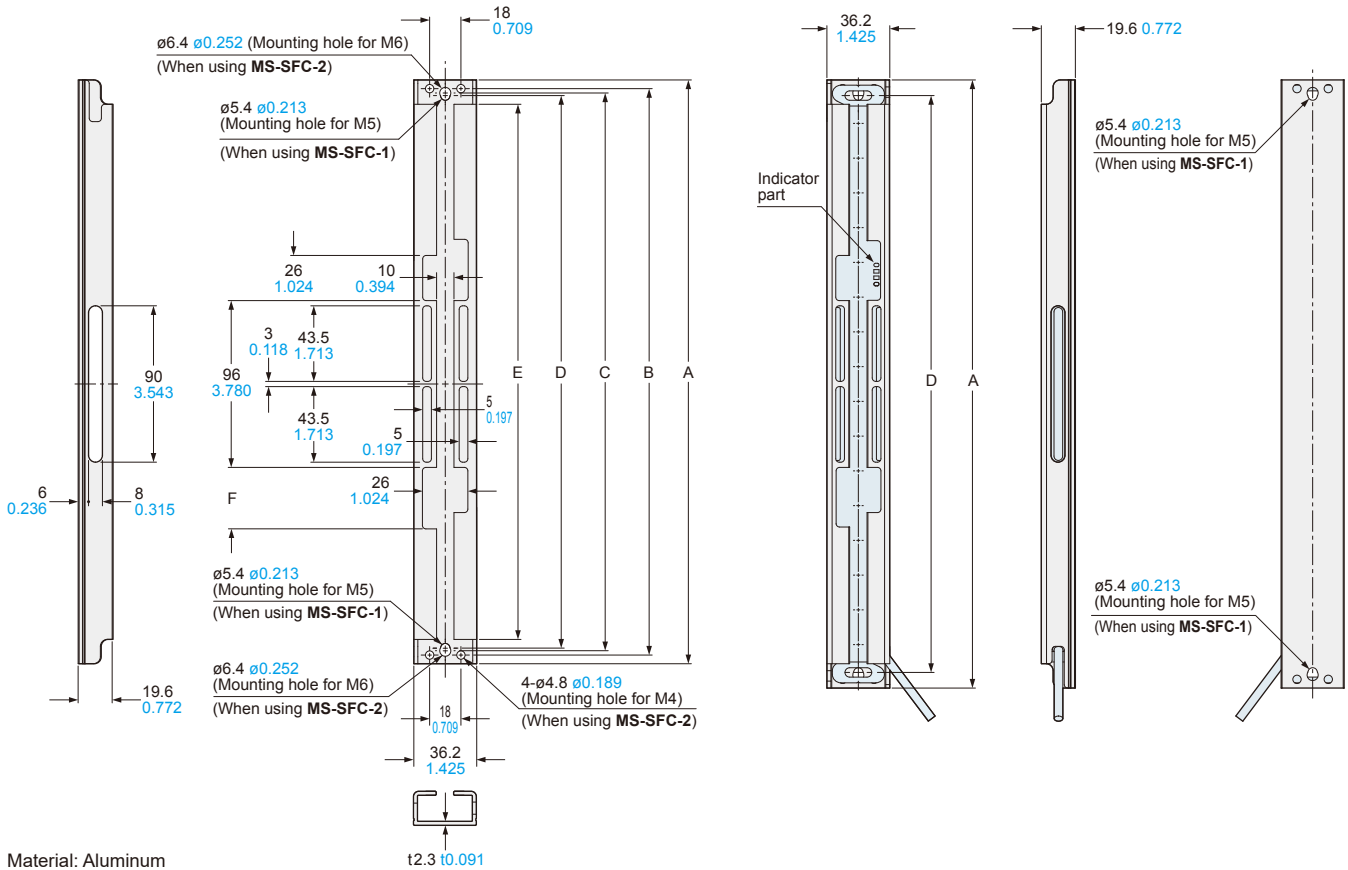

Model No.	A	B	C	D	E	F	Net weight (2 pcs.)
MS-SFCH-8	190 7.480	180 7.087	175 6.890	172 6.772	162 6.378	26 1.024	160 g approx.
MS-SFCH-12	270 10.630	260 10.236	255 10.039	252 9.921	242 9.528	35 1.378	240 g approx.
MS-SFCH-16	350 13.780	340 13.386	335 13.189	332 13.071	322 12.677	35 1.378	340 g approx.
MS-SFCH-20	430 16.929	420 16.535	415 16.339	412 16.220	402 15.827	35 1.378	420 g approx.
MS-SFCH-24	510 20.079	500 19.685	495 19.488	492 19.370	482 18.976	35 1.378	520 g approx.
MS-SFCH-28	590 23.228	580 22.835	575 22.638	572 22.520	562 22.126	35 1.378	600 g approx.
MS-SFCH-32	670 26.378	660 25.984	655 25.787	652 25.669	642 25.276	35 1.378	700 g approx.

SF-C13

Control unit (Optional)

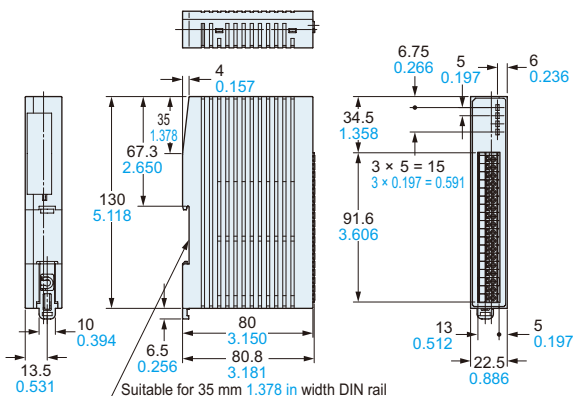

FIBER SENSORS

LASER SENSORS

PHOTO-ELECTRIC SENSORS

MICRO PHOTO-ELECTRIC SENSORS

AREA SENSORS

SAFETY LIGHT CURTAINS / SAFETY COMPONENTS

PRESSURE / FLOW SENSORS

INDUCTIVE PROXIMITY SENSORS

PARTICULAR USE SENSORS

SENSOR OPTIONS

SIMPLE WIRE-SAVING UNITS

WIRE-SAVING SYSTEMS

MEASUREMENT SENSORS

STATIC CONTROL DEVICES

LASER MARKERS

PLC

HUMAN MACHINE INTERFACES

ENERGY MANAGEMENT SOLUTIONS

FA COMPONENTS

MACHINE VISION SYSTEMS

UV CURING SYSTEMS

Selection Guide

Safety Light Curtains

Safety Control Units

Safety Components

SF4D

SF4B/ SF4B-G

SF4B-C

SF4C

SF4-AH80

SF2B

SF2C

Definition of Sensing Heights