

RV[®]



Precision Reduction Gear RV[™]
Compact Actuator

AF

AF Series

ALL in ONE

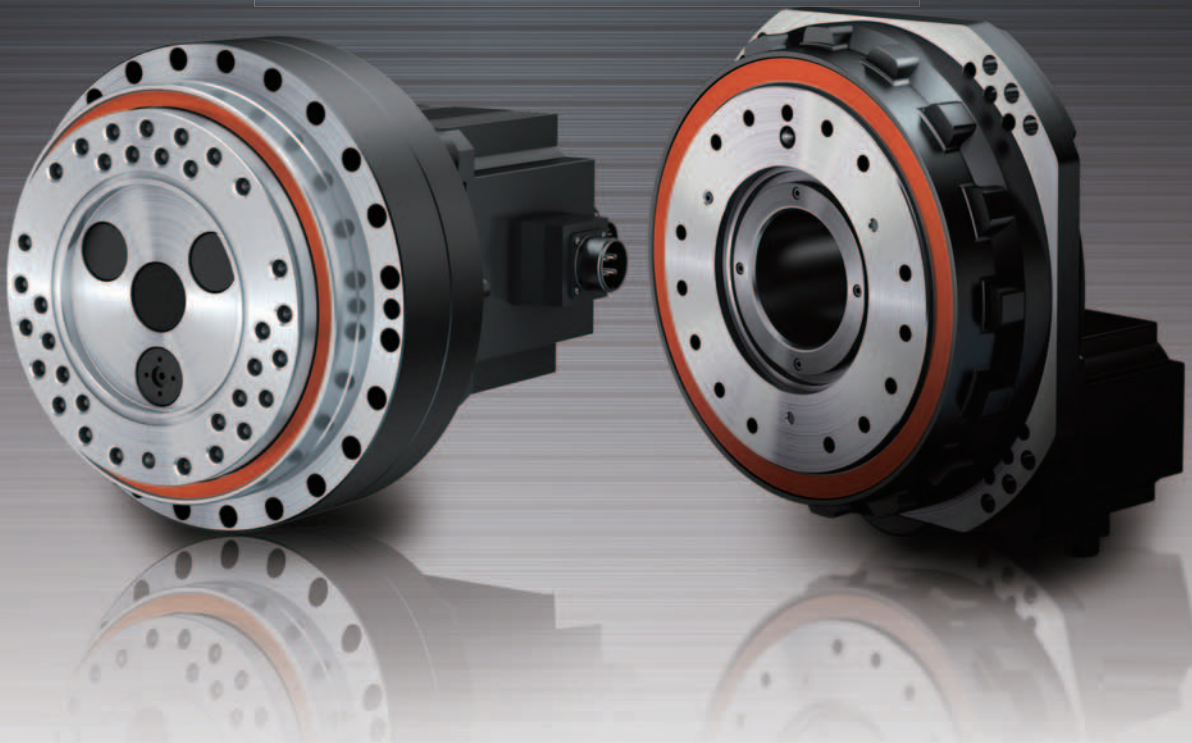

Nabtesco



Contributing to society with our 'Moving it. Stopping it.' technologies

Nabtesco manufactures products which are used in everyday life. Our high-accuracy components are essential for moving objects; they may be rarely visible, but are the foundation of everyday objects that you see moving and wonder how. Nabtesco's technologies are found throughout objects that move and stop people's lives.

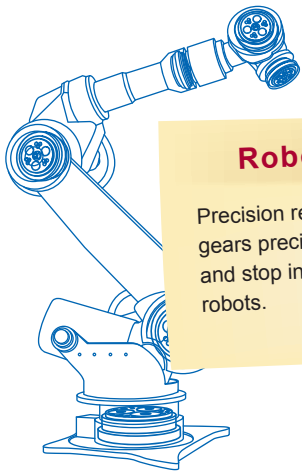

Robots

Precision reduction gears precisely move and stop industrial robots.

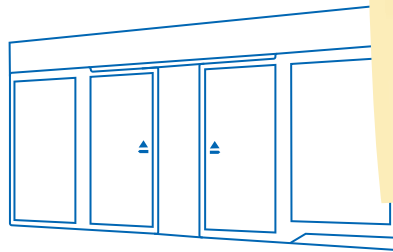

Doors

Nabtesco technology opens and closes automatic doors in buildings and platform doors at train stations.

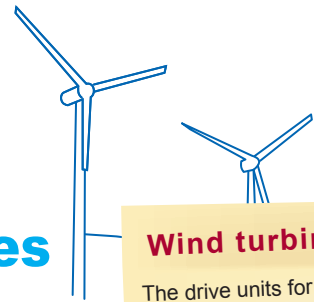

Wind turbines

The drive units for wind turbine generators control the orientation of the wind turbine and the angle of the blades.

Nabtesco technologies are at work in many areas of our daily lives.

Construction machinery

Running motors and control valves start and stop hydraulic excavators.

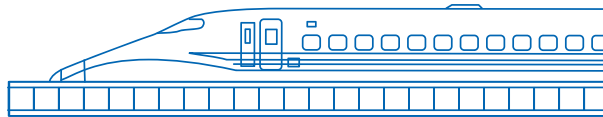
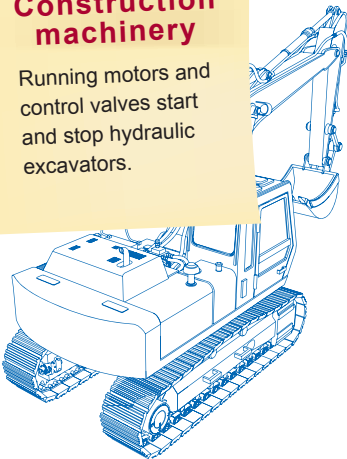

Bullet trains

Brakes and doors ensure safety and comfort for the world-famous Shinkansen bullet trains.

Tankers

The engine remote control systems for vessels move and stop large vessels.

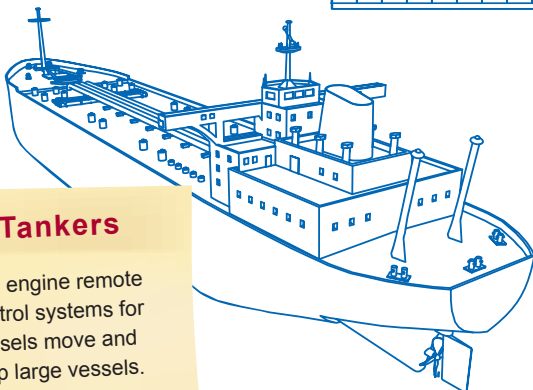

Airplanes

The flight control systems are crucial for the flight safety of aircraft.

CONTENTS

Who is Nabtesco?

The key words for Nabtesco are 'motion control'. We use our strengths in the fields of component and systems technologies to develop highly creative products. Through the Nabtesco Group as a whole, we can also utilize our advantage of expertise to maximum effect in order to further enhance these strengths.

In the air, on land and at sea, we have established a large share in various fields of both international and domestic markets. Nabtesco will continue to evolve by utilizing its strengths in many fields and by exploring the possibilities of the future.



Nabtesco

April 2002 Initiation of hydraulic equipment business alliance
October 2003 Business merger

The business alliance between Teijin Seiki and NABCO on hydraulic equipment projects was the beginning of a mutual confirmation by the companies of the other's product configuration, core technologies, corporate strategies and corporate culture. This led to a common recognition that a business merger would be an extremely effective means of increasing corporate value and achieving long-term development. Based on this mutual judgment, in 2003 an equity transfer was conducted to establish Nabtesco as a pure holding company, with both firms as wholly owned subsidiaries. After a year of preparation, both companies were absorbed and amalgamated by means of a short form merger, and Nabtesco was transitioned to an operating holding company.

What is the AF series ?	02 – 03
Main Applications	04 – 05
Benefits	06 – 07
Overall Wiring	07
Structure	08 – 09
Principle of speed reduction	10
Specifications, external dimensions	
Specifications	12 – 18
External dimensions	19 – 30
Technical Information	
Considering the use	32
Glossary	33
Product Selection	
Product selection flowchart	34
Model code selection examples	35 – 41
Technical Data	
Calculation of tilt angle and torsion angle	42
Design Points	
Design of actuator installation components	43 – 44
Lubricant	45
Appendix	
Inertia moment calculation formula	46
Warranty	Back inside cover

Actuator for Factory Automation

Evolving into  ALL in ONE

Do you want to automate –but don't have the time to spend selecting, designing and producing components? The AF series was created to provide a solution in such circumstances-to achieve automation as simple and quickly as possible. This has been achieved by integrating our precision reduction gear RV with servomotors from Panasonic Corporation into a simple, compact design. The resulting high quality unified drive section ensures safety, comfort, and a sense of security.





RV precision gears utilize a planocentric deceleration mechanism for high-precision control. RV precision gears are compact and lightweight, and because RV precision gears include many simultaneously meshing surfaces, they feature high rigidity and strong resistance to overload. The design of the RV precision gear minimizes backlash, rotational vibration, and inertia; which leads to excellent acceleration performance, smooth movement, and high positioning accuracy. RV precision gears have a proven track record in many fields of automation, including: industrial robots, machine tools, assembly equipment, and transportation equipment.

- ▶ High rigidity and High impact resistance
- ▶ High output torque and High durability
- ▶ Low vibration
- ▶ Wide reduction ratio range
- ▶ Flat and Compact
- ▶ High precision positioning (precise rotation)

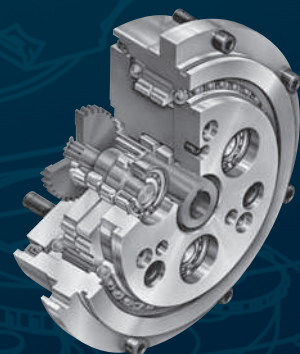

Main Applications

The following are example applications of automation using the AF series. However, these precision gears can be incorporated into a variety of other applications.

Palletizing robot and Index table

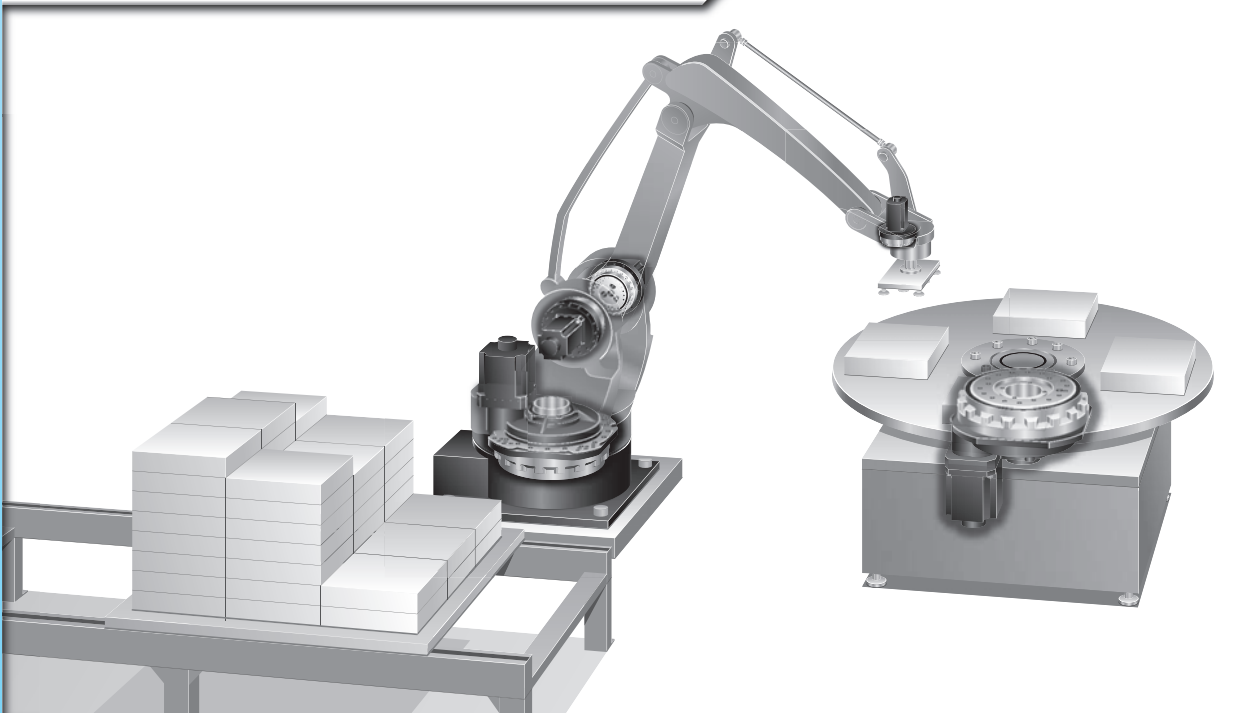

Various types of positioners

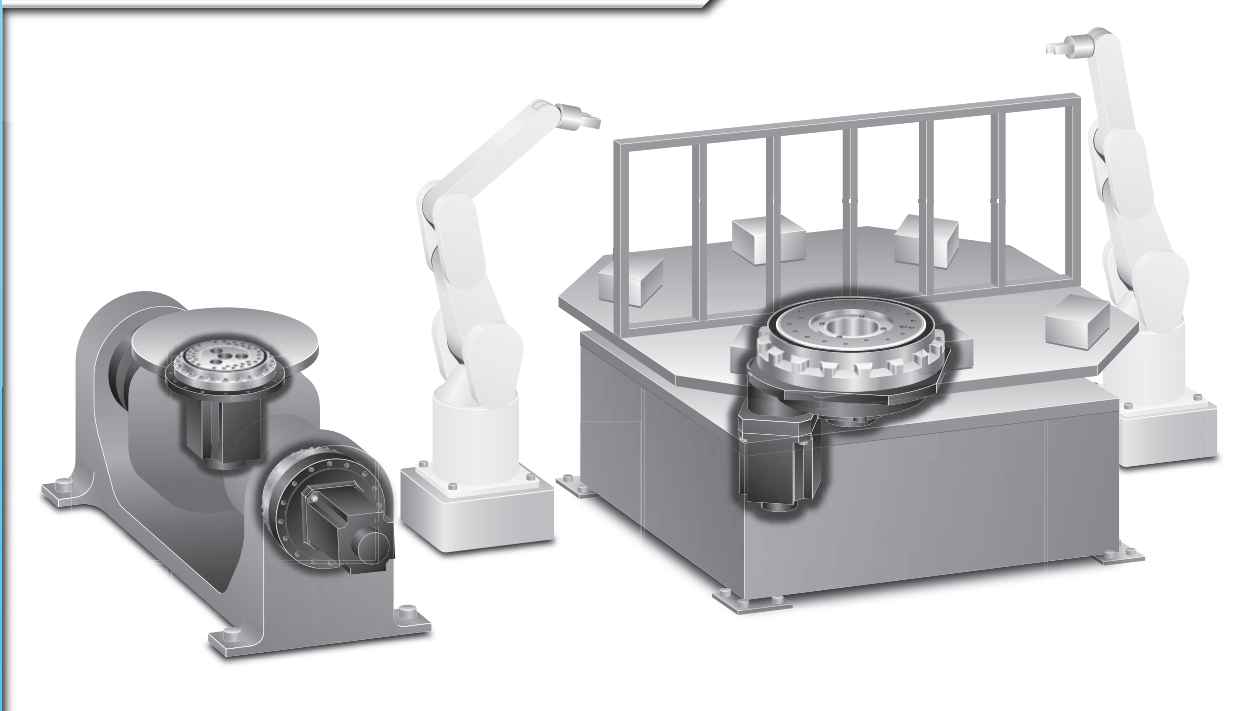

Gantry loader and ATC magazine

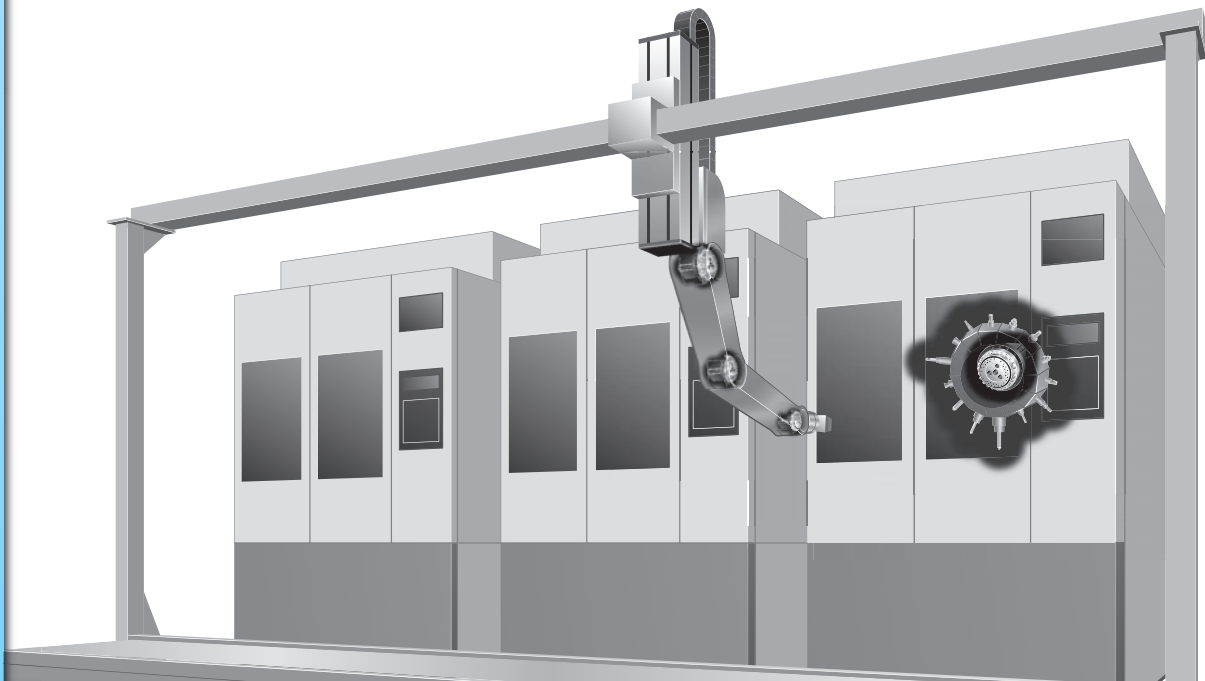

SCARA robot and Cylindrical coordinate robot

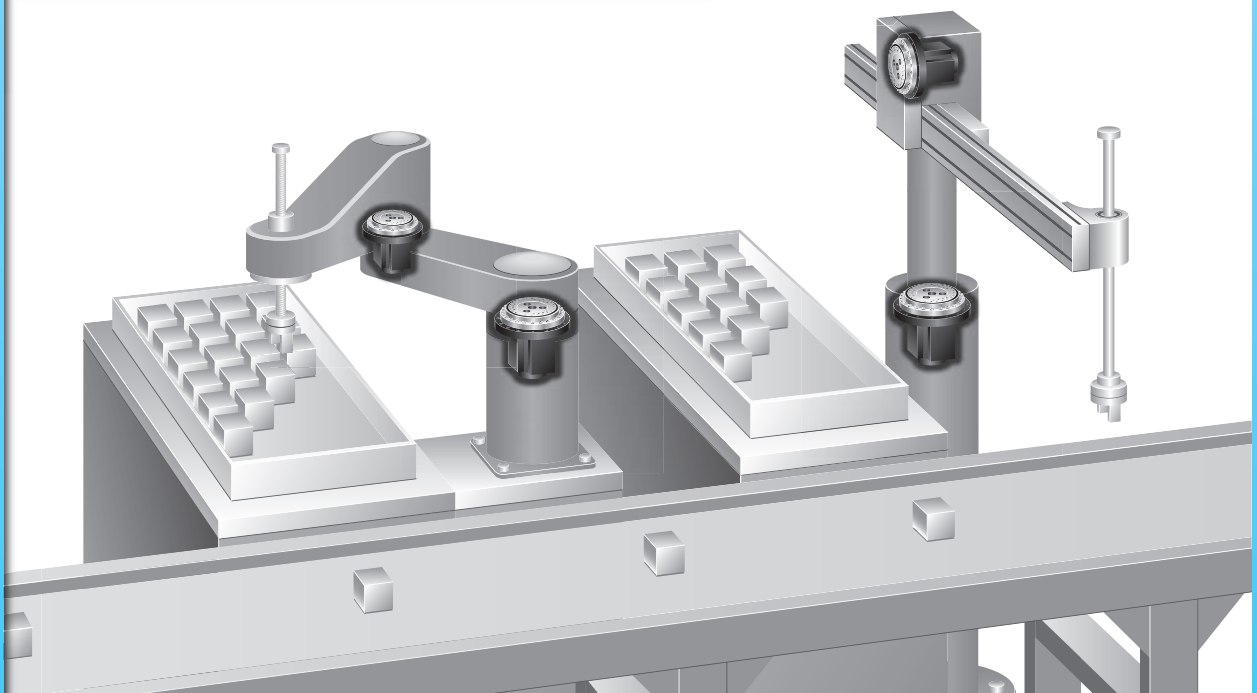

Benefits

The AF series can solve your problems.

Merit 1 Compact design

Before

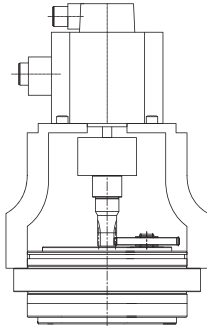

The total length is extended due to the input gear and coupling.



With the AF series...

After

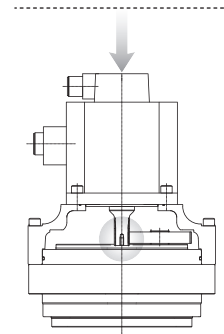

The machining of gears onto the motor shaft results in a very compact design; up to 23% shorter than conventional models.

Merit 2 Greater reliability

Before

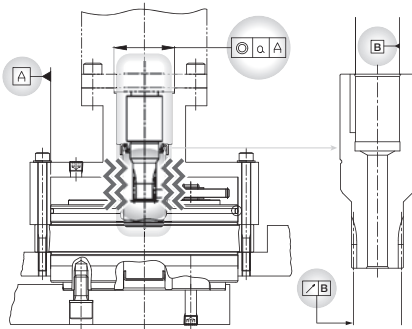

Machining is very difficult, resulting in axial runout, poor concentricity accuracy, and producing abnormal noise.



With the AF series...

After

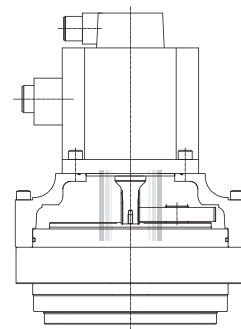

Shipped after machining and assembly, no need to worry about abnormal noise.

Merit 3 Greater quality

Before

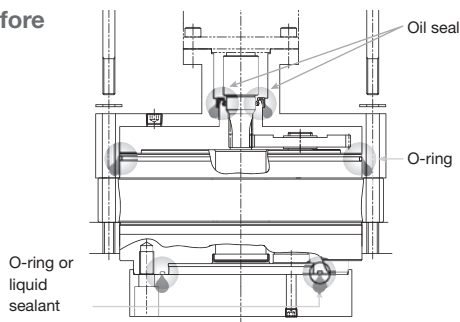

Greasing can be troublesome, If seals are forgotten, grease can leak



With the AF series...

After

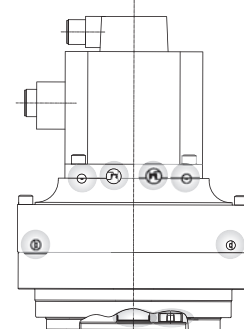

Already contains grease; no need to worry about leaking.

Merit 4 Fewer parts, easier installation

Before

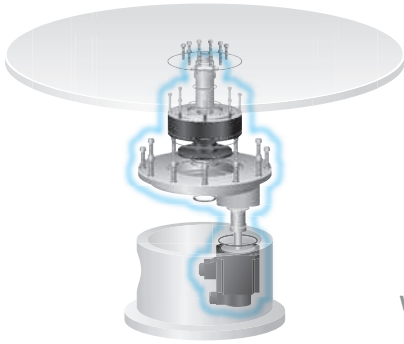

More components increase design and assembly times...

After

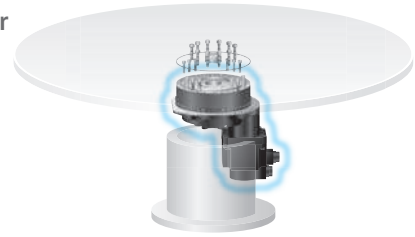

Integrated unit of motor and reduction gear has realized easier assembly; reduces work times.

With the AF series...

Overall Wiring

Nabtesco AF series

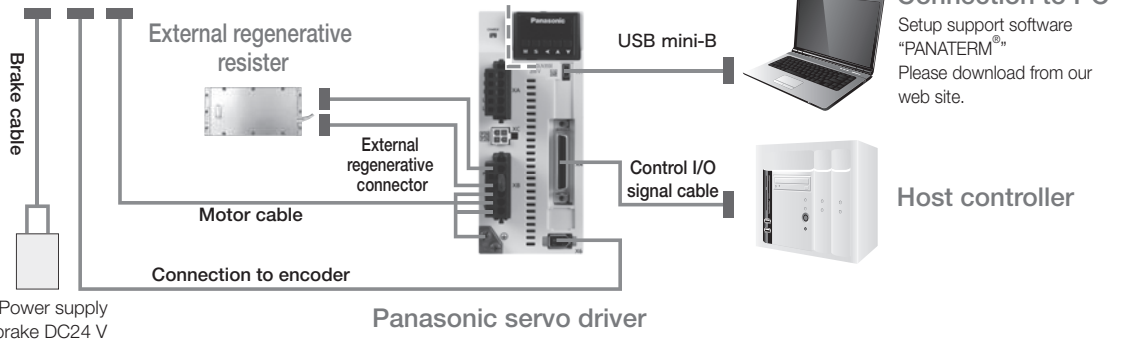
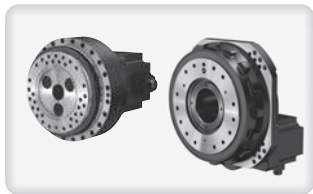

The setup support software "PANATERM[®]" is a software product that is installed into your personal computer and allows you to set necessary parameters, monitor the control status, support the setup, and analyze the machine on the personal computer screen via serial communication between the MINAS-A6/A5 families and USB.

- Four languages, which are Japanese, English, Chinese, and Korean are supported.

If anything is unclear or you need more detailed information, check the following URL.

Panasonic download site <http://industrial.panasonic.com/ww/products/motors-compressors/motors-for-fa-and-industrial-application>

Structure

•Solid type without brake (AF017N 0.4 kW)

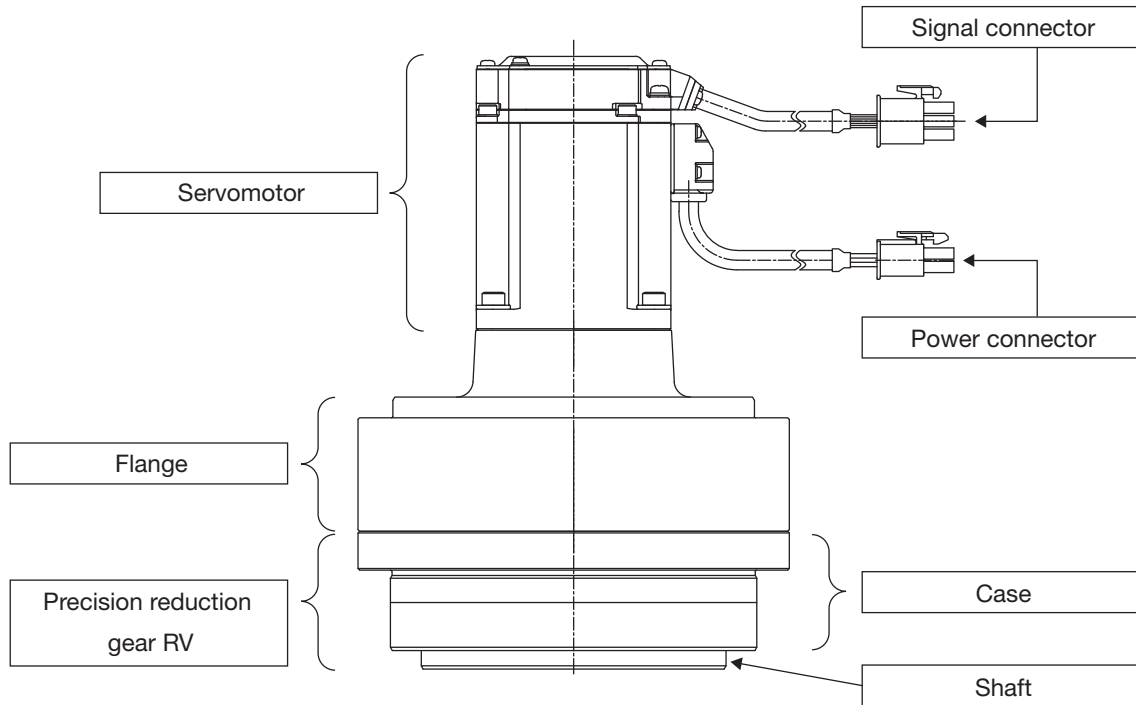

•Solid type with brake (AF017N 0.4 kW)

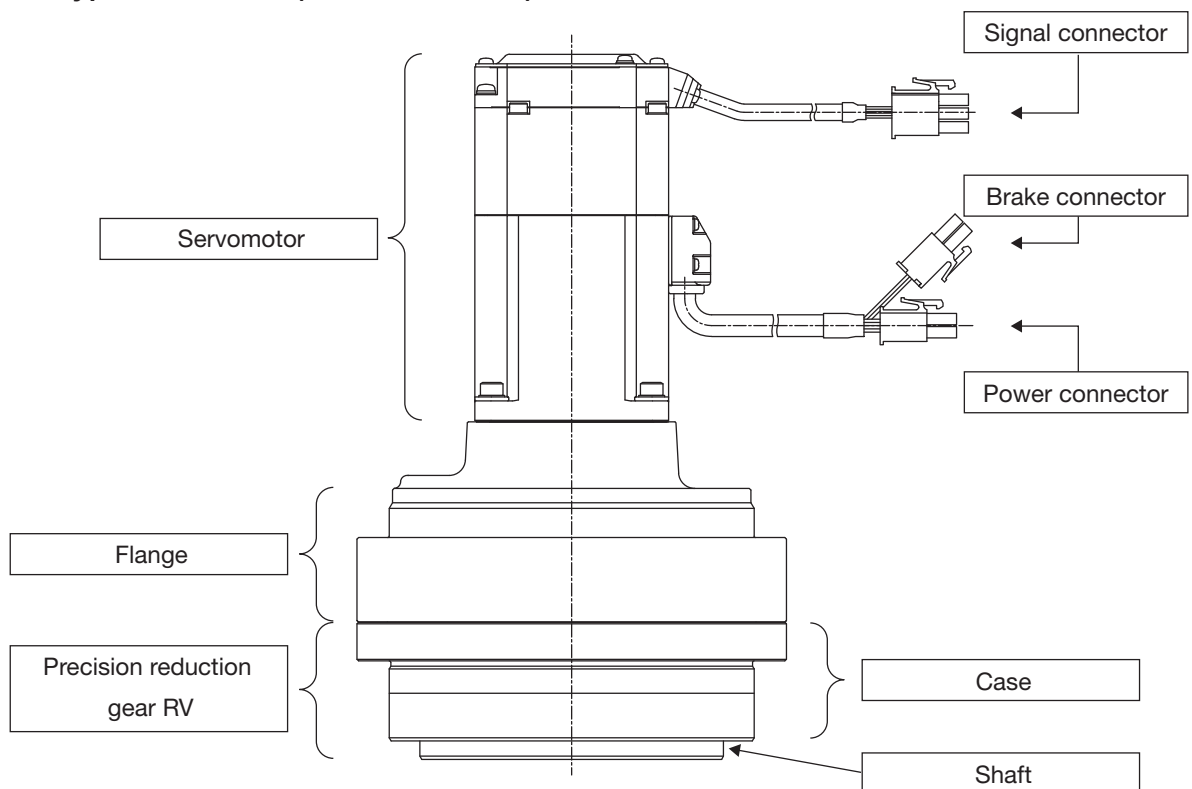

•Solid type (AF017N 1.0 kW, AF042N 1.0 kW & 1.5 kW, AF080N, AF125N, AF380N, AF500N)

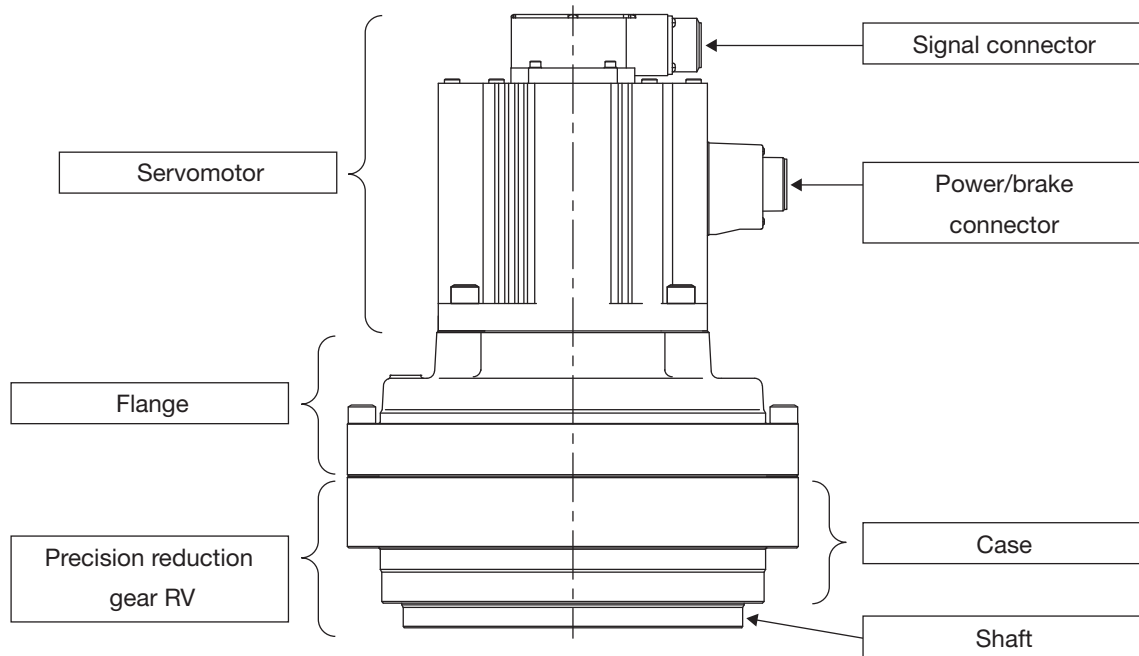

•Hollow shaft type (AF050C, AF120C, AF200C, AF320C)

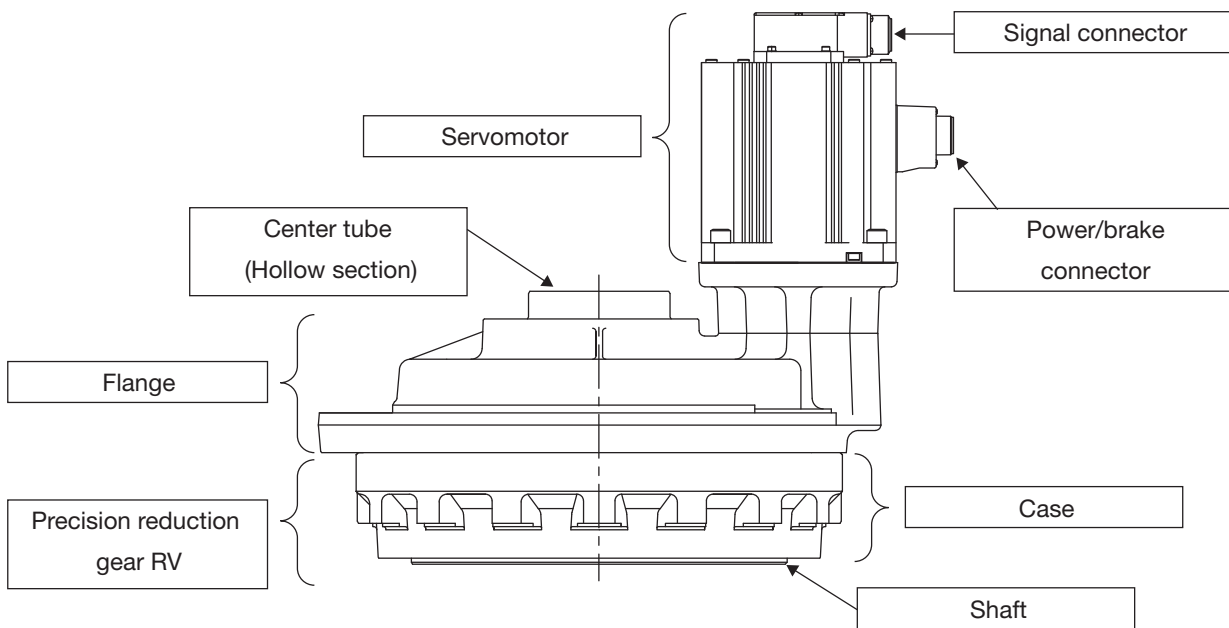

Principle of speed reduction

The RV is a 2-stage precision reduction gear.

1st stage ... Spur gear reduction

- An input gear engages with and rotates spur gears that are coupled to crankshafts. Several overall gear ratios can be provided by selecting various first stage ratios.

2nd stage ... Epicyclic gear reduction

- Crankshafts driven by the spur gears cause an eccentric motion of two epicyclic gears called RV gears that are offset 180 degrees from one another to provide a balanced load.
- The eccentric motion of the RV gears causes engagement of the cycloidal shaped gear teeth with cylindrically shaped pins located around the inside edge of the case.
- In the course of one revolution of the crankshafts the teeth of the RV gear move the distance of one pin in the opposite direction of the rotating cranks. The motion of the RV gear is such that the teeth remain in close contact with the pins and multiple teeth share the load simultaneously.
- The output can be either the shaft or the case. If the case is fixed, the shaft is the output. If the shaft is fixed, the case is the output.

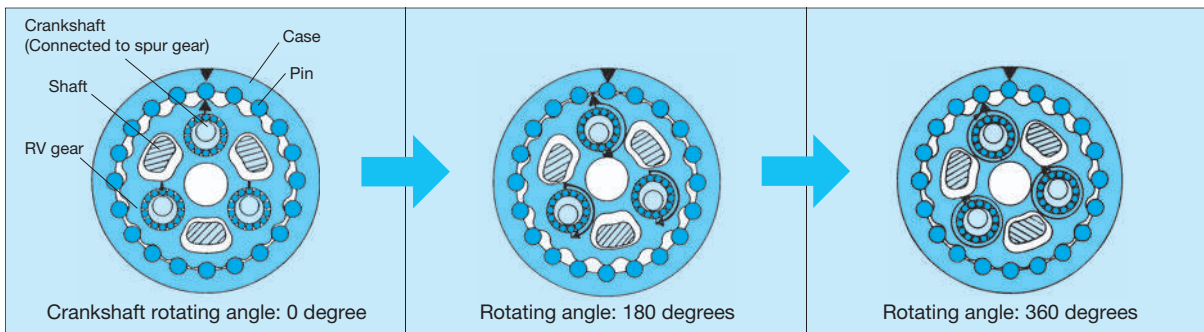

Mechanism block diagram

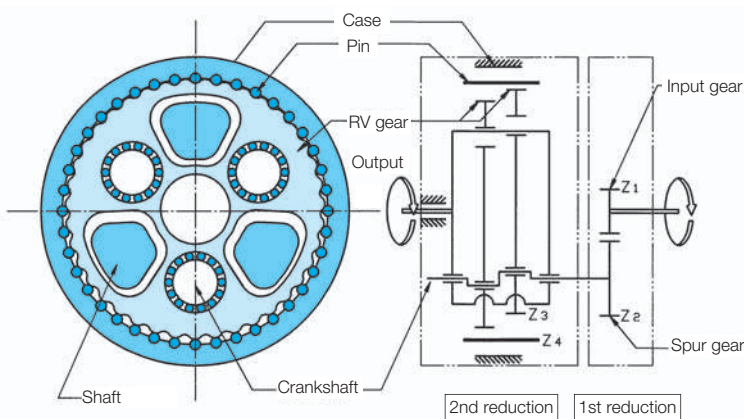

Structure

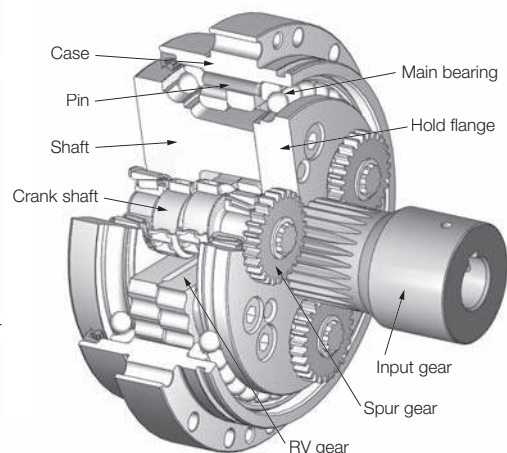

Speed Ratio

The speed ratio is calculated using the formula to the right.

$$R = 1 + \frac{Z_2}{Z_1} \cdot Z_4$$

$$i = \frac{1}{R}$$

R : Speed ratio

Z1 : Number of teeth on input gear

Z2 : Number of teeth on spur gear

Z3 : Number of teeth on RV gear

Z4 : Number of pins

i : Reduction ratio



Specifications, external dimensions

Specifications

Description of model code

AF
120
C
120
 –
 P
7
1
 –
 0
B
 –
 D
0

①
②
③
④
⑤
⑥
⑦
⑧
⑨
⑩

Item	Meaning	Code	Meaning	Additional information
①	Reduction gear frame number	***	Frame number	
②	Reduction gear shape	N	N: Solid type	
		C	C: Hollow shaft type	
③	Reduction speed ratio	***	Reduction speed ratio	Values after the decimal point are omitted.
④	Motor manufacturer	P	Panasonic Corporation	
⑤	Motor capacity	0	0.4kW	
		1	1.0kW	
		2	3.0kW	
		3	4.0kW	
		4	4.5kW	
		5	5.0kW	
		6	1.5kW	
		7	2.0kW	
⑥	Motor series	0	MINAS A5	Servomotor made by Panasonic Corporation
		1	MINAS A6	
⑦	Motor brake	0	Without brake	
		B	With brake	
⑧	Encoder specifications	A	17-bit absolute	Indicates the specifications of the encoder incorporated in the servomotor. MINAS A5 is 17-bit absolute while MINAS A6 is 23-bit absolute.
		B	23-bit absolute	
⑨	Fixed code	S	S: For solid type	
		D	D: For hollow shaft type	
⑩	Option code	0	Standard component	Currently, only the option code for standard components is available.

List of all AF series models

Motor series: MINAS A6

Solid type	Hollow shaft type
AF017N081-P01-0B-S0	AF050C120-P11-0B-D0
AF017N081-P01-BB-S0	AF120C120-P71-0B-D0
AF017N126-P11-BB-S0	
AF042N126-P11-BB-S0	
AF042N126-P61-BB-S0	
AF080N129-P71-BB-S0	

Motor series: MINAS A5

Solid type	Hollow shaft type
AF042N093-P10-BA-S0	AF200C155-P20-BA-D0
AF125N102-P20-BA-S0	AF320C157-P50-BA-D0
AF380N217-P30-BA-S0	
AF500N252-P30-BA-S0	

Rotation section selection

For this product, the fixed and rotation sections can be selected. Select appropriate fixed and rotation sections according to the requirements for the customer's device.

•Rotation section of case-fixed shaft rotation model

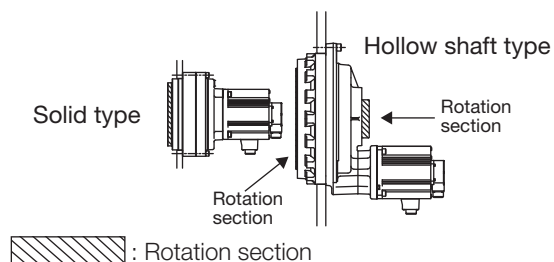

•Rotation section of shaft-fixed case rotation model

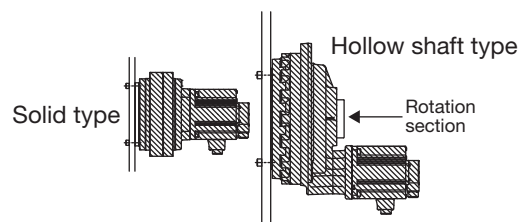

Note) When using this product with case rotation, be careful about tangling of cables as the motor and cables connected to the motor also rotate.

Rotation direction

The relationship between the motor rotation direction and output stage rotation direction is shown below. As the motor rotation direction and output stage rotation direction may be reversed, check the following table.

		Motor rotation direction	
		CW	CCW
Shaft rotation direction when the case is fixed	Solid type	CW	CCW
	Hollow shaft type	CCW	CW
Case rotation direction when the shaft is fixed	Solid type	CCW	CW
	Hollow shaft type	CW	CCW

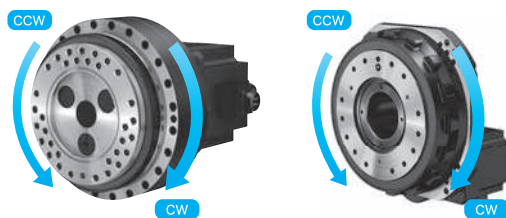

Note: CW indicates clockwise and CCW indicates counterclockwise when viewed from the output side.

International standards

The servomotor incorporated into this product complies with the UL, CSA standards and EU directive.

Specifications

Rating table

Motor series: MINAS A6

		Solid type					Hollow shaft type	
		AF017N *8		AF042N		AF080N	AF050C	AF120C
Rated torque *1	Nm	82 *9	415	481	722	986	460	917
Rated output speed *1	min ⁻¹	37.0	15.9	15.9	15.9	15.5	16.6	16.7
Momentary maximum torque *2	Nm	289	415	1,029	1,029	1,960	1,225	2,746
Momentary maximum output speed	min ⁻¹	80.2	31.7	31.7	31.7	31.0	33.2	33.3
Motor torque limit *2	%	350	86	214	142	198	266	299
Brake holding torque (Min.) *3	Nm	130(-)	1,726	1,726	1,726	1,767	-	-
Single-direction repeatability (Max.)	arc.sec.	70	70	60	60	50	60	50
Allowable load inertia moment	kgm ²	11	117	117	164	221	84	158
Allowable moment *4	Nm	784	784	1,660	1,660	2,150	1,764	3,920
Allowable radial load *5	N	6,975	6,975	12,662	12,662	14,163	9,428	18,702
Mass	kg	7.2(6.8)	15	16	17	26	32	43
Reduction gear	RV precision reduction gear frame number	RV-17N		RV-42N		RV-80N	RV-50C	RV-120C
	Reduction speed ratio	81	126	126	126	129	120.47 (2289/19)	120
	Rated torque	166	166	412	412	784	490	1,176
	Rated speed	15	15	15	15	15	15	15
	Rated service life	6,000	6,000	6,000	6,000	6,000	6,000	6,000
	Backlash	≤1	≤1	≤1	≤1	≤1	≤1	≤1
	Lost motion	≤1	≤1	≤1	≤1	≤1	≤1	≤1
	Spring constant	36	36	113	113	212	255	588
	Moment rigidity	515	515	840	840	1,190	1,960	4,263
Manufacturer	Panasonic Corporation							
Representative model	MHMF042	MDMF102	MDMF102	MDMF152	MDMF202	MDMF102	MDMF202	
Rated capacity	0.4	1.0	1.0	1.5	2.0	1.0	2.0	
Rated current	2.1	5.2	5.2	8.0	9.9	5.2	9.9	
Momentary maximum current	10	22	22	34	42	22	42	
Motor *6	Excitation voltage DC	24±2.4(-)	24±2.4	24±2.4	24±2.4	24±2.4	-	-
	Excitation current DC	0.36(-)	0.79±0.079	0.79±0.079	0.79±0.079	0.79±0.079	-	-
	Suction time (Max.)	50(-)	100	100	100	100	-	-
	Release time (Max.) *7	20(-)	50	50	50	50	-	-
Encoder	Single rotation: 23-bit absolute, Multi-rotation: 16-bit (battery backup)							
Compatible servo amplifier (Panasonic Corporation) *6								
A6SE: Position control type	MBDLN25SExxx	MDDL45SExxx	MDDL45SExxx	MDDL55SExxx	MEDLN83SExxx	MDDL45SExxx	MEDLN83SExxx	
A6SG: General-Use communication type	MBDLN25SGxxx	MDDL45SGxxx	MDDL45SGxxx	MDDL55SGxxx	MEDLN83SGxxx	MDDL45SGxxx	MEDLN83SGxxx	
A6SF: Multi-function type	MBDLT25SFxxx	MDDLT45SFxxx	MDDLT45SFxxx	MDDLT55SFxxx	MEDLT83SFxxx	MDDLT45SFxxx	MEDLT83SFxxx	
A6NE: RTEX network standard type	MBDLN25NExxx	MDDL45NExxx	MDDL45NExxx	MDDL55NExxx	MEDLN83NExxx	MDDL45NExxx	MEDLN83NExxx	
A6NF: RTEX network multi-function type	MBDLT25NFxxx	MDDLT45NFxxx	MDDLT45NFxxx	MDDLT55NFxxx	MEDLT83NFxxx	MDDLT45NFxxx	MEDLT83NFxxx	
A6BE/A6BF: EtherCAT network standard type	MBDLN25BExxx	MDDL45BExxx	MDDL45BExxx	MDDL55BExxx	MEDLN83BExxx	MDDL45BExxx	MEDLN83BExxx	
A6BE/A6BF: EtherCAT network multi-function type	MBDLT25BFxxx	MDDLT45BFxxx	MDDLT45BFxxx	MDDLT55BFxxx	MEDLT83BFxxx	MDDLT45BFxxx	MEDLT83BFxxx	
Power voltage	V, Hz	AC200 to 230V +10%, -15%					50/60Hz	
Compatible cable (Panasonic Corporation) *6								
Encoder cable	MFECA0**0EAE	MFECA0**0EPE	MFECA0**0EPE	MFECA0**0EPE	MFECA0**0EPE	MFECA0**0EPE	MFECA0**0EPE	
Motor cable	MFMCA0**0EED	MFMCA0**2FUD	MFMCA0**2FUD	MFMCA0**2FUD	MFMCA0**2FUD	MFMCA0**2FUD	MFMCA0**2FUD	
Brake cable	MFMCB0**0GET							

Note

- The torque is calculated with consideration of the reduction speed ratio and reduction gear efficiency from the rated motor torque and rated rotation speed. This product is also designed under the assumption that it is used for positioning. Contact us when using this product for continuous operation or frequent positioning.
- Set the torque limit of the servo amplifier so that the torques does not exceed the momentary maximum torque of the compact actuator.
- The torque is calculated with consideration of the reduction speed ratio and reduction gear efficiency from the motor brake holding torque.
- The allowable moment will differ depending on the thrust load. Check the allowable moment diagram (page 18).
- When the radial load is applied within dimension b on page 42, use the actuator within the allowable radial load.
- For details on the servomotor, servo amplifier, and cables, see the product catalog or the operation manual issued by Panasonic Corporation.
- The release time shows a value for a DC brake when a surge absorber is used. For details on the surge absorber, see the product catalog issued by Panasonic Corporation.
- Values in parentheses indicate specifications of the type with no brake.
- Value calculated from the rated torque of the motor where the ambient temperature is 20°C. When the ambient temperature is 40°C, the torque will be 75% of the rated torque.

Motor series: MINAS A5

		Solid type				Hollow shaft type			
		AF042N	AF125N	AF380N	AF500N	AF200C	AF320C		
Rated torque *1	Nm	355	1,169	3,329	3,856	1,784	3,002		
Rated output speed *1	min ⁻¹	21.5	19.6	9.2	7.9	12.8	12.7		
Momentary maximum torque *2	Nm	1,029	3,062	9,310	11,567	4,900	7,840		
Momentary maximum output speed	min ⁻¹	32.3	29.4	13.8	11.9	19.2	19.1		
Motor torque limit *2	%	289	261	279	300	274	261		
Brake holding torque (Min.) *3	Nm	456	2,503	5,338	6,182	2,527	3,847		
Single-direction repeatability (Max.)	arc.sec.	60	50	50	50	50	50		
Allowable load inertia moment	kgm ²	51	371	2,026	2,713	303	1,216		
Allowable moment*4	Nm	1,660	3,430	7,050	11,000	8,820	20,580		
Allowable radial load *5	N	12,662	19,804	28,325	40,486	31,455	57,087		
Mass	kg	17	40	77	93	116	163		
Reduction gear	RV precision reduction gear frame number	-	RV-42N	RV-125N	RV-380N	RV-500N	RV-200C	RV-320C	
	Reduction speed ratio	-	93	102.18 (1737/17)	217.86 (1525/7)	252.33 (757/3)	155.96	157	
	Rated torque	Nm	412	1,225	3,724	4,900	1960	3136	
	Rated speed	min ⁻¹	15	15	15	15	15	15	
	Rated service life	hr	6,000	6,000	6,000	6,000	6,000	6,000	
	Backlash	arc.min.	≤1	≤1	≤1	≤1	≤1	≤1	
	Lost motion	arc.min.	≤1	≤1	≤1	≤1	≤1	≤1	
	Spring constant	Nm/arc.min.	113	334	948	1,620	980	1,960	
	Moment rigidity	Nm/arc.min.	840	1,600	5,200	6,850	9,800	12,740	
	Manufacturer	-	Panasonic Corporation						
Motor*6	Representative model	-	MDME102SC	MHME302SC	MDME402SC	MDME402SC	MDME302SC	MDME502SC	
	Rated capacity	kW	1.0	3.0	4.0	4.0	3.0	5.0	
	Rated current	Arms	5.7	16	21.0	21.0	17.4	25.9	
	Momentary maximum current	A(0-p)	24	68	89	89	74	110	
	Brake	Excitation voltage DC	V	24±2.4	24±2.4	24±2.4	24±2.4	24±2.4	24±2.4
		Excitation current DC	A	0.59	1.3	1.3	1.3	0.9	1.3
		Suction time (Max.)	msec	80	80	80	80	110	80
		Release time (Max.) *7	msec	70	25	25	25	50	25
	Encoder	-	Single rotation: 17-bit absolute, Multi-rotation: 16-bit (battery backup)						
	Compatible servo amplifier examples (Panasonic Corporation) *6								
Analog pulse		MDDKT3530xxx	MFDKTA390xxx	MFDKTB3A2xxx	MFDKTB3A2xxx	MFDKTA390xxx	MFDKTB3A2xxx		
RTEX network		MDDHT3530ND1	MFDHTA390ND1	MFDHTB3A2ND1	MFDHTB3A2ND1	MFDHTA390ND1	MFDHTB3A2ND1		
RS485 AE link		MDDHT3530Axx	MFDHTA390Axx	MFDHTB3A2Axx	MFDHTB3A2Axx	MFDHTA390Axx	MFDHTB3A2Axx		
EtherCAT network		MDDHT3530BD1	MFDHTA390BD1	MFDHTB3A2BD1	MFDHTB3A2BD1	MFDHTA390BD1	MFDHTB3A2BD1		
Power voltage	V, Hz	AC200 to 230V +10%, -15% 50/60Hz							
Compatible cable examples (Panasonic Corporation) *6									
Encoder cable		MFECA0**0ESE	MFECA0**0ESE	MFECA0**0ESE	MFECA0**0ESE	MFECA0**0ESE	MFECA0**0ESE		
Motor cable		MFMA0**2FCD	MFMA0**3FCT	MFMA0**3FCT	MFMA0**3FCT	MFMA0**3FCT	MFMA0**3FCT		
Brake cable									

Note

- 1 The torque is calculated with consideration of the reduction speed ratio and reduction gear efficiency from the rated motor torque and rated rotation speed. This product is also designed under the assumption that it is used for positioning. Contact us when using this product for continuous operation or frequent positioning.
- 2 Set the torque limit of the servo amplifier so that the torques does not exceed the momentary maximum torque of the compact actuator.
- 3 The torque is calculated with consideration of the reduction speed ratio and reduction gear efficiency from the motor brake holding torque.
- 4 The allowable moment will differ depending on the thrust load. Check the allowable moment diagram (page 18).
- 5 When the radial load is applied within dimension b on page 42, use the actuator within the allowable radial load.
- 6 For details on the servomotor, servo amplifier, and cables, see the product catalog or the operation manual issued by Panasonic Corporation.
- 7 The release time shows a value for a DC brake when a surge absorber is used. For details on the surge absorber, see the product catalog issued by Panasonic Corporation.

Specifications

Torque range

Motor series: MINAS A6

The momentary maximum torque range and rated torque range of this product are indicated below.

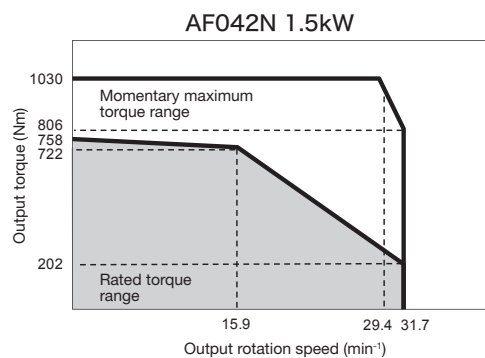
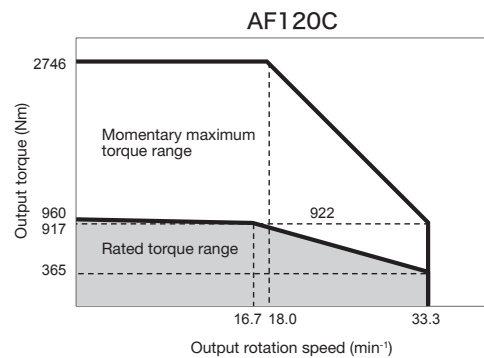
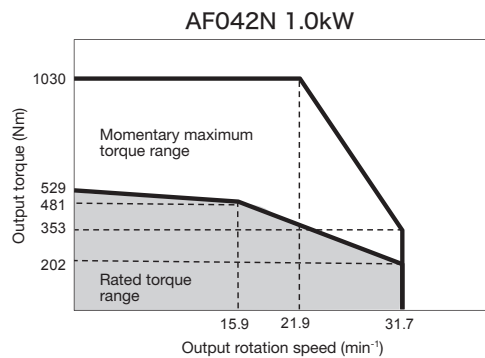
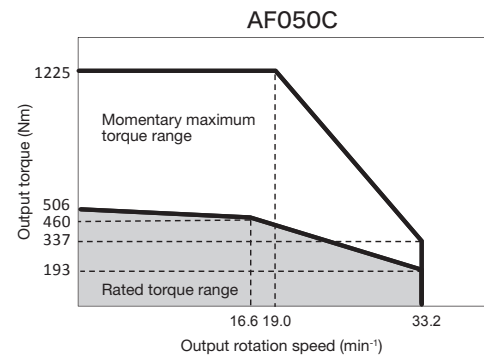
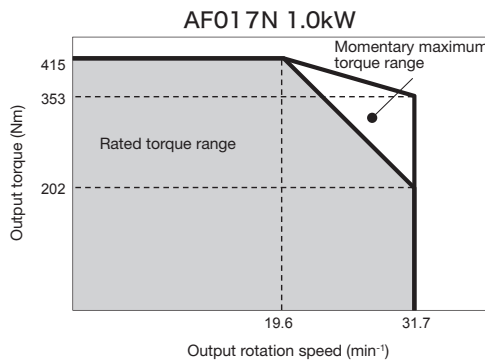
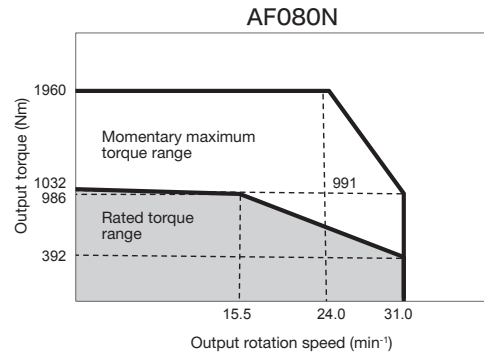
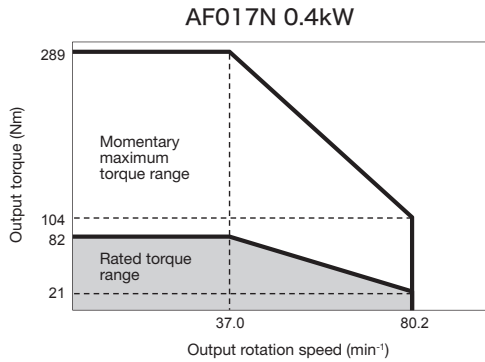

Motor series: MINAS A5

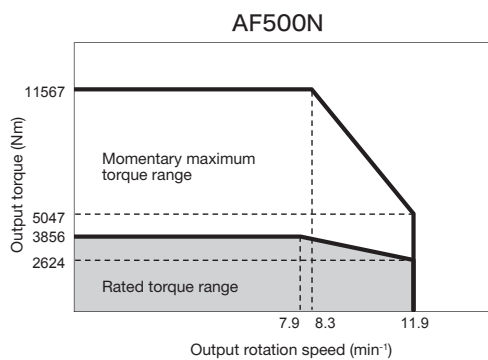
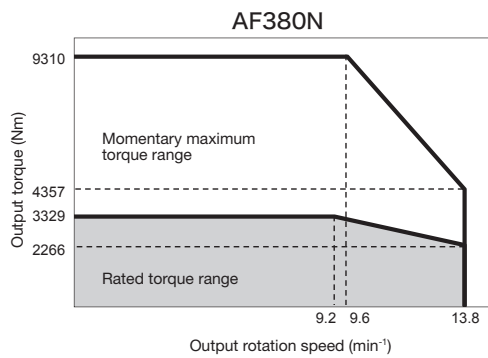
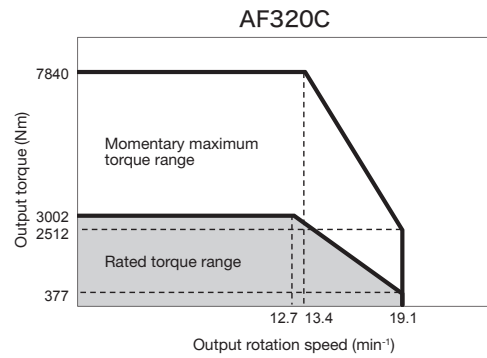
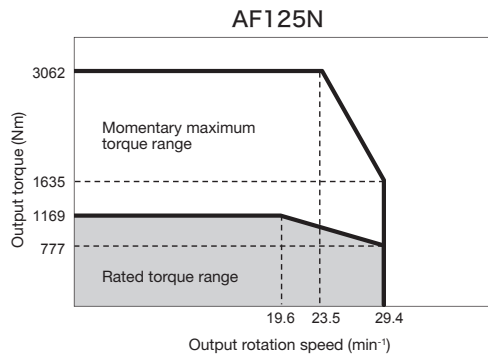
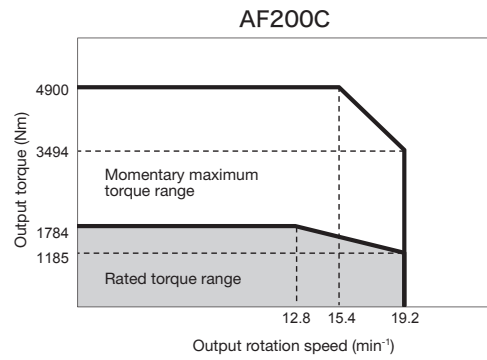
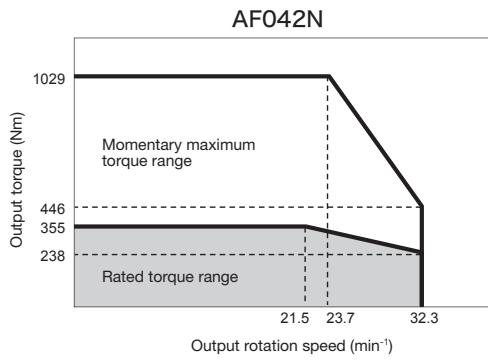

Important

The momentary maximum torque range and rated torque range of this product are shown using values calculated with consideration of the momentary maximum torque range of the motor, rated torque range, reduction speed ratio, reduction gear efficiency, etc.

Specifications

Allowable moment diagram

The allowable moment diagram of this product is shown below.

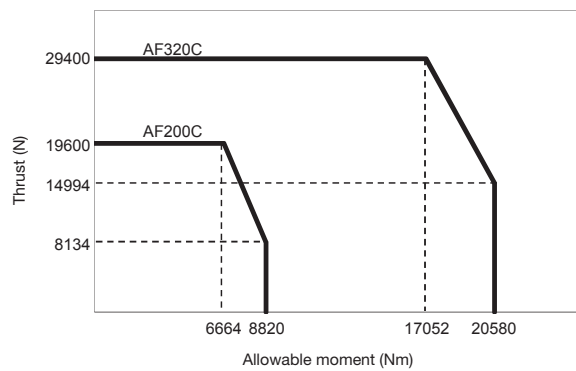
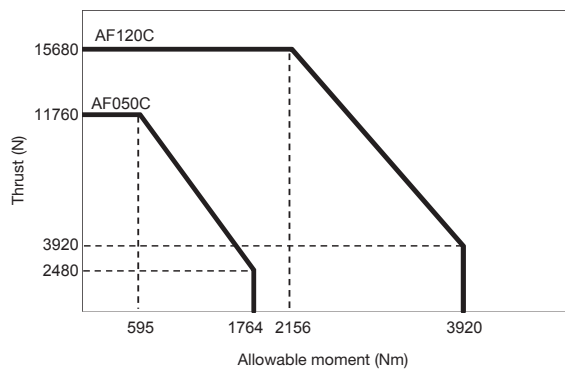
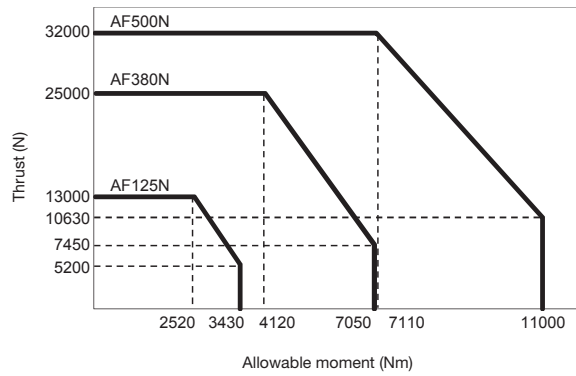
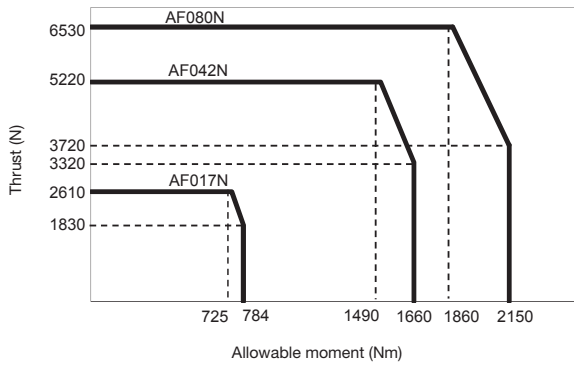

External dimensions

Model code : AF017N081-P01-0B-S0 AF017N081-P01-BB-S0

モータ用コネクタ
プラグ: 172167-1
ピン: 170360-1
(タイコエレクトロニクスジャパン製)
FOR POWER LINE
PLUG: 172167-1
PIN: 170360-1
(Made by TE Connectivity L td.)

ブレーキ用コネクタ(ブレーキ有りのみ)
プラグ: 172165-1
ピン: 170360-1
(タイコエレクトロニクスジャパン製)
FOR BRAKE LINE
(Only for brake type)
PLUG: 172165-1
PIN: 170360-1
(Made by TE Connectivity L td.)

エンコーダ用コネクタ
プラグ: 172169-1(アブソリュート)
ピン: 170359-1
(タイコエレクトロニクスジャパン製)
FOR ENCODER LINE
PLUG: 172169-1(Absolute)
PIN: 170359-1
(Made by TE Connectivity L td.)

8-M8 深さ14 (シャフト固定用)
8-M8 DEPTH 14 (FOR FIXING OUTPUT SHAFT)

PT1/16プラグ (給脂脂ポート) (ケース固定用)
PT1/16 PLUG (FOR LUBRICANT) (FOR FIXING CASE)

加工用ピン穴 FOR MACHINING

塗装範囲 PAINTED AREA

Y部詳細/DETAIL Y

4-φ3深さ4.5 (シールキャップ保持用) (シールキャップ保持用)
4-φ3 DEPTH 4.5 (FOR HOLDING SEAL CAP)

PT1/8プラグ (給脂脂ポート) (給脂脂ポート)
PT1/8 PLUG (FOR LUBRICANT) (FOR LUBRICANT)

X-X断面/SECTION X-X (2箇所/2PLACES)

断面E-E/SECTION E-E

	L	LL
ブレーキ無し WITHOUT MOTOR BRAKE	189	120.3
ブレーキ有り WITH MOTOR BRAKE	218.3	149.6

サーボモータエンコーダ線ピン配置 LAYOUTS OF PINS OF THE ABSOLUTE ENCODER LINE

1	BAT +
2	BAT -
3	FG (Shield)
4	PS
5	PS
6	NC
7	E5V
8	E0V
9	NC

サーボモータブレーキ線ピン配置 (ブレーキ有りのみ) LAYOUTS OF PINS OF THE BRAKE LINE (Only for brake type)

1	ブレーキ (Brake)
2	ブレーキ (Brake)

サーボモータ動力線ピン配置 LAYOUTS OF PINS OF THE POWER LINE

1	U相 (U Phase)
2	V相 (V Phase)
3	W相 (W Phase)
4	アース (Earth)

QR Code:

Model S/N:

S/N・RoHSシール部詳細 DETAIL S/N・RoHS SEAL

速度比 SPEED RATIO

81

Model code : AF380N217-P30-BA-S0

モータ・ブレーキ用コネクタ(品番: JL04V-2E24-11PE-B-R)
(日本航空電子工業株式会社製)
FOR POWER & BRAKE LINE (P/N: JL04V-2E24-11PE-B-R)
(Made by Japan Aviation Electronics Industry, Ltd.)

エンコーダ用コネクタ(品番: N/MS3102A20-29P)
(日本航空電子工業株式会社製)
FOR ABSOLUTE ENCODER LINE (P/N: N/MS3102A20-29P)
(Made by Japan Aviation Electronics Industry, Ltd.)

33-M12 深さ19 (シャフト固定用)
33-M12 DEPTH19
(FOR FIXING OUTPUT SHAFT)

加工用ピン穴
FOR MACHINING

PT1/8 プラグ
(給排脂ポート)

PT1/8 PLUG
(FOR LUBRICANT)

24-φ13 通し
(ケース固定用)

24-φ13 THRU
(FOR FIXING CASE)

33-M12 深さ19 (シャフト固定用)
33-M12 DEPTH19
(FOR FIXING OUTPUT SHAFT)

加工用ピン穴
FOR MACHINING

PT1/8 プラグ
(給排脂ポート)

PT1/8 PLUG
(FOR LUBRICANT)

24-φ13 通し
(ケース固定用)

24-φ13 THRU
(FOR FIXING CASE)

401.15
381.15
290.15
194.15
81.5
52.15
14
16.15
1
13
R1 MAX
HC適用*Oリング G145
HC*O-RING SIZE G145

140
84
2-M10 深さ34.5
(吊タツプ)
2-M10 DEPTH34.5
(FOR HANDLING)

109
D176
PT1/8 プラグ
(給排脂ポート)
PT1/8 PLUG
(FOR LUBRICANT)

吊り上げに使用しないでください
(DO NOT USE FOR HANDLING)

4-φ3 深さ5
(シールキャップ保持用)
4-φ3 DEPTHS
(FOR HOLDING SEAL CAP)

Y部詳細/DETAIL Y

H部詳細/DETAIL H

X-X 断面/SECTION X-X
(2箇所/2PLACES)

サーボモータエンコーダ線ピン配置
LAYOUTS OF PINS OF
THE ABSOLUTE ENCODER LINE

A	NC
B	NC
C	NC
D	NC
E	NC
F	NC
G	E0V
H	E5V
J	FG (Shield)
K	PS
L	PS
M	NC
N	NC
P	NC
R	NC
S	BAT-
T	BAT+

サーボモータ動力線ピン配置
LAYOUTS OF PINS OF
THE POWER & BRAKE LINE

A	ブレーキ (Brake)
B	ブレーキ (Brake)
C	NC
D	U相 (U Phase)
E	V相 (V Phase)
F	W相 (W Phase)
G	アース (Earth)
H	アース (Earth)
I	NC

速度比
SPEED RATIO

1525/7



Technical Information

Considering the use

This product features high precision and high rigidity, however, it is necessary to strictly comply with various restrictions and make appropriate to maximize the product's features. Please read this technical document thoroughly and select and adopt an appropriate model based on the actual operating environment, method, and conditions at your facility.

Export

- When this product is exported from Japan, it may be subject to the export regulations provided in the "Foreign Exchange Order and Export Trade Control Order". Be sure to take sufficient precautions and perform the required export procedures in advance if the final operating party is related to the military or the product is to be used in the manufacture of weapons, etc.

Application

- If failure or malfunction of the product may directly endanger human life or if it is used in units which may injure the human body (atomic energy facilities, space equipment, transportation equipment, medical equipment, safety units, etc.), examination of individual situations is required. Contact our agent or nearest business office in such a case.

Safety measures

- Although this product has been manufactured under strict quality control, a mistake in operation or misuse can result in breakdown or damage, or an accident resulting in injury or death. Be sure to take all appropriate safety measures, such as the installation of independent safeguards.

Product specifications indicated in this catalog

- The specifications indicated in this catalog are based on Nabtesco evaluation methods. This product should only be used after confirming that it is appropriate for the operating conditions of your system.

Operating environment

Use this product in the following environment:

- Location where the ambient temperature is between 0°C and +40°C.
- Location where the humidity is between 20% and 85%RH and no condensation occurs.
- Location where the altitude is less than 1000 m.
- Well-ventilated location

Do not install the actuator at the following locations.

- Locations where a lot of dust is collected.
- Outdoor areas that are directly affected by wind and rain
- Locations near to areas that contain combustible, explosive, or corrosive gases and flammable materials.
- Locations where the performance of the motor can be affected by magnetic fields or vibration.
- Locations where significant vibration or shock is applied.

Note 1: If the required operating environment cannot be established/met, contact us in advance.

2: When using the reduction gear under special conditions (clean room, equipment for food, concentrated alkali, high-pressure steam, etc.), contact our agent or nearest business office in advance.

Maintenance

- The standard replacement time for lubricant is 20,000 hours. However, when operation involves a reduction gear surface temperature above 40°C, the state of degradation of the lubricant should be checked in advance of that and the grease replaced earlier as necessary.

Actuator temperature

- Operate this product while the surface temperature is below the value shown in the following table. There is a possibility of damage (to the product) if the surface temperature exceeds the temperature shown below.
- Reduction gear surface temperature (°C) 60 or less

	Motor series: MINAS A6							Motor series: MINAS A5					
	AF017N (0.4kW)	AF017N (1.0kW)	AF042N (1.0kW)	AF042N (1.5kW)	AF080N	AF050C	AF120C	AF042N	AF125N	AF380N	AF500N	AF200C	AF320C
Surface temperature of motor frame center (°C)	85	80	80	90	90	80	90	70	90	85	85	90	90

Actuator output rotation angle

- When the range of the rotation angle is small (10 degrees or less), the service life of the reduction gear may be reduced due to poor lubrication or the internal parts being subject to a concentrated load.

Note: Contact us in case the rotation angle is 10 degrees or less.

Manuals

- Safety information and detail product instructions are indicated in the operation manual. The operation manual can be downloaded from the following website.

<https://precision.nabtesco.com/>

Glossary

Rated torque

Calculated value with consideration of the motor rated torque, reduction speed ratio, and reduction gear efficiency.

Momentary maximum torque

Calculated value with consideration of the motor torque, reduction speed ratio, and reduction gear efficiency when the motor torque limit is set.

Rated output speed

Calculated value with consideration of the motor rated speed and reduction speed ratio.

Momentary maximum output speed

Calculated value with consideration of the motor maximum speed and reduction speed ratio.

Note: Be aware of cooling conditions so that the surface temperature of the reduction gear does not exceed 60°C during use.

Brake holding torque

Calculated value with consideration of the motor brake torque, reduction speed ratio, and reduction gear efficiency.

Note: The motor built-in brake is for holding the stop state. Do not use the brake to stop a moving load.

Duty ratio

The duty ratio is defined as the ratio of the sum of the total time of acceleration, constant speed, and deceleration to the cycle time of the actuator.

Torsional rigidity, lost motion, backlash

When a torque is applied to the output shaft while the input shaft is fixed, torsion is generated according to the torque value. The torsion can be seen in the hysteresis curves. The value of b/a is referred to as "torsional rigidity". The torsion angle at the mid point of the hysteresis curve width within $\pm 3\%$ of the rated torque is referred to as "lost motion". The torsion angle width of the hysteresis curve at zero torque is referred to as "backlash".

<Hysteresis curve>

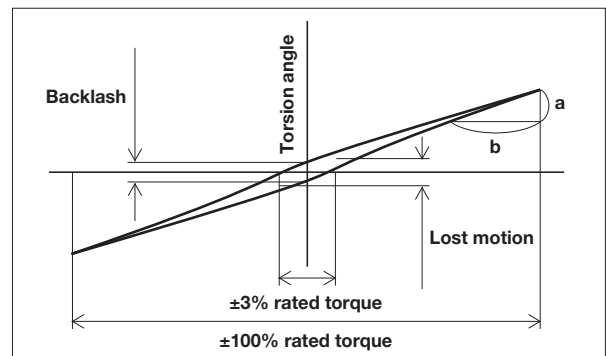

Allowable moment and maximum thrust load

An external moment or thrust load may be applied to the reduction gear during normal operation.

The allowable values of the external moment and external axial load at this time are referred to as "allowable moment" and "maximum thrust load".

Single-direction repeatability

The single-direction repeatability is defined as the difference between the theoretical output angle of rotation (when there are instructions input for an arbitrary rotation angle) and the actual output angle of rotation.

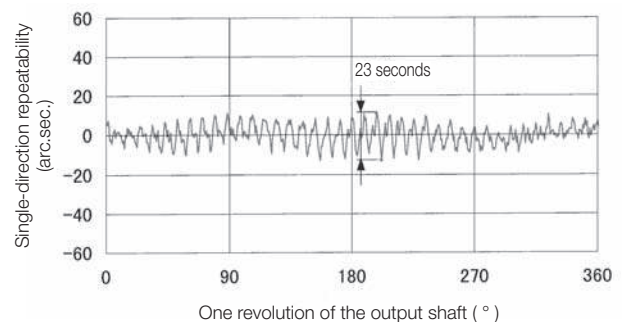

Product selection flowchart

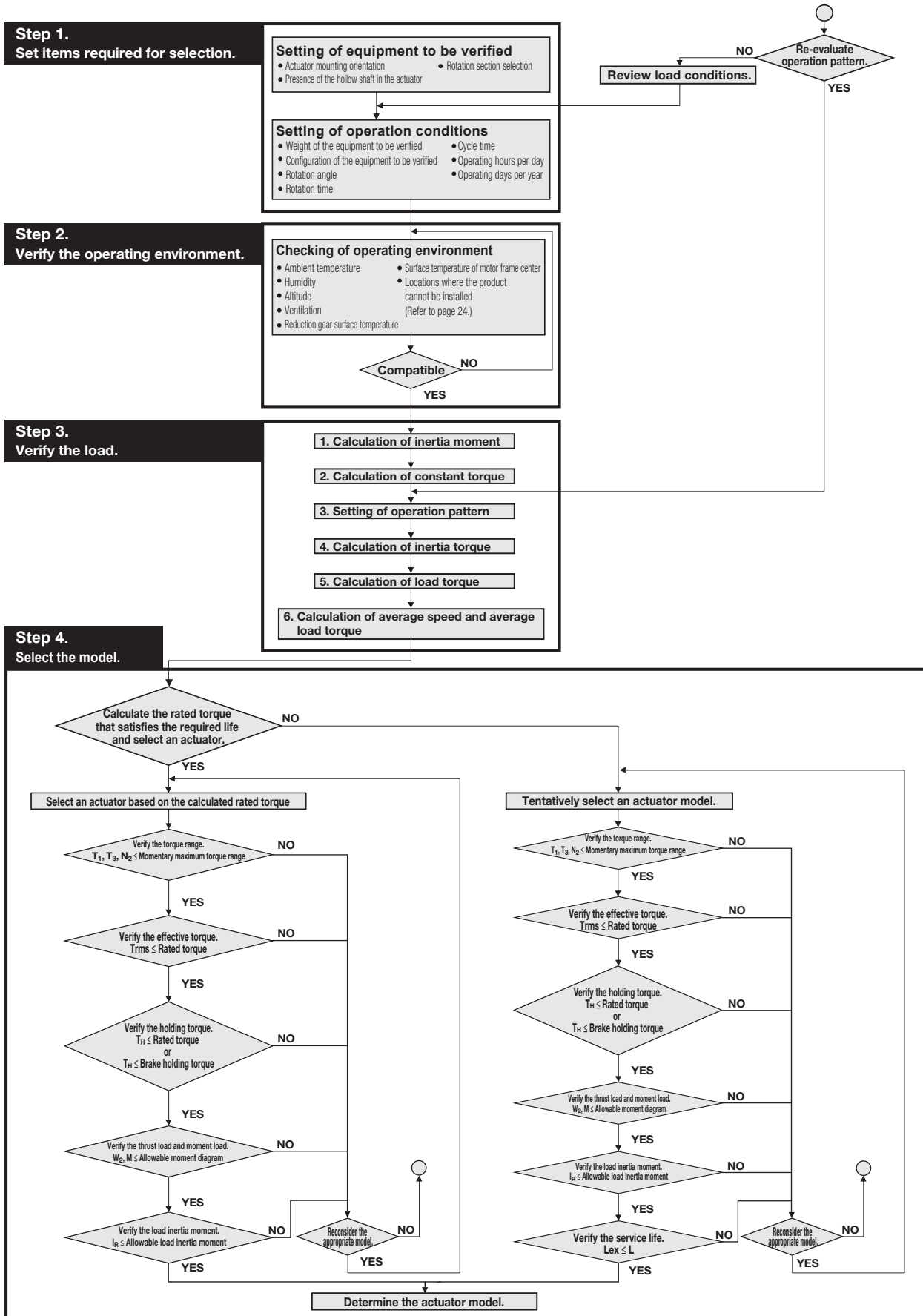

Check that the regenerative energy calculated from the operation pattern is within the capacity of the regenerative resistor for the servo amplifier to be used. (Refer to page 41.)

Model code selection examples

With horizontal rotational transfer

Step 1. Set the items required for selection.

Setting item	Setting
Reduction gear mounting direction	Vertical shaft installation
Presence of the hollow shaft in the actuator	No hollow shaft type (Solid type)
Rotation section selection	Shaft rotation direction when the case is fixed
Equipment weight to be considered	
W _A ——— Disk weight (kg)	180
W _B ——— Work weight (kg)	15 × 4 pieces
Equipment configuration to be considered	
D ₁ ——— Disk: D dimension (mm)	1,200
a ——— Work piece: a dimension (mm)	100
b ——— Work piece: b dimension (mm)	300
D ₂ ——— Work piece: P.C.D. (mm)	1,000
Operation conditions	
θ ——— Rotation angle (°)*1	180
[t ₁ +t ₂ +t ₃] ——— Rotation time (s)	2.0
[t ₄] ——— Stop time (s)	5
Q ₁ ——— Equipment operation hours per day (hours/day)	24
Q ₂ ——— Equipment operation days per year (days/year)	365

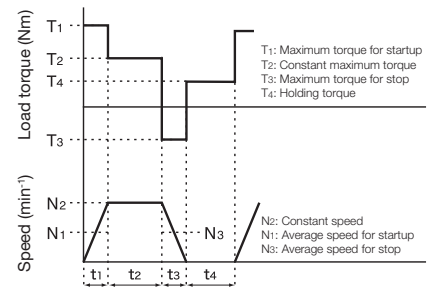
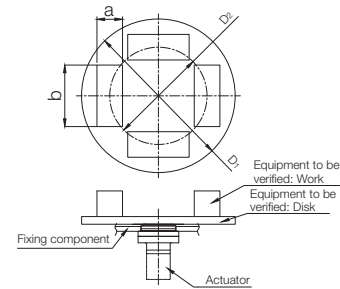

*1. When the range of the rotation angle is small (10 degrees or less), the rated life of the reduction gear may be reduced due to poor lubrication or internal parts being subject to a concentrated load.

Step 2. Verify the operating environment.

Checkpoint	Standard value
Ambient temperature (°C)	0 to 40
Reduction gear surface temperature (°C)	60 or less

	Motor series: MINAS A6							Motor series: MINAS A5					
	AF017N (0.4kW)	AF017N (1.0kW)	AF042N (1.0kW)	AF042N (1.5kW)	AF080N	AF050C	AF120C	AF042N	AF125N	AF380N	AF500N	AF200C	AF320C
Surface temperature of motor frame center (°C)	85	80	80	90	90	80	90	70	90	85	85	90	90

Note: Refer to "Operating environment" on p. 32 for values other than those listed above.

Step 3-1. Verify the load.

Setting item	Calculation formula	Selection examples
(1) Calculate the inertia moment based the calculation formula on page 38.		
I _R Load inertia moment (kgm ²)	$I_{R1} = \frac{W_A \times \left(\frac{D_1}{2 \times 1,000}\right)^2}{2}$ $I_{R2} = \left[\frac{W_B}{12} \left\{ \left(\frac{a}{1,000}\right)^2 + \left(\frac{b}{1,000}\right)^2 \right\} + W_B \times \left(\frac{D_2}{2 \times 1,000}\right)^2 \right] \times n$ <p>I_{R1} = Disk inertia moment I_{R2} = Work inertia I_R = I_{R1} + I_{R2} n = Number of work pieces</p>	$I_{R1} = \frac{180 \times \left(\frac{1,200}{2 \times 1,000}\right)^2}{2}$ $= 32.4 \text{ (kgm}^2\text{)}$ $I_{R2} = \left[\frac{15}{12} \left\{ \left(\frac{100}{1,000}\right)^2 + \left(\frac{300}{1,000}\right)^2 \right\} + 15 \times \left(\frac{1,000}{2 \times 1,000}\right)^2 \right] \times 4$ $= 15.5 \text{ (kgm}^2\text{)}$ $I_R = 32.4 + 15.5$ $= 47.9 \text{ (kgm}^2\text{)}$
(2) Examine the constant torque.		
T _R Constant torque (Nm)	$T_R = (W_A + W_B) \times 9.8 \times \frac{D_n}{2 \times 1,000} \times \mu$ <p>μ = Friction factor</p> <p>Note: Use 0.015 for this example as the load is applied to the bearing of the RD2 precision reduction gear.</p> <p>D_n = Rolling diameter: Use the pilot diameter which is almost equivalent to the rolling diameter in this selection calculation.</p> <p>Note: If the actuator model is not determined, select the maximum value for D_n. Solid type: 284 (mm), Hollow shaft type: 440 (mm)</p>	$T_R = (180 + 15 \times 4) \times 9.8 \times \frac{284}{2 \times 1,000} \times 0.015$ $= 5.0 \text{ (Nm)}$
(3) Verify the load (horizontal direction).		
T _H Holding torque (Nm)	0 for horizontal rotational transfer	T _H = 0

Step 3-2: Proceed to p. 37.

Model code selection examples

With vertical rotational transfer

Step 1. Set the items required for selection.

Setting item	Setting
Reduction gear mounting direction	Horizontal shaft installation
Presence of the hollow shaft in the actuator	No hollow shaft type (Solid type)
Rotation section selection	Shaft rotation direction when the case is fixed
Equipment weight to be considered	
W_C — Mounted work weight (kg)	490
Equipment configuration to be considered	
a — a dimension (mm)	500
b — b dimension (mm)	500
R — R dimension (mm)	320
α — Angle α (°)	80
Operation conditions	
θ — Rotation angle (°)*1	90
$[t_1+t_2+t_3]$ — Rotation time (s)	1.5
$[t_4]$ — Stop time (s)	18.5
Q_1 — Equipment operation hours per day (hours/day)	24
Q_2 — Equipment operation days per year (days/year)	365

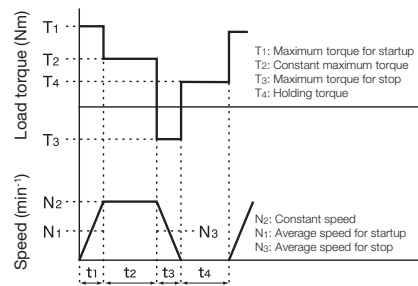
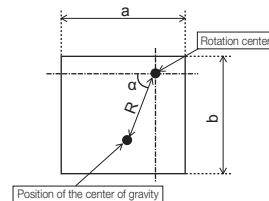
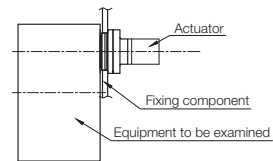

*1. When the range of the rotation angle is small (10 degrees or less), the rated life of the reduction gear may be reduced due to poor lubrication or internal parts being subject to a concentrated load.

Step 2. Verify the operating environment.

Checkpoint	Standard value
Ambient temperature (°C)	0 to 40
Reduction gear surface temperature (°C)	60 or less

	Motor series: MINAS A6							Motor series: MINAS A5					
	AF017N (0.4kW)	AF017N (1.0kW)	AF042N (1.0kW)	AF042N (1.5kW)	AF080N	AF050C	AF120C	AF042N	AF125N	AF380N	AF500N	AF200C	AF320C
Surface temperature of motor frame center (°C)	85	80	80	90	90	80	90	70	90	85	85	90	90

Note: Refer to "Operating environment" on p. 32 for values other than those listed above.

Step 3-1. Verify the load.

Setting item	Calculation formula	Selection examples
(1) Calculate the inertia moment based the calculation formula on page 38.		
I_R Load inertia moment (kgm ²)	$I_R = \frac{W_C}{12} \times \left[\left(\frac{a}{1,000} \right)^2 + \left(\frac{b}{1,000} \right)^2 \right] + W_C \times \left(\frac{R}{1,000} \right)^2$	$I_R = \frac{490}{12} \times \left[\left(\frac{500}{1,000} \right)^2 + \left(\frac{500}{1,000} \right)^2 \right] + 490 \times \left(\frac{320}{1,000} \right)^2 = 70.6(\text{kgm}^2)$
(2) Examine the constant torque.		
T_R Constant torque (Nm)	$T_R = W_C \times 9.8 \times \frac{R}{1,000}$	$T_R = 490 \times 9.8 \times \frac{320}{1,000} = 1,537(\text{Nm})$
(3) Verify the load (vertical direction).		
T_H Holding torque (Nm)	$T_H = W_C \times 9.8 \times \frac{R}{1,000} \times \cos\alpha$	$T_H = 490 \times 9.8 \times \frac{320}{1,000} \times \cos 80 = 267(\text{Nm})$

Step 3-2: Proceed to p. 37.

(Refer to "With horizontal rotational transfer" for selection examples.)

Step 3-2. Set items required for selection

Setting item	Calculation formula	Selection examples (With horizontal rotational transfer)
(3) Set the acceleration/deceleration time, constant-speed operation time, and output speed.		
t ₁ — Acceleration time (s)	<ul style="list-style-type: none"> The operation pattern does not need to be verified if it is already set. If the operation pattern has not been determined, use the following formula to calculate the reference operation pattern. $N_2 = \frac{\theta}{3 \times (t_1 + 2 \times t_2 + t_3)}$ <p>Note: 1. Enter a value that satisfies $t_1 = t_2 \leq (t_1 + t_2 + t_3)/2$. Note: 2. Assume that t_1 and t_3 are the same.</p>	Assume that: t ₁ = t ₃ = 0.5 (s), t ₂ = 1.0 (s)
t ₂ — Constant-speed operation time (s)		$N_2 = \frac{180}{3 \times (0.5 + 2 \times 1.0 + 0.5)}$ = 20 (min ⁻¹)
t ₃ — Deceleration time (s)		
N ₂ — Constant speed (min ⁻¹)		
N ₁ — Average speed for startup (min ⁻¹)	$N_1 = \frac{N_2}{2}$	$N_1 = \frac{20}{2} = 10$ (min ⁻¹)
N ₃ — Average speed for stop (min ⁻¹)	$N_3 = \frac{N_2}{2}$	$N_3 = \frac{20}{2} = 10$ (min ⁻¹)
(4) Calculate the inertia torque for acceleration/deceleration.		
T _A — Inertia torque for acceleration (Nm)	$T_A = \left\{ \frac{I_R \times (N_2 - 0)}{t_1} \right\} \times \frac{2\pi}{60}$	$T_A = \left\{ \frac{47.9 \times (20 - 0)}{0.5} \right\} \times \frac{2\pi}{60}$ = 200.6 (Nm)
T _D — Inertia torque for deceleration (Nm)	$T_D = \left\{ \frac{I_R \times (0 - N_2)}{t_3} \right\} \times \frac{2\pi}{60}$	$T_D = \left\{ \frac{47.9 \times (0 - 20)}{0.5} \right\} \times \frac{2\pi}{60}$ = -200.6 (Nm)
(5) Calculate the load torque for acceleration/deceleration.		
T ₁ — Maximum torque for startup (Nm)	T ₁ = T _A + T _R T _R : Constant torque With horizontal rotational transfer Refer to page 35 With vertical rotational transfer Refer to page 36	T ₁ = 200.6 + 5.0 = 205.6 (Nm)
T ₂ — Constant maximum torque (Nm)	T ₂ = T _R	T ₂ = 5.0 (Nm)
T ₃ — Maximum torque for stop (Nm)	T ₁ = T _A + T _R T _R : Constant torque With horizontal rotational transfer Refer to page 35 With vertical rotational transfer Refer to page 36	T ₃ = -200.6 + 5.0 = 195.6 (Nm)
T ₄ — Holding torque (Nm)	T ₄ = T _H	T ₄ = 0
(6)-1 Calculate the average speed.		
N _m — Average speed (min ⁻¹)	$N_m = \frac{t_1 \times N_1 + t_2 \times N_2 + t_3 \times N_3}{t_1 + t_2 + t_3}$	$N_m = \frac{0.5 \times 10 + 1.0 \times 20 + 0.5 \times 10}{0.5 + 1.0 + 0.5}$ = 15 (min ⁻¹)
(6)-2 Calculate the average load torque.		
T _m — Average load torque (Nm)	$T_m = \sqrt[10]{\frac{t_1 \times N_1 \times T_1^{\frac{10}{3}} + t_2 \times N_2 \times T_2^{\frac{10}{3}} + t_3 \times N_3 \times T_3^{\frac{10}{3}}}{t_1 \times N_1 + t_2 \times N_2 + t_3 \times N_3}}$	$T_m = \sqrt[10]{\frac{0.5 \times 10 \times 205.6^{\frac{10}{3}} + 1.0 \times 20 \times 5.0^{\frac{10}{3}} + 0.5 \times 10 \times 195.6^{\frac{10}{3}}}{0.5 \times 10 + 1.0 \times 20 + 0.5 \times 10}}$ = 144.4 (Nm)

Go to page 38 if the actuator model is verified based on the required life.

Go to page 40 if the service life is verified based on the actuator model.



Model code selection examples

Step 4. Select an actuator

Actuator selection method (1) Calculate the required torque based on the load conditions and required life and select an actuator.

Setting/verification item	Calculation formula	Selection examples (With horizontal rotational transfer)
(1) Calculate the rated torque for the reduction gear that satisfies the required life.		
L_{ex} Required life (year)	Based on the operation conditions	10 years
Q_{1cy} Number of cycles per day (times)	$Q_{1cy} = \frac{Q_1 \times 60 \times 60}{t_1 + t_2 + t_3 + t_4}$	$Q_{1cy} = \frac{24 \times 60 \times 60}{0.5 + 1 + 0.5 + 5}$ = 12,343(times)
Q_3 Operating hours of actuator per day (h)	$Q_3 = \frac{Q_{1cy} \times (t_1 + t_2 + t_3)}{60 \times 60}$	$Q_3 = \frac{12,343 \times (0.5 + 1.0 + 0.5)}{60 \times 60}$ = 6.9 (h)
Q_4 Operating hours of actuator per year (h)	$Q_4 = Q_3 \times Q_2$	$Q_4 = 6.9 \times 365$ = 2,519 (h)
L_{hour} Actuator service life (h)	$L_{hour} = Q_4 \times L_{ex}$	$L_{hour} = 2,519 \times 10$ = 25,190 (h)
$T_{O'}$ Reduction gear rated torque that satisfies the required life (Nm)	$T_{O'} = T_m \times \left(\frac{10}{3}\right) \sqrt{\frac{L_{hour}}{\text{Reduction gear rated service life}} \times \frac{N_m}{\text{Reduction gear rated output speed}}}$ Note Reduction gear rated service life = 6,000 (h) Reduction gear rated output speed = 15 (min ⁻¹)	$T_{O'} = 144.4 \times \left(\frac{10}{3}\right) \sqrt{\frac{25,190}{6,000} \times \frac{15}{15}}$ = 222.0 (Nm)
(2) Tentatively select a reduction gear model based on the calculated rated torque.		
Tentative selection of the actuator	Select an actuator for which the rated torque of the reduction gear [T_O] is equal to or smaller than the rated torque of the reduction gear that satisfies the required life. Note Reduction gear rated torque: See pages 14 and 15.	Tentatively select AF042N, which satisfies the following formula. [T_O] 222.0 (Nm) ≤ Reduction gear rated torque 412 (Nm)
(3) Verify the torque range.		
Verification of the torque range	Check that the load torque and operation pattern are within the momentary maximum torque range. Momentary maximum torque range: See page 16.	They are within the momentary maximum torque range. There is no problem with the tentatively selected model.
(4) Verify the effective torque.		
Verify the effective torque.	Check that the effective torque [T_{rms}] is equal to or smaller than the rated torque. $T_{rms} = \sqrt{\frac{t_1 \times T_1^2 + t_2 \times T_2^2 + t_3 \times T_3^2 + t_4 \times T_4^2}{t_1 + t_2 + t_3 + t_4}}$	$T_{rms} = \sqrt{\frac{0.5 \times 205.6^2 + 1.0 \times 5.0^2 + 0.5 \times 195.6^2 + 5 \times 0^2}{0.5 + 1.0 + 0.5 + 5}}$ = 75.9 (Nm) [T_{rms}] 75.9 ≤ Rated torque 355 (Nm) There is no problem with the tentatively selected model.
(5) Verify the holding torque.		
Verification of the holding torque	If the servo lock is used for holding, check that the holding torque [T_H] is equal to or smaller than the rated torque. If the motor built-in brake is used for holding, check that the holding torque [T_H] is equal to or smaller than the brake holding torque.	[T_H] 0 (Nm) ≤ Rated torque 355 (Nm) There is no problem with the tentatively selected model.

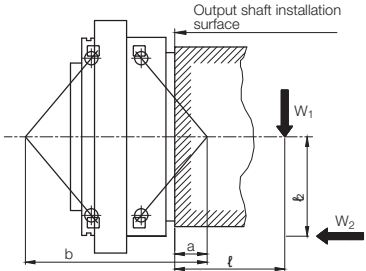
Actuator selection method (1) Calculate the required torque based on the load conditions and required life and select an actuator.

Setting/verification item	Calculation formula	Selection examples (With horizontal rotational transfer)
(6) Verify the thrust load and moment load.		
W_1 — Radial load (N) ℓ — Distance to the point of radial load application (mm) W_2 — Thrust load (N) ℓ_2 — Distance to the point of thrust load application (mm) M — Moment load (Nm)	 $M = \frac{W_1 \times (\ell + b - a) + W_2 \times \ell_2}{1,000}$ a,b: Refer to the calculation of the tilt angle on page 42.	0 (N) 0 (mm) In this example, $W_2 = W_A + W_B = (180 + 20 \times 4) \times 9.8$ $= 2,352 \text{ (N)}$ Note W_A, W_B : Refer to page 35. 0 (mm) (As the workpiece center is located on the rotation axis) $M = \frac{0 \times (0 + 131.1 - 29) + 2,352 \times 0}{1,000}$ $= 0 \text{ (Nm)}$
Verify the thrust load and moment load	Check that the thrust load and moment load are within the range in the allowable moment diagram on page 18. When radial load W_1 is applied within dimension b , use the reduction gear within the allowable radial load. If the tentatively selected reduction gear is outside of the specifications, change the reduction gear model.	For this example, Thrust load $[W_2] = 2,352 \text{ (N)}$ Moment load $[M] = 0 \text{ (Nm)}$ As the above values are within the range in the allowable moment diagram. There is no problem with the tentatively selected model.
(7) Verify the load inertia moment.		
Verify the load inertia moment.	Check that the load inertia moment $[I_L]$ is equal to or smaller than the allowable load inertial moment.	$[I_L] 47.9 \text{ (kgm}^2) \leq \text{Allowable load inertia moment } 51 \text{ (kgm}^2)$ There is no problem with the tentatively selected model.
		
Select the actuator model that satisfies all the conditions of the above verification items.		Based on the above verification result, AF042N is selected.

Actuator selection method (2) Tentatively select an actuator model and evaluate the service life.

Setting/verification item	Calculation formula	Selection examples (With horizontal rotational transfer)
(1) Tentatively select a desired actuator model.		
Tentative selection of the actuator	Select a desired actuator model.	For example, tentatively select AF042N.
(2) Verify the torque range.		
Verification of the torque range	Check that the load torque and operation pattern are within the momentary maximum torque range. Momentary maximum torque range: See page 16.	They are within the momentary maximum torque range. There is no problem with the tentatively selected model.
(3) Verify the effective torque.		
Verify the effective torque.	Check that the effective torque $[T_{rms}]$ is equal to or smaller than the rated torque. $T_{rms} = \sqrt{\frac{t_1 \times T_1^2 + t_2 \times T_2^2 + t_3 \times T_3^2 + t_4 \times T_4^2}{t_1 + t_2 + t_3 + t_4}}$	$T_{rms} = \sqrt{\frac{0.5 \times 205.6^2 + 1.0 \times 5.0^2 + 0.5 \times 195.6^2 + 5 \times 0^2}{0.5 + 1.0 + 0.5 + 5}}$ $= 75.9 \text{ (Nm)}$ $[T_{rms}] 75.9 \leq \text{Rated torque } 355 \text{ (Nm)}$ There is no problem with the tentatively selected model.
(4) Verify the holding torque.		
Verification of the holding torque	If the servo lock is used for holding, check that the holding torque $[T_H]$ is equal to or smaller than the rated torque. If the motor built-in brake is used for holding, check that the holding torque $[T_H]$ is equal to or smaller than the brake holding torque.	$[T_H] 0 \text{ (Nm)} \leq \text{Rated torque } 355 \text{ (Nm)}$ There is no problem with the tentatively selected model.

Model code selection examples

Reduction gear selection method (2): Tentatively select a reduction gear model and evaluate the service life.

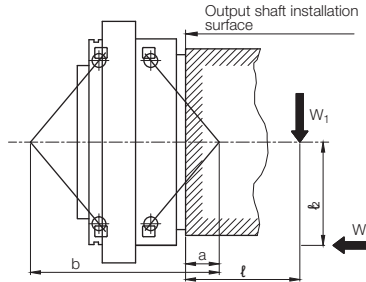
Setting/verification item	Calculation formula	Selection examples (With horizontal rotational transfer)
(1) Verify the thrust load and moment load.		
W_1 — Radial load (N) ℓ — Distance to the point of radial load application (mm) W_2 — Thrust load (N) ℓ_2 — Distance to the point of thrust load application (mm) M — Moment load (Nm)	 $M = \frac{W_1 \times (\ell + b - a) + W_2 \times \ell_2}{1,000}$ <p>a, b: Refer to the calculation of the tilt angle on page 42.</p>	0 (N) 0 (mm) $W_2 = W_A + W_B = (180 + 15 \times 4) \times 9.8 = 2,352$ (N) 0 (mm) (As the workpiece center is located on the rotation axis) AF042N As dimension a = 29 (mm) and dimension b = 131.1 (mm): $M = \frac{0 \times (0 + 131.1 - 29) + 2,352 \times 0}{1,000} = 0$ (Nm)
Verify the thrust load and moment load	Check that the thrust load and moment load are within the range in the allowable moment diagram on page 18. When radial load W_1 is applied within dimension b, use the reduction gear within the allowable radial load. If the tentatively selected reduction gear is outside of the specifications, change the reduction gear model.	For this example, Thrust load [W_2] = 2,352 (N) Moment load [M] = 0 (N) As the above values are within the range in the allowable moment diagram. There is no problem with the tentatively selected model.
(2) Verify the load inertia moment.		
Verify the load inertia moment.	Check that the load inertia moment [I_L] is equal to or smaller than the allowable load inertial moment.	I_L 47.9 (kgm ²) ≤ Allowable load inertia moment 51 (kgm ²) There is no problem with the tentatively selected model.
(3) Verify the reduction gear service life.		
L_h — Life (h)	$L_h = \text{Reduction gear rated service life} \times \frac{\text{Reduction gear rated speed}}{N_m} \times \left(\frac{\text{Reduction gear rated torque}}{T_m} \right)^{\frac{10}{3}}$ Reduction gear rated service life=6,000 (h) Reduction gear rated speed=15 (min ⁻¹) Note Reduction gear rated torque: See pages 14 and 15.	$L_h = 6,000 \times \frac{15}{15} \times \left(\frac{412}{144.4} \right)^{\frac{10}{3}} = 197,660$ (h)
Q_{1cy} — Number of cycles per day (times)	$Q_{1cy} = \frac{Q_1 \times 60 \times 60}{t_1 + t_2 + t_3 + t_4}$	$Q_{1cy} = \frac{24 \times 60 \times 60}{0.5 + 1.0 + 0.5 + 5} = 12,343$ (times)
Q_3 — Operating hours per day (h)	$Q_3 = \frac{Q_{1cy} \times (t_1 + t_2 + t_3)}{60 \times 60}$	$Q_3 = \frac{12,343 \times (0.5 + 1.0 + 0.5)}{60 \times 60} = 6.9$ (h)
Q_4 — Operating hours per year (h)	$Q_4 = Q_3 \times Q_2$	$Q_4 = 6.9 \times 365 = 2519$ (h)
L_{year} — Reduction gear service life (year)	$L_{year} = \frac{L_h}{Q_4}$	$L_{year} = \frac{197,660}{2,519} = 78.5$ (year)
L_{ex} — Required life (year)	Based on the operation conditions	10 years
Verification of the service life	Check the following condition: [L_{ex}] is equal to or less than [L_{year}] If the tentatively selected reduction gear is outside of the specifications, change the reduction gear model.	$[L_{ex}]$ 10 (year) ≤ [L_{year}] 78.5 (year) There is no problem with the tentatively selected model.
<p style="text-align: center;">↓</p> Select the actuator model that satisfies all the conditions of the above verification items.		Based on the above verification result, AF042N is selected.

Servo amplifier regenerative resistor capacity

The regenerative energy generated when the actuator decelerates may return to the servo amplifier, depending on the load conditions and operational pattern. Check that the regenerative energy is within the capacity of regenerative resistor for the servo amplifier to be used. If the regenerative energy exceeds the resistor's capacity, consider using an external regenerative resistor.

For the regenerative resistor capacity and selection of an external regenerative resistor, you can check the Panasonic Corporation motor selection software (see URL below).

<http://www3.panasonic.biz/ac/j/motor/fa-motor/ac-servo/mselect/index.jsp>

Contact Panasonic Corporation if you have any questions.

If you use the Panasonic Corporation motor selection software, select the following motors according to the model of this product.

Motor series: MINAS A6

Model	Motor
AF017N (0.4kW)	MHMF (IP65)
AF017N (1.0kW)	MDMF (IP67)
AF042N (1.0kW)	MDMF (IP67)
AF042N (1.5kW)	MDMF (IP67)
AF080N	MDMF (IP67)
AF050C	MDMF (IP67)
AF120C	MDMF (IP67)

Motor series: MINAS A5

Model	Motor
AF042N	MDME (IP65)
AF125N	MHME (IP65)
AF380N	MDME (IP65)
AF500N	MDME (IP65)
AF200C	MDME (IP65)
AF320C	MDME (IP65)

Technical data

Calculation of tilt angle and torsion angle

Calculation of tilt angle

When a load moment occurs with an external load applied, the output shaft will tilt in proportion to the load moment (If l_3 is larger than b)
The moment rigidity indicates the rigidity of the main bearing, and it is represented by the load moment value required for tilting the main bearing by 1 arc.min.

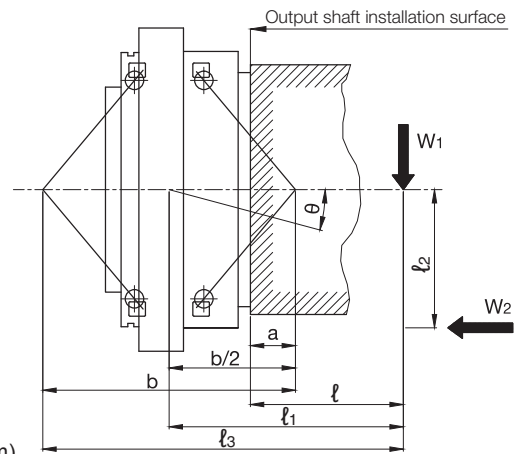

$$\theta = \frac{W_1 l_1 + W_2 l_2}{M_1 \times 10^3}$$

θ : Tilt angle of the output shaft (arc.min.)
 M_1 : Moment rigidity (Nm/arc.min.)
 W_1, W_2 : Load (N)
 l_1, l_2 : Distance to the point of load application (mm)
 l_1 : $l + \frac{b}{2} - a$
 l : Distance from the output shaft installation surface to the point of load application (mm)

Model	Moment rigidity (central value) (Nm/arc.min.)	Dimensions	
		a	b
AF017N	515	22.1	112.4
AF042N	840	29	131.1
AF080N	1,190	33.8	151.8
AF125N	1,600	41.6	173.2
AF380N	5,200	48.7	248.9
AF500N	6,850	56.3	271.7

Model	Moment rigidity (central value) (Nm/arc.min.)	Dimensions	
		a	b
AF050C	1,960	50.4	187.1
AF120C	4,263	60.6	209.6
AF200C	9,800	76	280.4
AF320C	12,740	114.5	360.5

Calculation of torsion angle

Calculate the torsion angle when the torque is applied in a single direction, using an example of AF125N.

1) When the load torque is 30 Nm.....Torsion angle (ST_1)

- When the load torque is 3% or less of the rated torque

$$ST_1 = \frac{\text{Load torque}}{\text{3\% of reduction gear rated torque}} \times \frac{\text{Lost motion}}{2} = \frac{30}{36.8} \times \frac{1}{2} = 0.40 \text{ (arc.min.) or less}$$

2) When the load torque is 1,300 Nm.....Torsion angle (ST_2)

- When the load torque is more than 3% of the rated torque

$$ST_2 = \frac{\text{Lost motion}}{2} + \frac{\text{Load torque} - \text{3\% of reduction gear rated torque}}{\text{Torsional rigidity}} = \frac{1}{2} + \frac{1,300 - 36.8}{334} = 4.28 \text{ (arc.min.) or less}$$

Note: The torsion angles that are calculated above are for a single reduction gear.

Model	Torsional rigidity (central value) (Nm/arc.min.)	Lost motion		Backlash (arc.min.)
		Lost motion (arc.min.)	Measured torque (Nm)	
AF017N	36	1	±5.0	1
AF042N	113	1	±12.4	1
AF080N	212	1	±23.5	1
AF125N	334	1	±36.8	1
AF380N	948	1	±112.0	1
AF500N	1,620	1	±147.0	1

Model	Torsional rigidity (central value) (Nm/arc.min.)	Lost motion		Backlash (arc.min.)
		Lost motion (arc.min.)	Measured torque (Nm)	
AF050C	255	1	±14.7	1
AF120C	588	1	±35.3	1
AF200C	980	1	±58.8	1
AF320C	1,960	1	±94.1	1

Design points

Design of actuator installation components

Installation of the actuator and mounting it to the output shaft

When installing the actuator, use hexagon socket head cap screws and tighten them at the torque specified below. The use of Serrated lock washers is recommended to prevent the hexagon socket head cap screws from loosening and to protect the seat surface from flaws.

• Hexagon socket head cap screw

<Bolt tightening torque and tightening force>

Model	Bolt connective component	Number of bolts - Size	Tightening torque (Nm)	Allowable transmission torque (Nm)	Bolt specification
AF017N	Shaft	8-M8	37.2±1.86	934	Hexagon socket head cap screw JIS B 1176 : 2006 Strength class JIS B 1051 : 2000 12.9 Thread JIS B 0209 : 2001 6g
	Case	16-M5	9.01±0.49	1,380	
AF042N	Shaft	9-M10	73.5±3.43	2,185	
	Case	16-M6	15.6±0.78	2,341	
AF080N	Shaft	24-M8	37.2±1.86	4,399	
	Case	16-M8	37.2±1.86	5,032	
AF125N	Shaft	21-M10	73.5±3.43	6,872	
	Case	16-M10	73.5±3.43	9,322	
AF380N	Shaft	33-M12	129±6.37	25,787	
	Case	24-M12	129±6.37	27,374	
AF500N	Shaft	33-M12	129±6.37	30,002	
	Case	28-M12	129±6.37	35,292	
AF050C	Shaft	9-M10	73.5±3.43	3,419	
	Case	12-M8	37.2±1.86	5,305	
AF120C	Shaft	12-M12	129±6.37	7,934	
	Case	14-M10	73.5±3.43	13,984	
AF200C	Shaft	9-M16	319±15.9	13,542	
	Case	16-M12	129±6.37	22,878	
AF320C	Shaft	15-M16	319±15.9	34,203	
	Case	12-M16	319±15.9	41,137	

Note: 1. The tightening torque values listed are for steel or cast iron material.

2. If softer material, such as aluminum or stainless steel, is used, limit the tightening torque. Also take the transmission torque and load moment into due consideration.

<Calculation of allowable transmission torque of bolts>

$T = F \times \mu \times \frac{D}{2 \times 1,000} \times n$	T	Allowable transmission torque by tightening bolt (Nm)
	F	Bolt tightening force (N)
	D	Bolt mounting P.C.D. (mm)
	μ	Friction factor μ=0.15: When lubricant remains on the mating face. μ=0.20: When lubricant is removed from the mating face.
	n	Number of bolts (pcs.)

• Serrated lock washer for hexagon socket head cap screw

Name: Belleville spring washer (made by Heiwa Hatsujyo Industry Co., Ltd.)

Corporation symbol: CDW-H

CDW-L (Only for M5)

Material: S50C to S70C

Hardness: HRC40 to 48

(Unit: mm)

Nominal size	ID and OD of Belleville spring washer		t	H
	Ød	ØD		
5	5.25	8.5	0.6	0.85
6	6.4	10	1.0	1.25
8	8.4	13	1.2	1.55
10	10.6	16	1.5	1.9
12	12.6	18	1.8	2.2
16	16.9	24	2.3	2.8

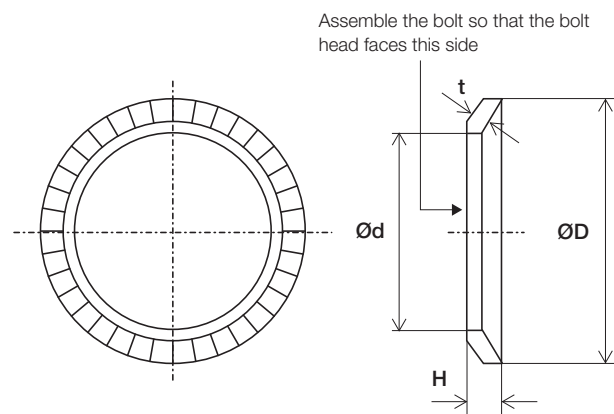

Note: When using any equivalent washer, select it with special care given to its outside diameter.

Design points

Design of actuator installation components

Align the case bolt holes (tapped holes) with the tapped holes (bolt holes) of the installation components, and the tapped holes of the shaft with the installation component bolt holes, and install the case with the designated number of bolts.

Use the specified tightening torque to uniformly tighten the hexagon socket head cap screws (with corresponding serrated lock washers).

Use either the outside or inside fit for the shaft.

After installing the actuator, we recommend the creation of a tapped hole for injecting/draining grease to enable lubricant replacement. An installation example is shown below.

Note: Always verify after installation that each bolt has been tightened at the specified torque.

• For AF017N, 042N, 080N, and 125N models

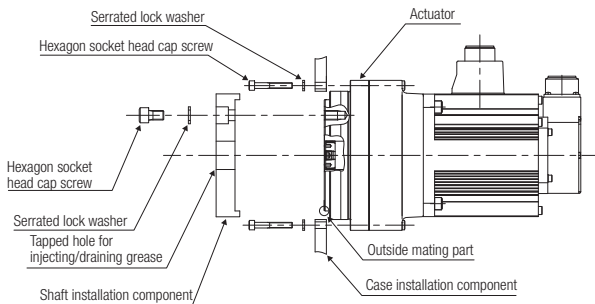

• For AF380N and 500N models

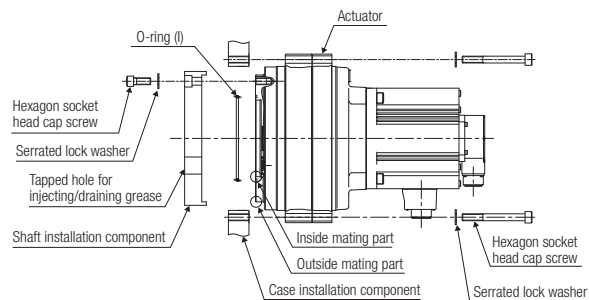

Suitable O-rings for O-Ring (l) in the diagram above are indicated in the following tables. Refer to these values when designing seals for the installation components.

• O-ring (l) JIS B 2401 : 2012 (Unit: mm)

Model	O-ring number	O-ring dimensions	
		Inside diameter	Width
AF380N	G145	Ø144.4	Ø3.1
AF500N	G185	Ø184.3	Ø5.7

If it is difficult to purchase any of the O-rings in the table to the left, select an O-ring based on the design standard of each manufacturer by referring to the dimensions listed to the left.

If an O-ring cannot be used for structural reasons, seal the part by referring to the following instructions.

• Recommended liquid sealant

Refer to the diagram at right and apply the sealant so that it does not get inside the reduction gear and does not leak out of the shaft installation bolt hole.

Name (Manufacturer)	Characteristics and applications
ThreeBond 1211 (ThreeBond Co.)	<ul style="list-style-type: none"> • Silicone-based, solventless type • Semi-dry gasket
HermeSeal SS-60F (Nihon Hermetics Co.)	<ul style="list-style-type: none"> • One-part, non-solvent elastic sealant • Metal contact side (flange surface) seal • Any product basically equivalent to ThreeBond 1211
Loctite 515 (Henkel)	<ul style="list-style-type: none"> • Anaerobic flange sealant • Metal contact side (flange surface) seal

Example application

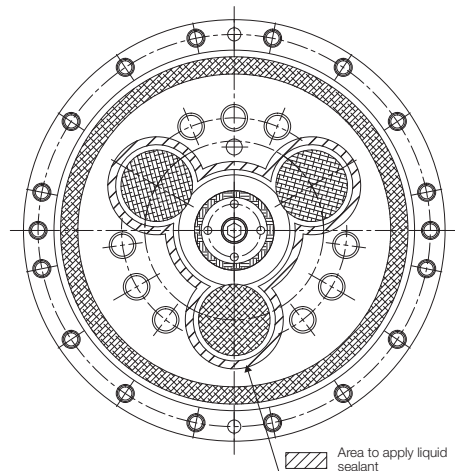

Note: 1. Do not use for copper or a copper alloy.

2. Contact us regarding use under special conditions (concentrated alkali, high-pressure steam, etc.)

Design points

Lubricant

Lubricant

The standard lubricant for the AF series is grease. The actuator is filled with our grease (RV GREASE LB00) before shipping.

When the actuator is operated with the appropriate amount of grease filled, the standard replacement time due to grease degradation is 20,000 hours. If the grease is dirty or the actuator is operated under poor ambient temperature conditions (40°C or higher), check the grease for any degradation or contamination and determine the replacement time.

<Approved grease brand>

Brand	RV GREASE LB00
Manufacturer	Nabtesco Corporation
Ambient temperature	-10 to 40°C

<Amount of lubricant>

Motor series: MINAS A6

Model	Amount of lubricant (g)
AF017N (0.4kW)	206
AF017N (1.0kW)	171
AF042N (1.0kW)	324
AF042N (1.5kW)	324
AF080N	550
AF050C	754
AF120C	955

Motor series: MINAS A5

Model	Amount of lubricant (g)
AF042N	324
AF125N	754
AF380N	1,622
AF500N	1,850
AF200C	2,626
AF320C	4,891

Note

- Keep this product away from areas with a large number of water or oil droplets. Do not let water or oil enter the connector through the wiring. If water or oil enters, it could cause damage to this product or an electric shock.
- Install the wires so that water or oil does not enter the connector. The wiring shown on the right can prevent water or oil droplets from entering the connector as they fall off the wiring.

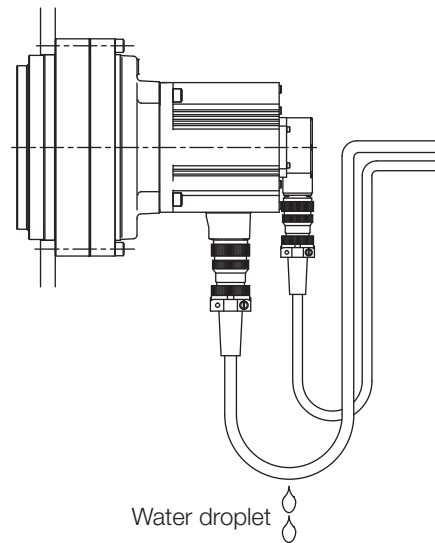

Inertia moment calculation formula

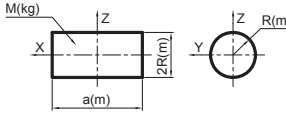
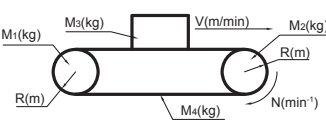
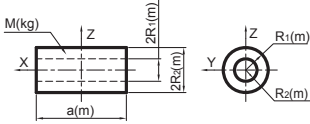
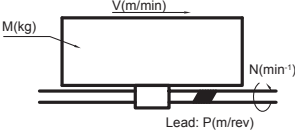
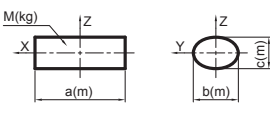
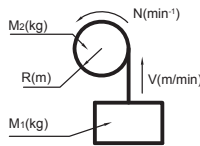
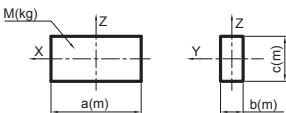
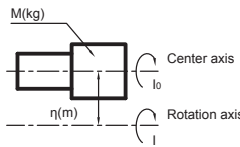
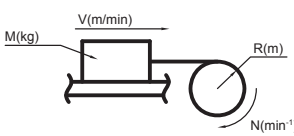
Shape	I(kg ²)	Shape	I(kg ²)
<p>1. Cylinder solid</p> 	$I_x = \frac{1}{2} M R^2$ $I_y = \frac{1}{4} M \left(R^2 + \frac{a^2}{3} \right)$ $I_z = I_y$	<p>6. Horizontal movement by conveyor</p> 	$I = \left(\frac{M_1 + M_2}{2} + M_3 + M_4 \right) \times R^2$
<p>2. Cylinder hollow</p> 	$I_x = \frac{1}{2} M (R_1^2 + R_2^2)$ $I_y = \frac{1}{4} M \left\{ (R_1^2 + R_2^2) + \frac{a^2}{3} \right\}$ $I_z = I_y$	<p>7. Horizontal movement by lead screw</p> 	$I = \frac{M}{4} \left(\frac{V}{\pi \times N} \right)^2 = \frac{M}{4} \left(\frac{P}{\pi} \right)^2$
<p>3. Oval cross section</p> 	$I_x = \frac{1}{16} M (b^2 + c^2)$ $I_y = \frac{1}{4} M \left(\frac{c^2}{4} + \frac{a^2}{3} \right)$ $I_z = \frac{1}{4} M \left(\frac{b^2}{4} + \frac{a^2}{3} \right)$	<p>8. Up/down movement by hoist</p> 	$I = M_1 R^2 + \frac{1}{2} M_2 R^2$
<p>4. Rectangle</p> 	$I_x = \frac{1}{12} M (b^2 + c^2)$ $I_y = \frac{1}{12} M (a^2 + c^2)$ $I_z = \frac{1}{12} M (a^2 + b^2)$	<p>9. Parallel axis theorem</p> 	$I = I_0 + M \eta^2$ <p>I_0 : Moment of inertia of any object about an axis through its center of mass</p> <p>I : Moment of inertia about any axis parallel to the axis through its center of mass</p> <p>η : Perpendicular distance between the above two axes</p>
<p>5. General application</p> 	$I = \frac{M}{4} \left(\frac{V}{\pi \times N} \right)^2 = M R^2$		

▶ Area In North and South America / In Europe and Africa / In Asia and others / In China
 ▶ FAX USA: / Germany: / Osaka Sales Office: / Shanghai:
 1-248-553-3070 / 49-211-364677 / 81-6-6341-7182 / 86-21-3363-2655

APPLICATION WORKSHEET

(Please supply the following items when requesting the product.)

Date: _____

Company name: _____

Department name: _____

Name: _____

E-mail: _____

Tel: - - _____

Fax: - - _____

1. How used

Name of Machine: _____

Applied to: _____

2. Model

AF

3. Conditions of load

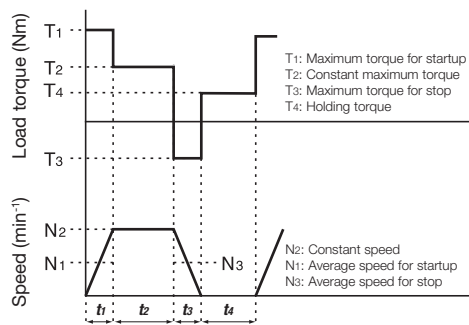

	For starting (MAX)	For constant speed	For stopping (MAX)	For holding	Cycle time
Load torque (Nm)	T1	T2	T3	T4	-
Speed (min ⁻¹)	N1	N2	N3		-
Time (s)	t1	t2	t3	t4	

Working hours Cycle/Day: Day/Year: Year

4. External load conditions

(Typical Example)

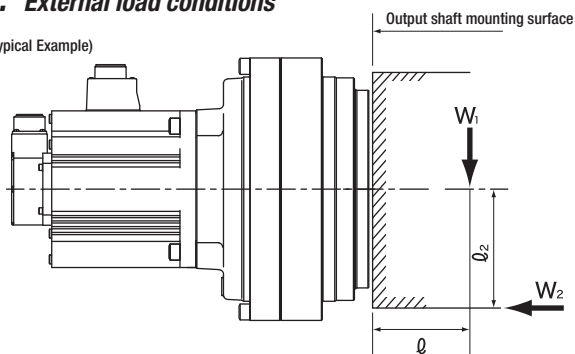

(W₁) : (N) (φ) : (mm)

(W₂) : (N) (φ₂) : (mm)

5. Operating environment

Operating environment temperature _____ °C

6. Installation

Horizontal Vertical (Upper motor Lower Motor)

Illustration for installation

7. Other

MEMO

A large grid of dashed lines for writing a memo. The grid consists of 20 columns and 30 rows of small squares, providing a structured space for notes or calculations.

Warranty

1. In the case where Nabtesco confirms that a defect of the Product was caused due to Nabtesco's design or manufacture within the Warranty Period of the Product, Nabtesco shall repair or replace such defective Product at its cost. The Warranty Period shall be from the delivery of the Product by Nabtesco or its distributor to you ("Customer") until the end of one (1) year thereafter, or the end of two thousand (2,000) hours from the initial operation of Customer's equipment incorporating the Product at end user's production line, whichever comes earlier.
 2. Unless otherwise expressly agreed between the parties in writing, the warranty obligations for the Product shall be limited to the repair or replacement set forth herein. OTHER THAN AS PROVIDED HEREIN, THERE ARE NO WARRANTIES ON THE PRODUCT, EXPRESS OR IMPLIED, INCLUDING WITHOUT LIMITATION ANY IMPLIED WARRANTY OF MERCHANTABILITY OR FITNESS FOR A PARTICULAR PURPOSE.
 3. The warranty obligation under the Section 1 above shall not apply if:
 - a) the defect was caused due to the use of the Product deviated from the Specifications or the working conditions provided by Nabtesco;
 - b) the defect was caused due to exposure to foreign substances or contamination (dirt, sand etc.)
 - c) lubricant or spare part other than the ones recommended by Nabtesco was used in the Product;
 - d) the Product was used in an unusual environment (such as high temperature, high humidity, a lot of dust, corrosive/volatile/inflammable gas, pressurized/depressurized air, under water/liquid or others except for those expressly stated in the Specifications);
 - e) the Product was disassembled, re-assembled, repaired or modified by anyone other than Nabtesco;
 - f) the defect was caused due to the equipment into which the Product was installed;
 - g) the defect was caused due to an accident such as fire, earthquake, lightning, flood or others; or
 - h) the defect was due to any cause other than the design or manufacturing of the Product.
 4. The warranty period for the repaired/replaced Product/part under the Section 1 above shall be the rest of the initial Warranty Period of the defective Product subjected to such repair/replace.
-

Nabtesco

Nabtesco Corporation

Europe and Africa

Nabtesco Precision Europe GmbH

Tiefenbroicher Weg 15, 40472 Düsseldorf, Germany
TEL: +49-211-173790 FAX: +49-211-364677
E-MAIL: info@nabtesco.de www.nabtesco.de



North and South America

Nabtesco Motion Control Inc.

23976 Freeway Park Drive, Farmington Hills, MI 48335, USA
TEL: +1-248-553-3020 FAX: +1-248-553-3070
E-MAIL: engineer@nabtescomotioncontrol.com www.nabtescomotioncontrol.com



China

Shanghai Nabtesco Motion-equipment Co., Ltd.

Room 1706, No. 388 Fu Shan Road, Pudong New Area, Shanghai 200122, China
TEL: +86-21-3363-2200 FAX: +86-21-3363-2655
E-MAIL: info@nabtesco-motion.cn www.nabtesco-motion.cn



India

Nabtesco India Private Limited

No. 506, Prestige Meridian - II No.30/8, M.G. Road, Bangalore-560 001 India
TEL: +91-80-4123-4901 FAX: +91-80-4123-4903

Asia and others

Nabtesco Corporation

Nagoya Office

9th Fl, Nagoya 2nd Saitama Bldg., 2-28 Meieki 4-chome, Nakamura-ku, Nagoya 450-0002, Japan
TEL:+81-52-582-2981 FAX:+81-52-582-2987



Customer Support Center

594 Icchoda, Katada-cho, Tsu, Mie 514-8533, Japan
TEL: +81-59-237-4672 FAX: +81-59-237-4697

E-MAIL: P_Information@nabtesco.com <https://precision.nabtesco.com/>

- Nabtesco and RV are registered trademarks or trademarks of Nabtesco Corporation.
- Panasonic and PANATERM are registered trademarks or trademarks of Panasonic Corporation.
- Specifications are subject to change without notice.
- The PDF data of this catalog can be downloaded from the following website.
<https://precision.nabtesco.com/>

If any addition or modification is made to the published information, the PDF data may be updated before the printed catalog.

Due to this, please note that some contents of the PDF data may be changed or revised from those in this catalog.

- Unauthorized reprinting, reproduction, copying, or translation of this catalog in whole or in part is strictly prohibited.
- Copyrights © 2015 Nabtesco Corporation. All rights reserved.