



80×80×38 mm

San Ace 80 9G type

General Specifications

- Material Frame: Plastic (Flammability: UL 94V-0), Impeller: Plastic (Flammability: UL 94V-0)
- Expected life See the table below. (L10 life: 90% survival rate for continuous operation in free air at 60°C, rated voltage)
Expected life at 40°C is for reference only.
- Motor protection function Locked rotor burnout protection, Reverse polarity protection
For details, please refer to p. 599.
- Dielectric strength 50/60 Hz, 500 VAC, for 1 minute (between lead wire conductors and frame)
- Insulation resistance 10 MΩ or more with a 500 VDC megger (between lead wire conductors and frame)
- Sound pressure level (SPL) At 1 m away from the air inlet
- Storage temperature -30 to +70°C (Non-condensing)
- Lead wire ⊕Red ⊖Black Sensor Yellow
- Mass 170 g

Specifications

The models listed below **have ribs and pulse sensors**. For models without ribs, append "1" to the end of model numbers.

Model no.	Rated voltage [V]	Operating voltage range [V]	Rated current [A]	Rated input [W]	Rated speed [min ⁻¹]	Max. airflow [m ³ /min] [CFM]	Max. static pressure [Pa] [inchH ₂ O]	SPL [dB (A)]	Operating temperature [°C]	Expected life [h]
9G0812K101	12	10.8 to 13.2	1.8	21.6	7800	3.1 107.3	310 1.285	58	-20 to +60	40000/60°C (70000/40°C)
9G0812G101		7 to 13.8	1.1	13.2	6300	2.55 90	211 0.847	51		
9G0812H101			0.9	10.8	5700	2.28 80	171 0.687	49		
9G0824G101	24	20.4 to 27.6	0.56	13.4	6300	2.55 90	211 0.847	51		
9G0824H101			0.42	10.1	5700	2.28 80	171 0.687	49		
9G0848G101	48	40.8 to 55.2	0.27	13.0	6300	2.55 90	211 0.847	51		
9G0848H101			0.2	9.6	5700	2.28 80	171 0.687	49		

Note: Sensor and control options are available for selection. Refer to the table on p. 626.

Airflow - Static Pressure Characteristics

9G0812K101 With pulse sensor

Operating voltage range

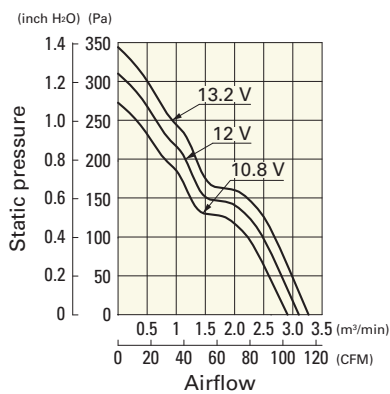

9G0812G101 With pulse sensor

Operating voltage range

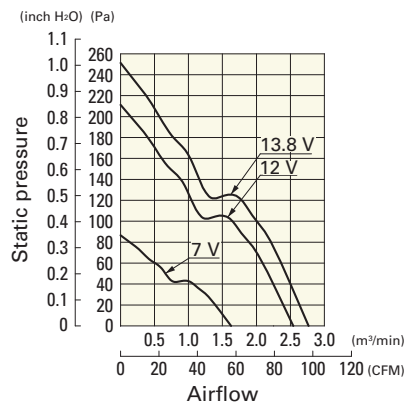

9G0812H101 With pulse sensor

Operating voltage range

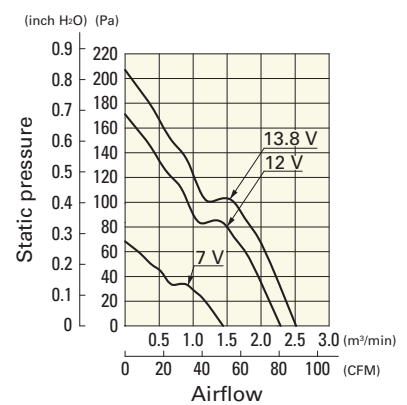

Airflow - Static Pressure Characteristics

9G0824G101 With pulse sensor

Operating voltage range

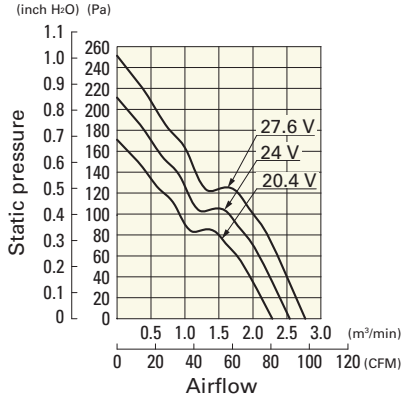

9G0824H101 With pulse sensor

Operating voltage range

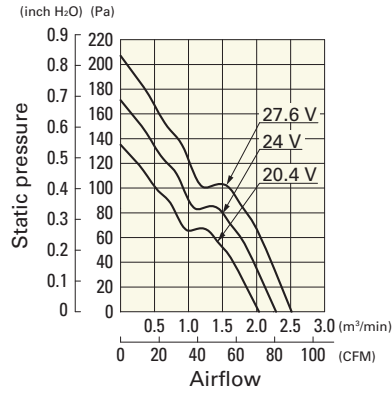

9G0848G101 With pulse sensor

Operating voltage range

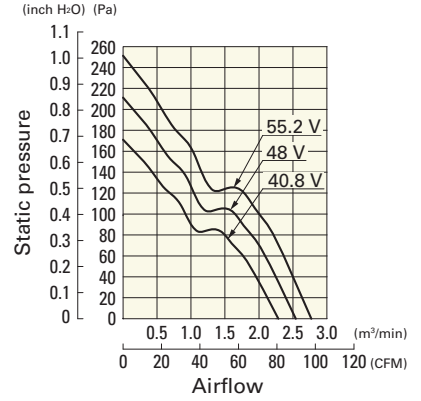

9G0848H101 With pulse sensor

Operating voltage range

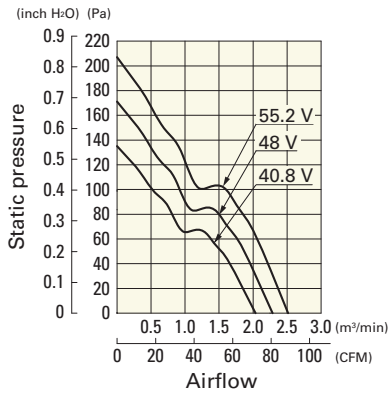

Dimensions (unit: mm) (With ribs)

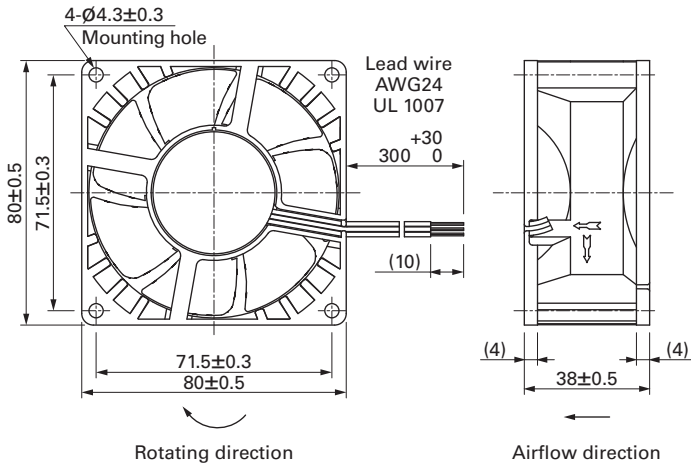

Reference Dimensions of Mounting Holes and Vent Opening (unit: mm)

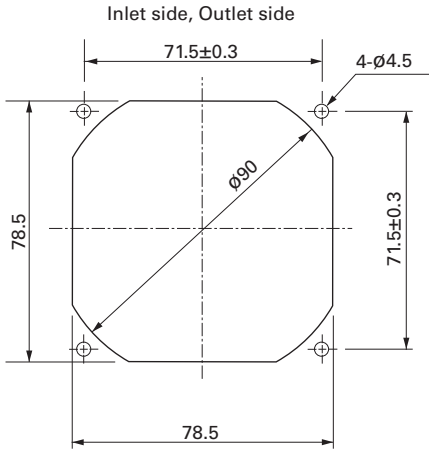

Options

Finger guards

page: p. 584

Model no.: 109-049E, 109-049H, 109-049C

Resin finger guards

page: p. 591

Model no.: 109-1002G

Resin filter kits

page: p. 592

Model no.: 109-1002F13 (13PPI), 109-1002F20 (20PPI),
109-1002F30 (30PPI), 109-1002F40 (40PPI)