

DC Fan



# 120x120x25 mm

**San Ace 120 9G type** Model 9G1212B401 is not certified.

## General Specifications

- Material ..... Frame: Plastic (Flammability: UL 94V-0), Impeller: Plastic (Flammability: UL 94V-1)
- Expected life ..... See the table below. (L10 life: 90% survival rate for continuous operation in free air at 60°C, rated voltage)  
Expected life at 40°C is for reference only.
- Motor protection function ..... Locked rotor burnout protection, Reverse polarity protection  
For details, please refer to p. 599.
- Dielectric strength ..... 50/60 Hz, 500 VAC, for 1 minute (between lead wire conductors and frame)
- Insulation resistance ..... 10 MΩ or more with a 500 VDC megger (between lead wire conductors and frame)
- Sound pressure level (SPL) ..... At 1 m away from the air inlet
- Storage temperature ..... -30 to +70°C (Non-condensing)
- Lead wire ..... ⊕Red ⊖Black or Blue  Sensor Yellow
- Mass ..... 240 g

## Specifications

The models listed below **have ribs and pulse sensors**. For models without ribs, append "1" to the end of model numbers.

Model no.	Rated voltage [V]	Operating voltage range [V]	Rated current [A]	Rated input [W]	Rated speed [min <sup>-1</sup> ]	Max. airflow [m <sup>3</sup> /min] [CFM]	Max. static pressure [Pa] [inchH <sub>2</sub> O]	SPL [dB (A)]	Operating temperature [°C]	Expected life [h]
» 9G1212G401	12	10.2 to 13.8	0.9	10.8	4100	3.68 130	120 0.482	51	-20 to +70	40000/60°C (70000/40°C)
» 9G1212E401			0.58	6.96	3650	3.25 115	98 0.394	48		
» 9G1212A401			0.4	4.8	3150	2.83 100	77 0.309	44		
» 9G1212H401		6 to 13.8	0.31	3.72	2850	2.5 88	64 0.257	40		
» 9G1212F401			7 to 13.8	0.19	2.28	2250	1.98 70	42 0.169		
» 9G1212M401		0.14		1.68	1950	1.66 59	31 0.124	29		
» 9G1212B401	10.2 to 13.8	0.06	0.72	1000	0.88 31	9.6 0.039	18			
» 9G1224G401	24	20.4 to 27.6	0.47	11.28	4100	3.68 130	120 0.482	51		
» 9G1224E401			0.37	8.88	3650	3.25 115	98 0.394	48		
» 9G1224A401			0.21	5.04	3150	2.83 100	77 0.309	44		
» 9G1224H401		12 to 27.6	0.17	4.08	2850	2.5 88	64 0.257	40		
» 9G1224F401			20.4 to 27.6	0.1	2.4	2250	1.98 70	42 0.169		
» 9G1224M401		0.08		1.92	1950	1.66 59	31 0.124	29		
» 9G1248G401	48	40.8 to 55.2	0.23	11.04	4100	3.68 130	120 0.482	51		
» 9G1248E401			0.16	7.68	3650	3.25 115	98 0.394	48		
» 9G1248A401			0.13	6.24	3150	2.83 100	77 0.309	44		
» 9G1248H401			0.1	4.8	2850	2.5 88	64 0.257	40		
» 9G1248F401			0.06	2.88	2250	1.98 70	42 0.169	35		
» 9G1248M401			0.05	2.4	1950	1.66 59	31 0.124	29		

Note 1: Sensor and control options are available for selection. Refer to the table on pp. 627 to 628.

Note 2: The » mark indicates Short LeadTime Service applicable models. See p. 654 for details.

## Airflow - Static Pressure Characteristics

**9G1212G401** With pulse sensor

Operating voltage range

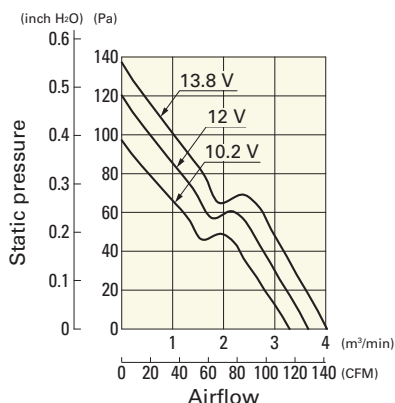

**9G1212E401** With pulse sensor

Operating voltage range

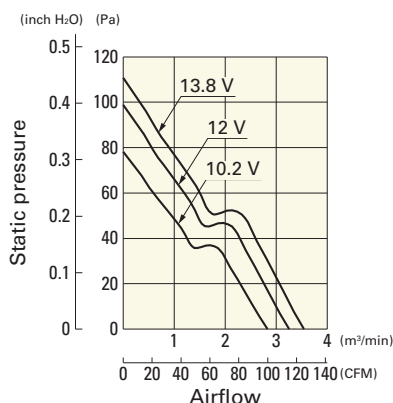

**9G1212A401** With pulse sensor

Operating voltage range

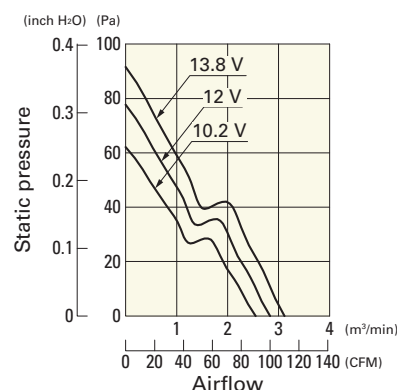

# Airflow - Static Pressure Characteristics

**9G1212H401** With pulse sensor

Operating voltage range

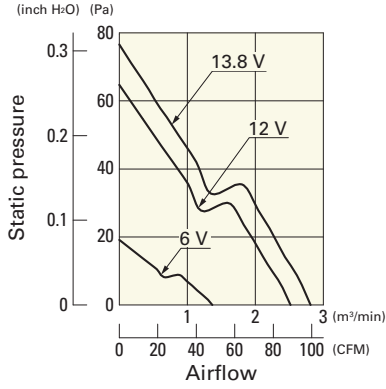

**9G1212F401** With pulse sensor

Operating voltage range

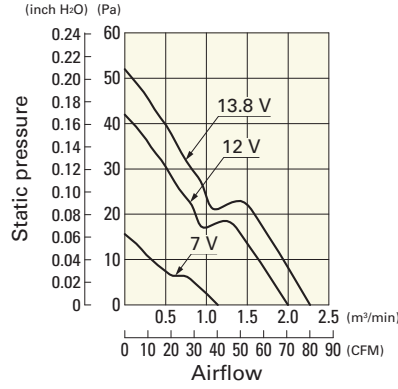

**9G1212M401** With pulse sensor

Operating voltage range

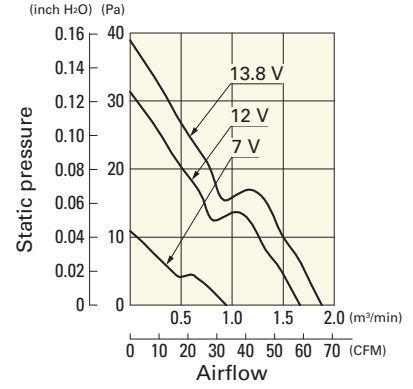

**9G1212B401** With pulse sensor

Operating voltage range

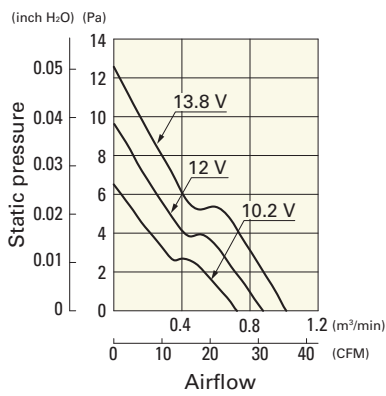

**9G1224G401** With pulse sensor

Operating voltage range

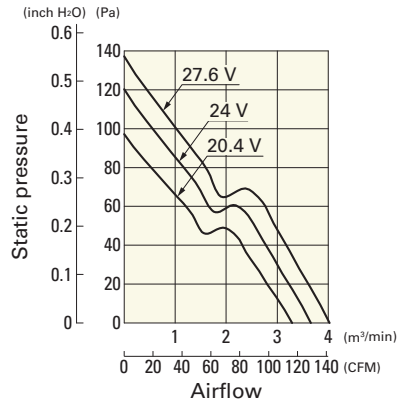

**9G1224E401** With pulse sensor

Operating voltage range

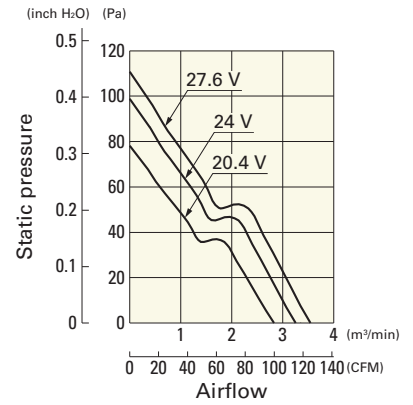

**9G1224A401** With pulse sensor

Operating voltage range

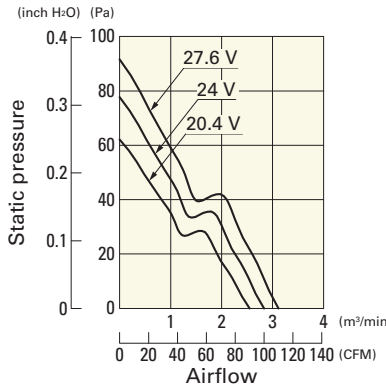

**9G1224H401** With pulse sensor

Operating voltage range

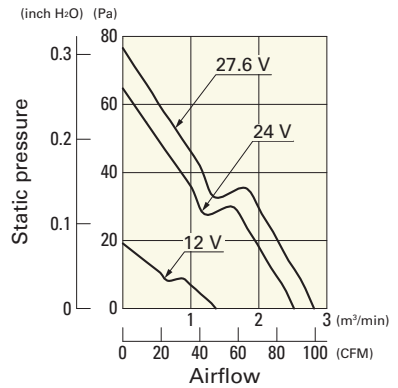

**9G1224F401** With pulse sensor

Operating voltage range

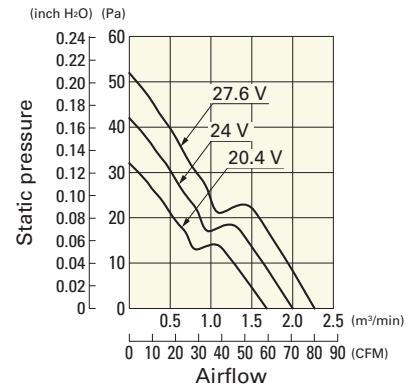

**9G1224M401** With pulse sensor

Operating voltage range

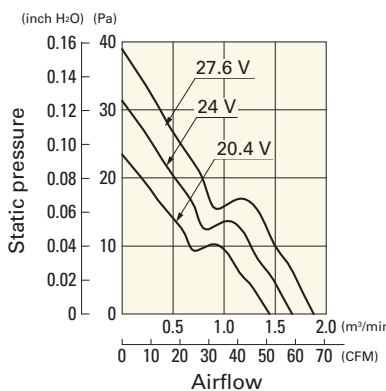

**9G1248G401** With pulse sensor

Operating voltage range

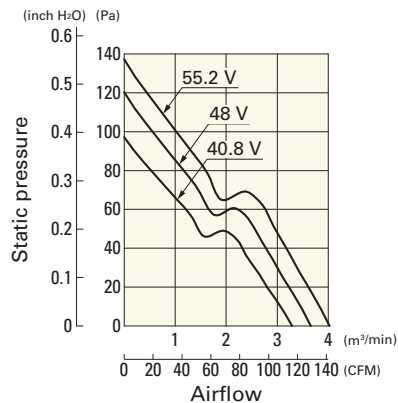

**9G1248E401** With pulse sensor

Operating voltage range

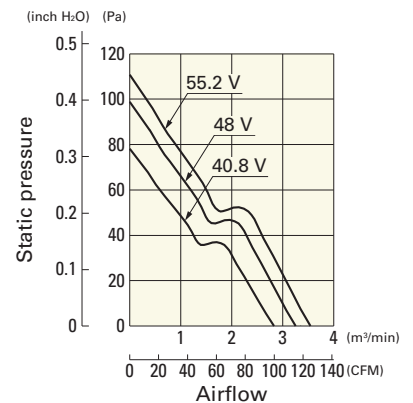

**Airflow - Static Pressure Characteristics**

**9G1248A401** With pulse sensor

Operating voltage range

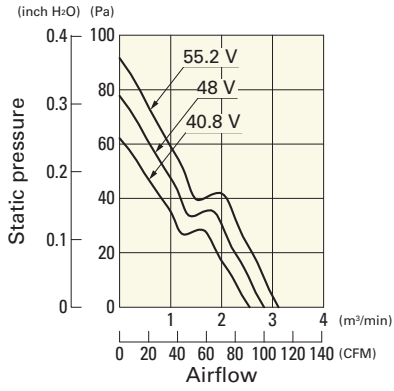

**9G1248H401** With pulse sensor

Operating voltage range

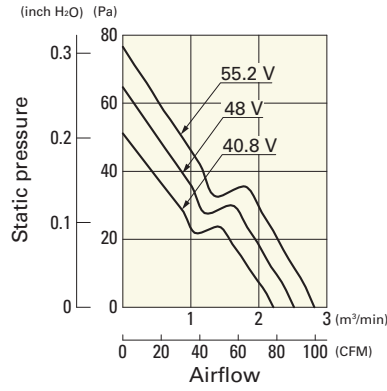

**9G1248F401** With pulse sensor

Operating voltage range

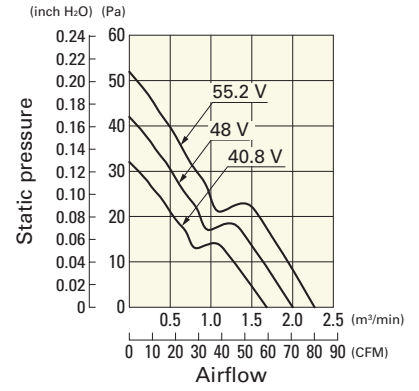

**9G1248M401** With pulse sensor

Operating voltage range

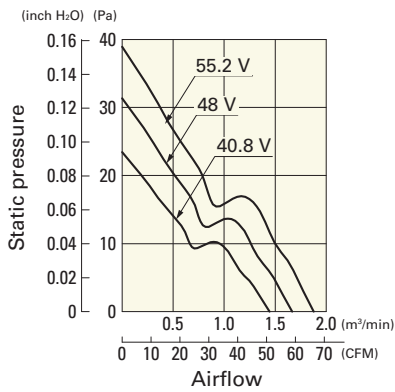

**Dimensions (unit: mm) (With ribs)**

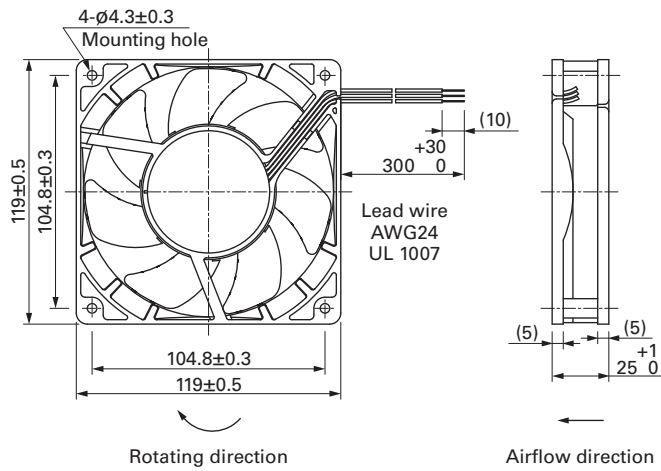

■ Reference Dimensions of Mounting Holes and Vent Opening (unit: mm)

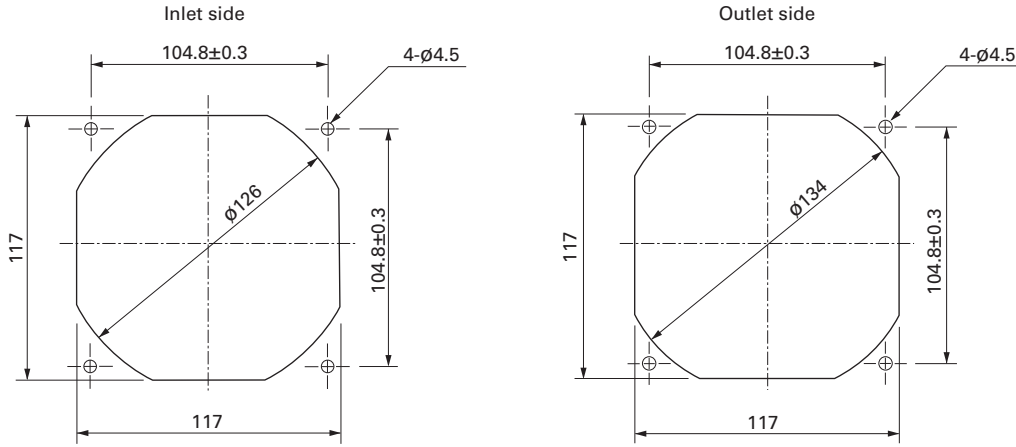

■ Options

Finger guards

page: p. 585

Model no.: 109-019E, 109-019K, 109-019C, 109-019H

Resin finger guards

page: p. 591

Model no.: 109-1000G

Resin filter kits

page: p. 592

Model no.: 109-1000F13 (13PPI), 109-1000F20 (20PPI),  
109-1000F30 (30PPI), 109-1000F40 (40PPI)