



120x120x25 mm

San Ace 120 9GV type

General Specifications

- Material Frame: Plastic (Flammability: UL 94V-0), Impeller: Plastic (Flammability: UL 94V-1)
- Expected life See the table below. (L10 life: 90% survival rate for continuous operation in free air at 60°C, rated voltage) Expected life at 40°C is for reference only.
- Motor protection function Locked rotor burnout protection, Reverse polarity protection For details, please refer to p. 580.
- Dielectric strength 50/60 Hz, 500 VAC, for 1 minute (between lead wire conductors and frame)
- Insulation resistance 10 MΩ min. at 500 VDC (between lead wire conductors and frame)
- Sound pressure level (SPL) A-weighted sound pressure level (SPL) at 1 m away from the air inlet.
- Storage temperature -30 to +70°C (Non-condensing)
- Lead wire ⊕Red ⊖Black Sensor Yellow Control Brown
- Mass 260 g

Specifications

The models listed below **have ribs and pulse sensors with PWM control function.** For models without ribs, append "1" to the end of model numbers.

| Model no. | Rated voltage [V] | Operating voltage range [V] | PWM duty cycle [%] | Rated current [A] | Rated input [W] | Rated speed [min ⁻¹] | Max. airflow [m ³ /min] [CFM] | Max. static pressure [Pa] [inchH ₂ O] | SPL [dB (A)] | Operating temperature [°C] | Expected life [h] |
|--------------|-------------------|-----------------------------|--------------------|-------------------|-----------------|----------------------------------|--|--|--------------|----------------------------|----------------------------|
| 9GV1212P4G01 | 12 | 10.2 to 13.8 | 100 | 1.68 | 20.16 | 5100 | 4.83 171 | 224 0.9 | 58 | -20 to +70 | 40000/60°C (70000/40°C) |
| | | | 0 | 0.18 | 2.16 | 1650 | 1.56 55.1 | 23.5 0.09 | 30 | | |
| 9GV1224P4G01 | 24 | 20.4 to 27.6 | 100 | 0.84 | 20.16 | 5100 | 4.83 171 | 224 0.9 | 58 | | |
| | | | 0 | 0.13 | 3.12 | 1650 | 1.56 55.1 | 23.5 0.09 | 30 | | |
| 9GV1248P4J01 | 48 | 40.8 to 55.2 | 100 | 0.5 | 24.0 | 5400 | 5.11 180 | 251 1.01 | 59 | | |
| | | | 0 | 0.15 | 7.2 | 3000 | 2.84 100 | 77.5 0.31 | 47 | | |
| 9GV1248P4G01 | 48 | 40.8 to 60.0 | 100 | 0.42 | 20.16 | 5100 | 4.83 171 | 224 0.9 | 58 | | |
| | | | 0 | 0.07 | 3.36 | 1650 | 1.56 55.1 | 23.5 0.09 | 30 | | |
| 9GV1248P4H01 | 48 | 40.8 to 60.0 | 100 | 0.33 | 15.84 | 4600 | 4.35 154 | 182 0.73 | 55 | | |
| | | | 0 | 0.07 | 3.36 | 1650 | 1.56 55.1 | 23.5 0.09 | 30 | | |

* PWM frequency is 25 kHz. Models without ratings for 0% PWM duty cycle have zero speed at 0%. When control terminal is open, speed is the same as at 100% duty cycle.

Note: Sensor and control options are available for selection. Refer to the table on pp. 611 to 612.

Airflow - Static Pressure Characteristics / PWM Duty - Speed Characteristics Example

9GV1212P4G01 With pulse sensor with PWM control function

PWM duty cycle

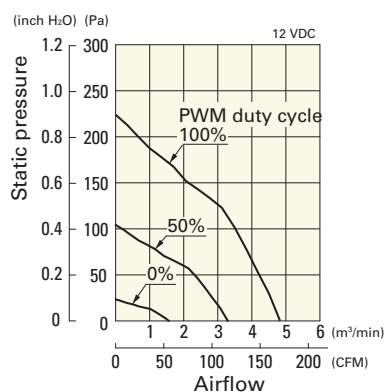

Operating voltage range

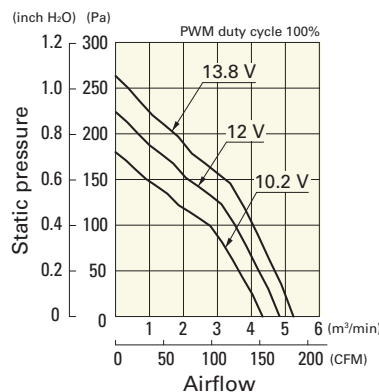

PWM duty - Speed characteristics example

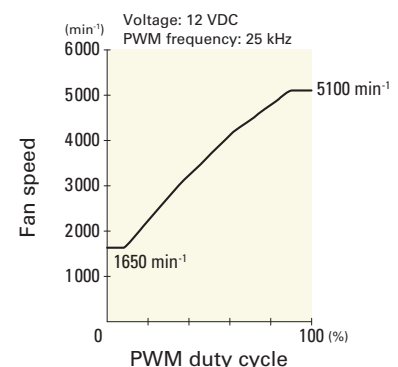

Airflow - Static Pressure Characteristics / PWM Duty - Speed Characteristics Example

9GV1224P4G01 With pulse sensor with PWM control function

PWM duty cycle

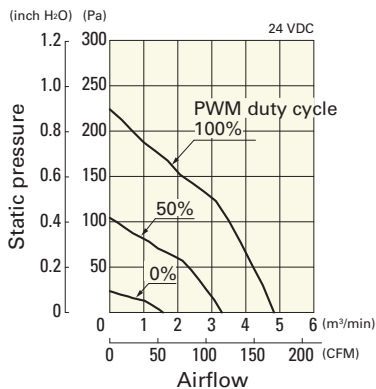

Operating voltage range

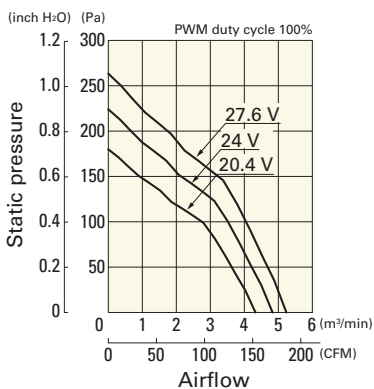

PWM duty - Speed characteristics example

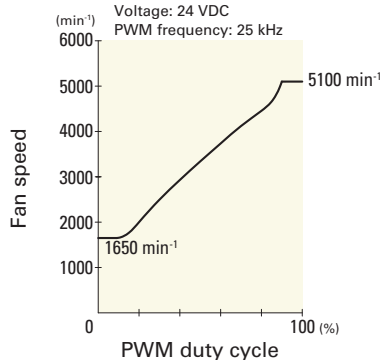

9GV1248P4J01 With pulse sensor with PWM control function

PWM duty cycle

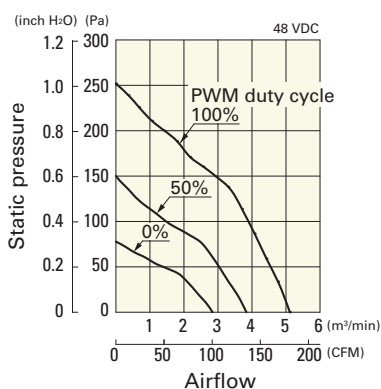

Operating voltage range

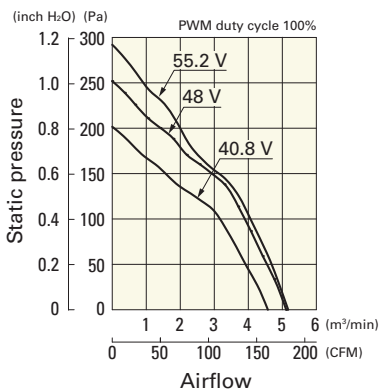

PWM duty - Speed characteristics example

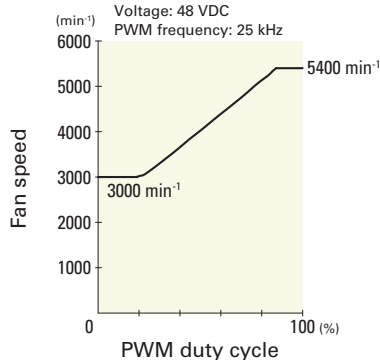

9GV1248P4G01 With pulse sensor with PWM control function

PWM duty cycle

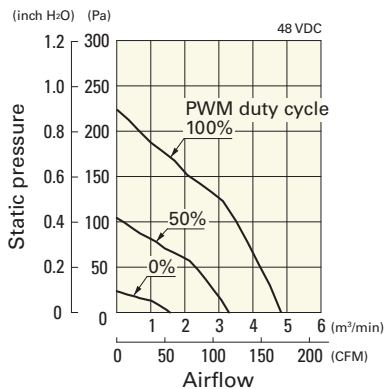

Operating voltage range

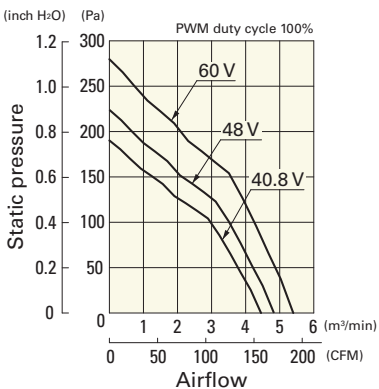

PWM duty - Speed characteristics example

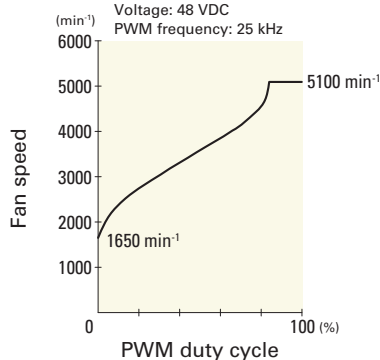

9GV1248P4H01 With pulse sensor with PWM control function

PWM duty cycle

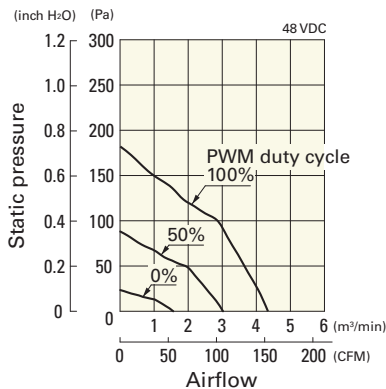

Operating voltage range

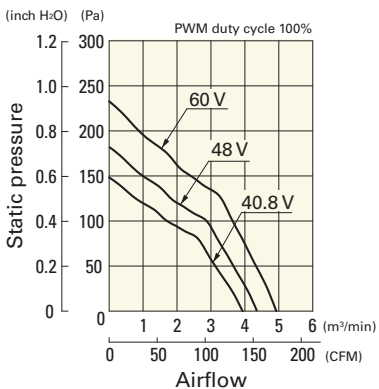

PWM duty - Speed characteristics example

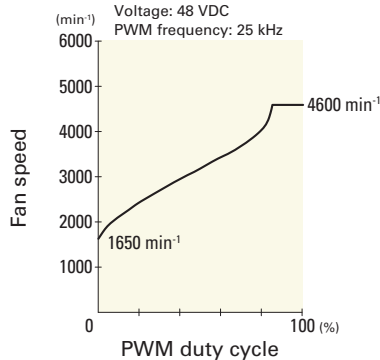

Dimensions (unit: mm) (With ribs)

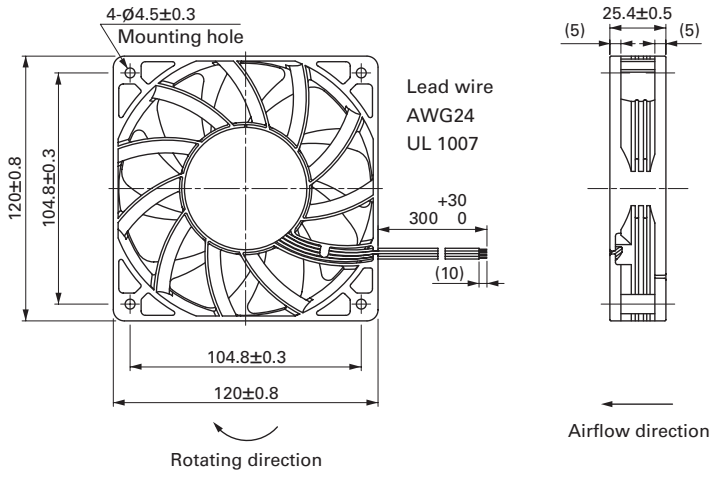

Reference Dimensions of Mounting Holes and Vent Opening (unit: mm)

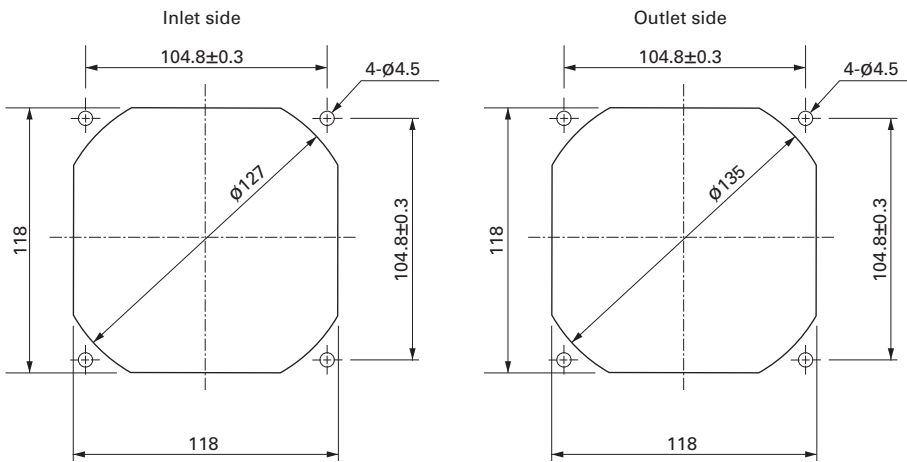

Options

Finger guards

page: p. 565

Model no.: 109-019E, 109-019K, 109-019C, 109-019H

Resin finger guards

page: p. 571

Model no.: 109-1000G

Resin filter kits

page: p. 572

Model no.: 109-1000F13 (13PPI), 109-1000F20 (20PPI),
109-1000F30 (30PPI), 109-1000F40 (40PPI)