

MA 110 series motor 220V

Technical parameters

Model	Rated power kW	Rated voltage V	Rated current Arms	Peak current Arms	Rated speed rpm	Peak speed rpm	Rated torque N-m	Peak torque N-m	Inertia ($\times 10^{-4}$ kg·m ²) (Inertia with brake)	Motor weight kg (Weight with brake)
110MAL04030	1.26	220	5.30	15.90	3000	4000	4.00	12.00	0.31 (0.33)	4.80 (6.60)
110MAL06030	1.88	220	6.60	19.80	3000	3500	6.00	18.00	0.50 (0.52)	6.70 (8.30)

Brake parameters	Brake voltage (DC) V	Brake torque N-m	Brake power W	Environmental parameters for operation	Operation temperature °C	Operation humidity	Protection rating IP
	24	≥ 8	14.4		0~+40	Relative humidity < 90% (no condensation)	IP65

Dimensions

Note: *** represents standard key.

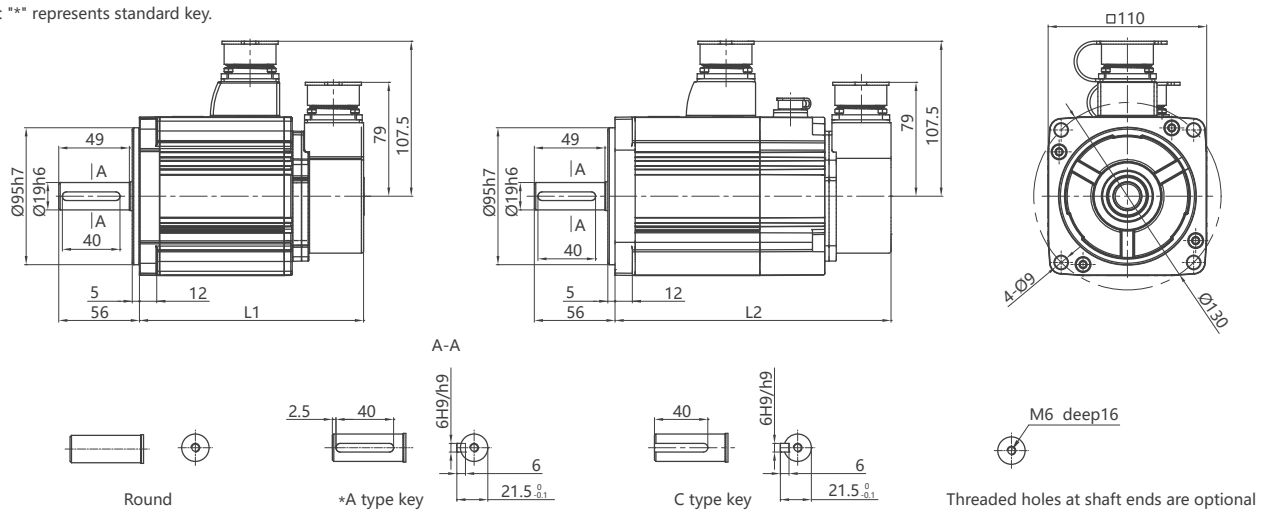

Rated torque (N-m)		4.00	6.00
L(mm)	L1	163.5	195.5
	L2	199.5	231.5

Connection definition

Brake plug H03		Power supply plug H04		Encoder plug H15			
Terminal symbol	Signal	Terminal symbol	Signal	Terminal symbol	ABS	INC	Standard INC
1	Power supply +	1	FG (SHIELD)	1	FG (SHIELD)	FG (SHIELD)	FG (SHIELD)
2	Power supply -	2	U	2	VCC	VCC	DC+5V
3	FG (SHIELD)	3	V	3	GND	GND	0V
		4	W	4	BAT+	—	A+
				5	BAT-	—	B+
				6	SD+	SD+	Z+
				7	SD-	SD-	A-
				8	—	—	B-
				9	—	—	Z-
				10	—	—	U+
				11	—	—	V+
				12	—	—	W+
				13	—	—	U-
				14	—	—	V-
				15	—	—	W-

MS/MA 130 series motor 220V

Technical parameters

Model	Rated power kW	Rated voltage V	Rated current Arms	Peak current Arms	Rated speed rpm	Peak speed rpm	Rated torque N-m	Peak torque N-m	Inertia ($\times 10^{-4}$ kg-m ²) (Inertia with brake)	Motor weight kg (Weight with brake)	
MSL series	130MSL04025	1.00	220	5.10	15.30	2500	4000	4.00	12.00	0.48 (0.58)	5.50 (8.10)
	130MSL04820	1.00	220	5.80	17.40	2000	4000	4.77	14.31	0.48 (0.58)	5.50 (8.10)
	130MSL05025	1.30	220	6.10	18.30	2500	4000	5.00	15.00	0.48 (0.58)	5.50 (8.10)
	130MSL07220	1.50	220	8.60	25.80	2000	4000	7.16	21.48	0.71 (0.74)	7.10 (9.70)
	130MSL09620	2.00	220	11.30	33.90	2000	4000	9.55	28.65	0.94 (0.97)	8.70 (11.30)
	130MSL10025	2.60	220	11.50	34.50	2500	4000	10.00	30.00	0.94 (0.97)	8.70 (11.30)
	130MSL14320	3.00	220	14.10	42.30	2000	3500	14.30	42.90	1.41 (1.44)	12.30 (14.70)
MAL series	130MAL06025	1.57	220	5.90	17.70	2500	3000	6.00	18.00	0.65 (0.68)	6.80 (9.30)
	130MAL07725	2.02	220	7.70	23.10	2500	3000	7.70	23.10	0.83 (0.86)	8.00 (10.60)
	130MAL10015	1.57	220	6.60	19.80	1500	2000	10.00	30.00	0.94 (0.97)	8.80 (11.40)
	130MAL15015	2.36	220	9.50	27.00	1500	2000	15.00	45.00	1.41 (1.44)	12.10 (14.60)

Brake parameters	Brake voltage (DC) V	Brake torque N-m	Brake power W	Environmental parameters for operation	Operation temperature °C	Operation humidity	Protection rating IP
	24	≥ 15	15		0~+40	Relative humidity < 90% (no condensation)	IP65

Dimensions

Note: "*" represents standard key.

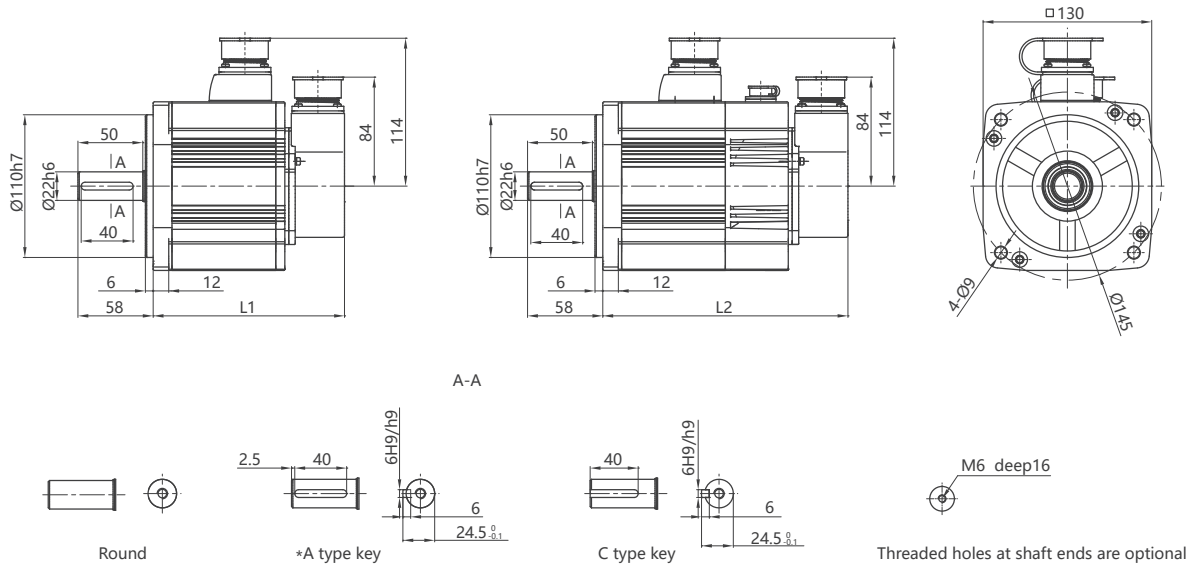

Type	MSL								MAL			
Rated torque (N-m)	4.00	4.77	5.00	7.16	9.55	10.00	14.30	6.00	7.70	10.00	15.00	
L(mm)	L1	147.5		167.5		187.5	227.5	162.5	177.5	187.5	227.5	
	L2		189.0		209.0		269.0	204.0	219.0	229.0	269.0	

Connection definition

The wiring definition of motor power cable, brake cable and encoder cable are the same as motor 110 MSL/MAL series.

MA 110/130 series motor 380V

110 MAH

Model	Rated power kW	Rated voltage V	Rated current Arms	Peak current Arms	Rated speed rpm	Peak speed rpm	Rated torque N·m	Peak torque N·m	Inertia ($\times 10^{-4} \text{kg}\cdot\text{m}^2$) (Inertia with brake)	Motor weight kg (Weight with brake)
110MAH04030	1.26	380	3.80	11.40	3000	5500	4.00	12.00	0.31 (0.33)	4.80 (6.60)
110MAH06030	1.88	380	4.20	12.60	3000	4000	6.00	18.00	0.50 (0.52)	6.70 (8.30)

Brake parameters	Brake voltage (DC) V	Brake torque N·m	Brake power W	Environmental parameters for operation	Operation temperature °C	Operation humidity	Protection rating IP
	24	≥ 8	14.4		0~+40	Relative humidity < 90% (no condensation)	IP65

130 MAH

Model	Rated power kW	Rated voltage V	Rated current Arms	Peak current Arms	Rated speed rpm	Peak speed rpm	Rated torque N·m	Peak torque N·m	Inertia ($\times 10^{-4} \text{kg}\cdot\text{m}^2$) (Inertia with brake)	Motor weight kg (Weight with brake)
130MAH04025	1.00	380	2.70	8.10	2500	4500	4.00	12.00	0.48 (0.58)	5.50 (8.10)
130MAH04820	1.00	380	3.40	10.20	2000	4500	4.77	14.31	0.48 (0.58)	5.50 (8.10)
130MAH05025	1.30	380	3.70	11.10	2500	4500	5.00	15.00	0.48 (0.58)	5.50 (8.10)
130MAH06025	1.57	380	4.10	12.30	2500	4000	6.00	18.00	0.65 (0.68)	6.80 (9.30)
130MAH07725	2.02	380	5.00	15.00	2500	4000	7.70	23.10	0.83 (0.86)	8.00 (10.60)
130MAH10015	1.57	380	4.30	12.90	1500	2500	10.00	30.00	0.94 (0.97)	8.80 (11.40)
130MAH15015	2.36	380	6.20	18.60	1500	2500	15.00	45.00	1.41 (1.44)	12.10 (14.60)

Brake parameters	Brake voltage (DC) V	Brake torque N·m	Brake power W	Environmental parameters for operation	Operation temperature °C	Operation humidity	Protection rating IP
	24	≥ 15	15		0~+40	Relative humidity < 90% (no condensation)	IP65

Note: The motor dimension and wiring definition of 380V motors are the same as 220V motors.
For details, please refer to: 110 series MSL/MAL motor (220V); 130 series MSL/MAL motor (220V).

Bending tail cover of electric coupler		
Shell number	28#	32#
Dimensions (mm)		
A	38.5	47
C	75.5	76.5
D	61.5	65.5

Notes:

- 28# is equipped on the power plug of 110 and 130 motors, and 32# on 180 motor;
- 28# is equipped on the encoder plug of 110, 130, and 180 motors;
- the dimensions of power plug (H04B) of 180 motor are slightly larger than those of 110 and 130 motors.